



Geological Database Tutorial

Copyright © 2014 Dassault Systèmes GEOVIA Inc.

All rights reserved. Dassault Systèmes GEOVIA Inc. publishes this documentation for the sole use of GEOVIA product licensees.

Without written permission, you may not sell, reproduce, store in a retrieval system, or transmit any part of this documentation. For such permission, or to obtain extra copies please contact your local GEOVIA office, or visit www.3ds.com/GEOVIA.

This software and documentation is proprietary to Dassault Systèmes GEOVIA Inc. and, except where expressly provided otherwise, does not form part of any contract. Changes may be made in products or services at any time without notice.

While every precaution has been taken in the preparation of this manual, neither the authors nor GEOVIA assumes responsibility for errors or omissions. Neither will be held liable for any damages caused or alleged to be caused from the use of the information contained herein.

Dassault Systèmes GEOVIA Inc. offers complete 3D software tools that let you create, simulate, publish, and manage your data.

GEOVIA, the GEOVIA logo, combinations thereof, and GEMS, Surpac, Minex, MineSched, Whittle, PCBC, InSite, and Hub are either trademarks or registered trademarks of Dassault Systèmes or its subsidiaries in the US and/or other countries.

Product

Surpac™ 6.6.1

Last modified: Tuesday, 1 April 2014

Table of Contents

Introduction	6
Overview	6
Requirements	6
Workflow	6
Geological database concepts	7
Collar table	7
Survey table	7
Optional tables	8
Setting up for this tutorial	10
Task: Set the work directory	10
Displaying menu bar and toolbar	11
Task: Display the menu bar and toolbar	11
Creating a DTM	12
Task: Create a DTM – graphics-based method	12
Task: Create a DTM – file-based method	14
Task: Create a DTM from spot height data	18
Task: Create a DTM using breaklines and spot heights	22
Task: Create a DTM on the plane of best-fit	24
Creating a Surpac geological database	26
Creating a new database	26
Task: Create a database	26
Connecting to an existing database	29
Task: Connect to an existing database	29
Task: Map tables from the exiting to the new database	30
To connect the database tables:	31
Connecting to a Surpac database	35
Connect to a Surpac database	35
Task: Connect to a Surpac database	35
Importing and viewing data	36
Import data	36
Task: Import data from text files	36
Viewing data	41
Task: View data in a table with constraints	41
Display drillholes	43
Task: Display drillholes	43
Task: Apply styles to drillholes	44
Manipulate drillholes	48
Task: Display cylinders	48

Task: Display lithological codes on the right-hand side	49
Task: Display assays on the left-hand side	51
Task: Display colour-filled bar graphs of gold assays on the left-hand side	52
Drillhole investigation and interrogation	54
Identify drillhole	54
Task: Run identify drillhole	54
Graphically edit drillhole	55
Task: Run edit drillhole	55
Drillhole sections	57
Creating sections graphically	57
Task: Create sections graphically	57
Advanced cross-sectional viewing	58
Task: Create viewing planes including DTMS and 3DMS	58
Viewing regular sections	62
Task: View regular sections	62
Digitising an ore outline	63
Task: Digitise an ore outline	63
Flagging an interval table	68
Task: Flag an interval table	68
Determining the grade of a digitised segment	72
Task: Determine the grade of a digitised segment	72
Section plotting	74
Creating a simple section plot	74
Task: Create a simple section plot	74
Creating a section plot with a plan strip	80
Task: Create a section plot with a plan strip	80
Creating and plotting oblique sections of drillhole data	83
Task: Create and plot an oblique section of drillhole data	83
Creating multiple section plots	92
Task: Create multiple section plots	92
Creating a title block for multiple section plots	98
Task: Create a title block for multiple section plots	98
Creating multiple section plots with title blocks	101
Task: Create multiple section plots with a title block	101
Creating and plotting a sectional fence diagram	107
Task: Create a plot using a sectional fence diagram	107
Compositing	115
Compositing by elevation	115
Task: Perform composite by elevation	115

Compositing downhole	118
Task: Perform composite downhole	118
Compositing downhole constrained by intercept table	122
Task: Perform composite downhole constrained by intercept table	122
Compositing graphical	125
Task: Perform composite graphical	125
Creating a composite report	130
Task: Create a composite report	130
Domains	131
A simple example	131
Viewing domains in Surpac	132
Task: View domains in Surpac	132
Extracting data with a domain in Surpac	134
Task: Extract data with a domain in Surpac	134
Basic Statistics	137
The Histogram	137
Bimodal Distributions	137
Outliers	138
Displaying Histograms in Surpac	138
Task: Display Histogram	138
Removing Outliers in Surpac	141
Task: Remove Outliers	141

Introduction

Overview

This document introduces the theory behind geological database processes and provides detailed examples using the geological database modelling functions in Surpac. Working through this tutorial you will gain the skills to create, use, and modify geological databases.

Requirements

Before you begin this tutorial, you must have:

- basic knowledge of Surpac
It is recommended that you understand the procedures and concepts from the Introduction tutorial.
- Surpac installed on your computer
- the data set accompanying this tutorial

Workflow

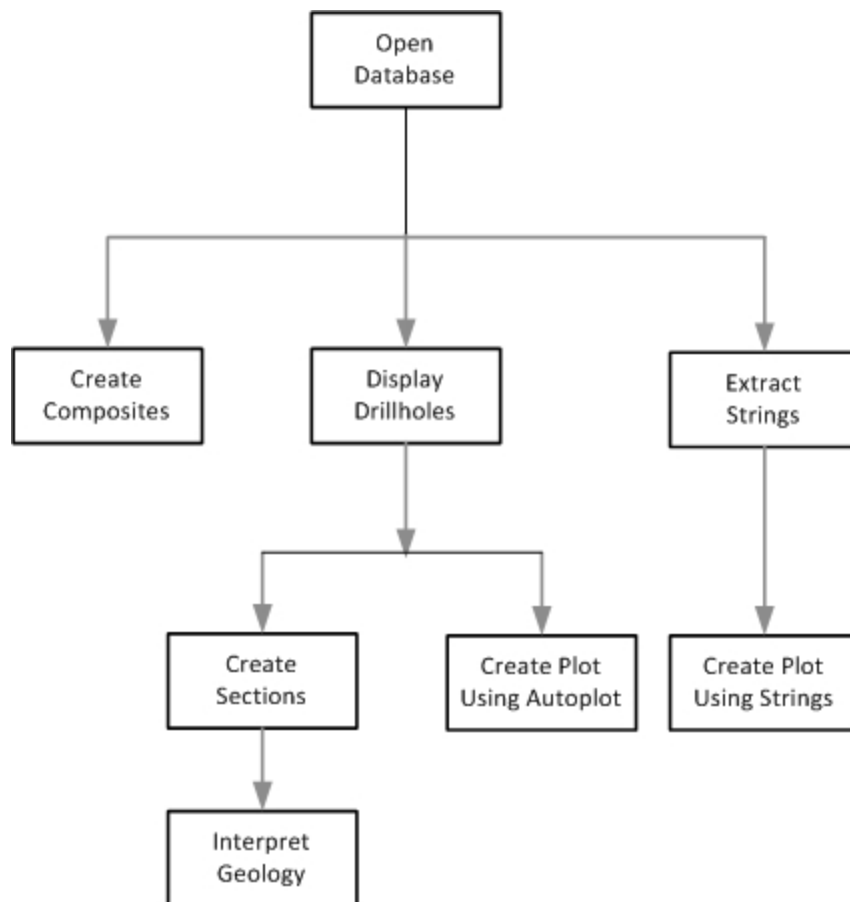

Note: This workflow demonstrates the steps in this tutorial. There are other ways to achieve a result.

Geological database concepts

You use the Geological Database module in Surpac when you are conducting feasibility studies, or want to perform estimations from drillhole data.

A geological database consists of a number of tables, each of which contains different types of data. Each table contains a number of fields. Each table also has many records, with each record containing the data fields.

Surpac uses a relational database model and supports several types of databases, including Oracle, Paradox, and Microsoft Access. Surpac also supports Open Database Connectivity (ODBC) and can connect to databases across networks. A database can contain up to 50 tables and each table can have a maximum of 60 fields.

Surpac requires two **mandatory** tables within a database: **collar** and **survey**.

Collar table

The information stored in the collar table describes the location of the drill hole collar, the maximum depth of the hole, and whether a linear or curved hole trace will be calculated when retrieving the hole. Optional collar data can also be stored for each drill hole. For example, date drilled, type of drill hole, or project name.

The mandatory fields in a collar table are shown as follows:

Mandatory Table	
	Fields
	hole_id
	y
	x
	z
	max_depth
	hole_path
	54 optional fields
COLLAR	

Survey table

The survey table stores the drill hole survey information used to calculate the drill hole trace coordinates. Mandatory fields include downhole survey depth, dip, and azimuth of the hole.

For a vertical hole that has not been surveyed, the depth would be the same as the max_depth field in the collar table, the dip would be -90, and the azimuth would be zero.

The y, x, and z fields are used to store the calculated coordinates of each survey.

Optional fields for this table can include other information taken at the survey point. For example, core orientation.

The mandatory fields in a survey table are:

Mandatory Table	
	<u>Fields</u>
SURVEY	hole_id
	depth
	y (calculated)
	x (calculated)
	z (calculated)
	dip
	azimuth
	53 optional fields

Optional tables

As well as the mandatory tables, optional tables can be added and used to store information, such as geology and assays.

There are three different types of optional tables that can be added to a database:

- Interval (depth from and depth to)
- Point (depth to)
- Discrete (point data)

Interval tables require the depth at the start of the interval (**depth_from**) and the depth at the end of the interval (**depth_to**).

Point tables require only the depth at which the sample was taken (**depth_to**). A sample identifier field is defined for interval tables but it is not a key field. This means it does not require data, the field can be left empty if there is no data available. The **y**, **x**, and **z** fields are used to store the calculated coordinates of the sample depths.

Discrete sample tables are used for storing data for a point, which has a unique **samp_id**. All that is required for this table is the **samp_id** and its position in space. That is, its **y**, **x**, and **z** coordinates. The discrete sample table is ideally suited for storing and later processing geochemical soil samples.

The following diagram is a summary of the data that can be contained in the optional tables:

OPTIONAL TABLE TYPE	
	Fields
INTERVAL ie. down hole samples	hole id samp_id depth_from y_from (calculated) x_from (calculated) z_from (calculated) depth_to y_to (calculated) x_to (calculated) z_to (calculated) 50 optional fields
POINT ie. piezometer readings	hole id depth_to y_to (calculated) x_to (calculated) z_to (calculated) 55 optional fields
DISCRETE ie. soil samples	samp_id y x z 56 optional fields

Setting up for this tutorial

A work directory is the default directory for saving Surpac files. Files used in this tutorial are stored in the folder `<shared_files>\demo_data\tutorials\geological_database`.

Where `<shared_files>` is the directory in which the Surpac shared files were installed.

In Windows 7, and Windows 8, the default path is

C: \Users\Public\GEOVIA\Surpac\66\demo_data\tutorials\geological_database.

Task: Set the work directory

1. In the Surpac Navigator, right-click the **geological_database** folder.
2. Select **Set as work directory**.

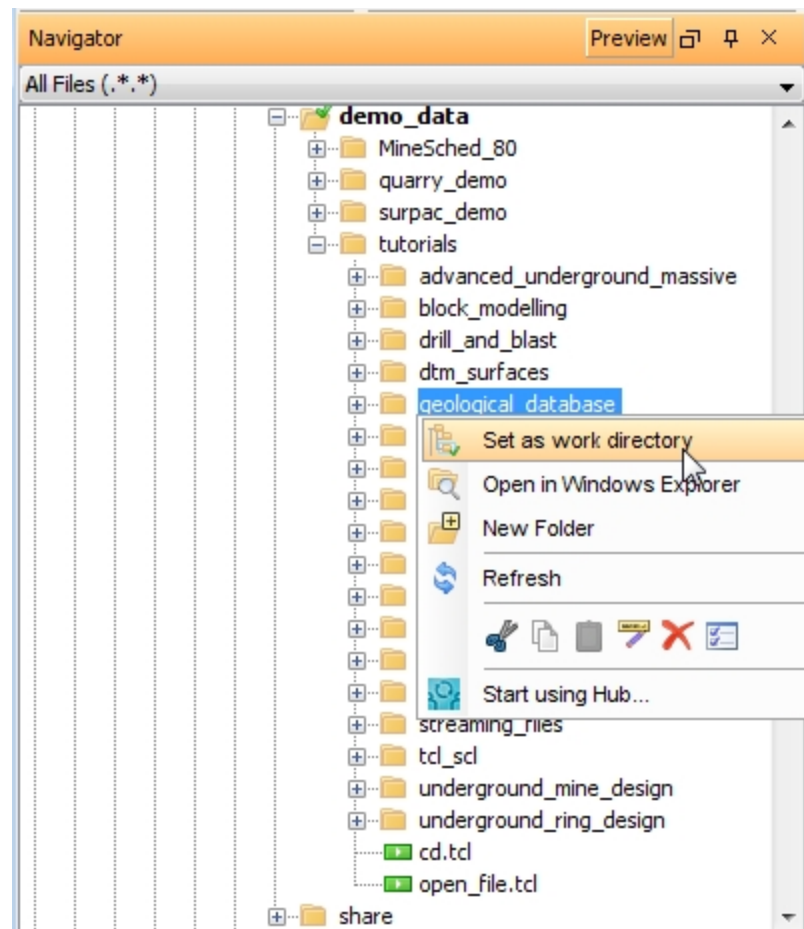

The name of the work directory is displayed in the title bar of the Surpac window.

Displaying menu bar and toolbar

Task: Display the menu bar and toolbar

When working with the geological database tools, it is helpful to use the **geology_database** profile. This displays the geological database menu bar and toolbar.

1. Right-click in the blank area next to the menus at the top of the Surpac main window.
2. From the shortcut menu, choose **Profiles > geology_database**.

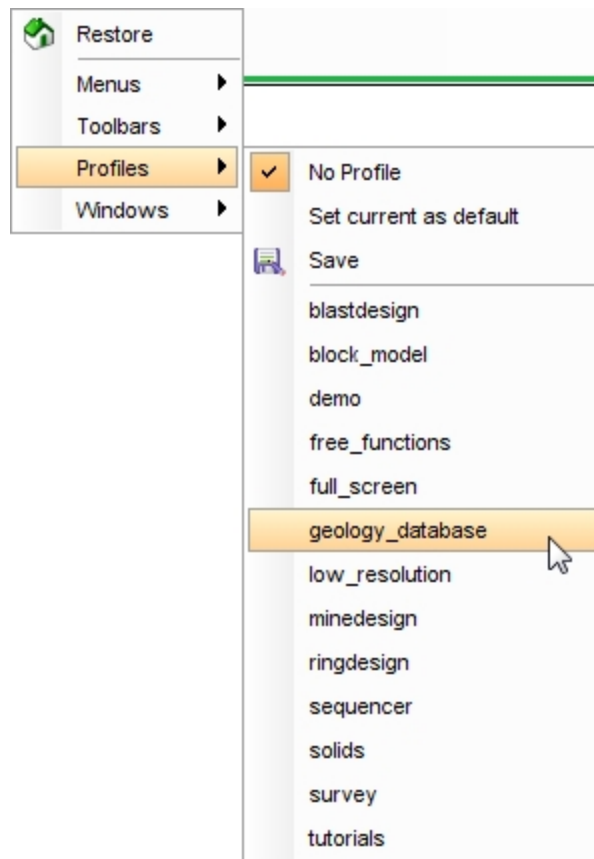

Creating a DTM

Task: Create a DTM – graphics-based method

1. Click **Reset graphics** .
2. Open **topo1.str** in **Graphics**.
topo1 is displayed.



3. Choose **Surfaces > Create DTM from layer**.
4. Enter the information as shown, and click **Apply**.

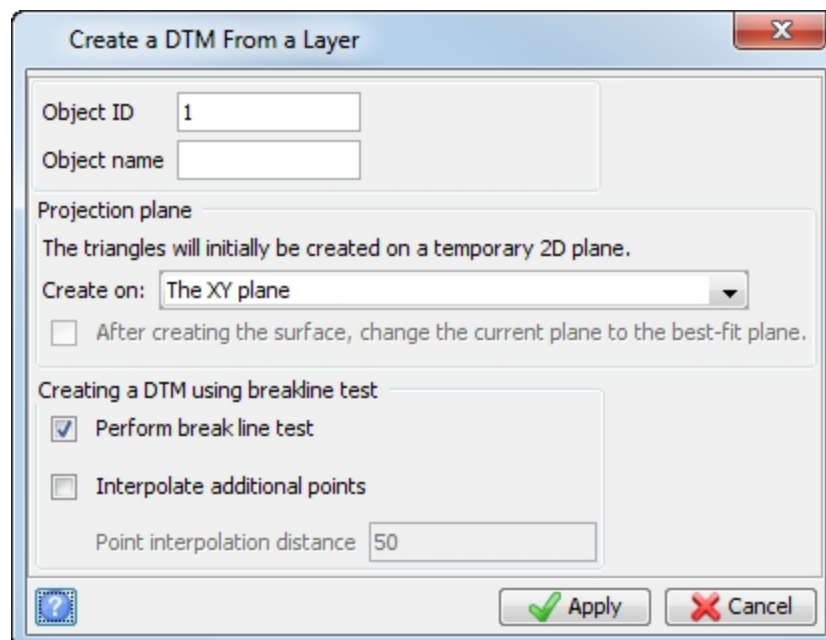

Create a DTM From a Layer

Object ID: 1

Object name:

Projection plane

The triangles will initially be created on a temporary 2D plane.

Create on: The XY plane

After creating the surface, change the current plane to the best-fit plane.

Creating a DTM using breakline test

Perform break line test

Interpolate additional points

Point interpolation distance: 50

The DTM surface is displayed.

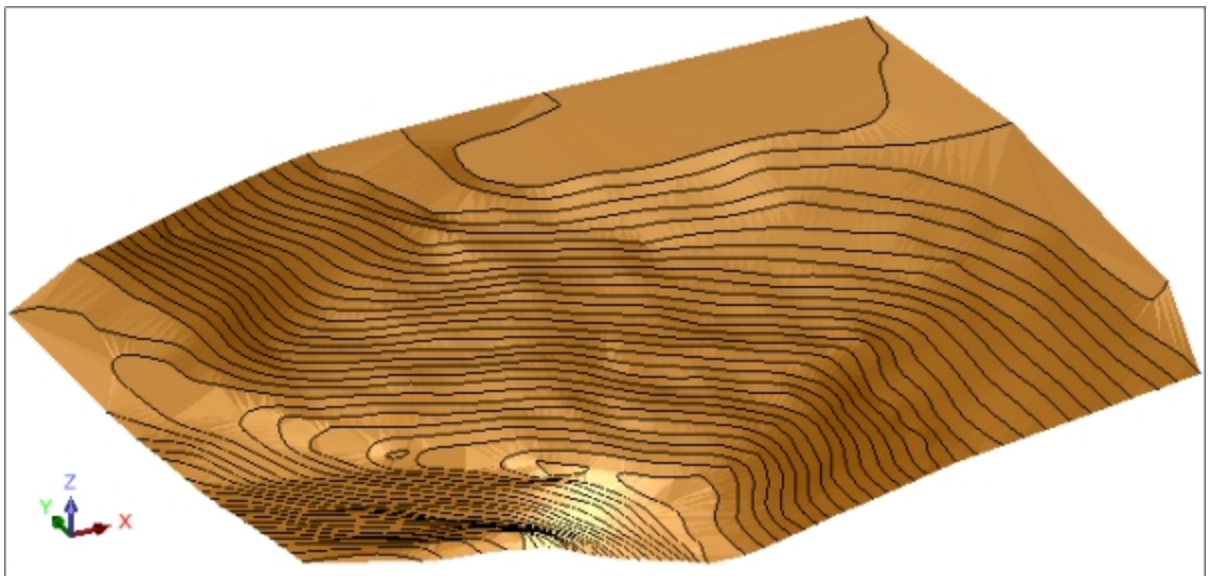

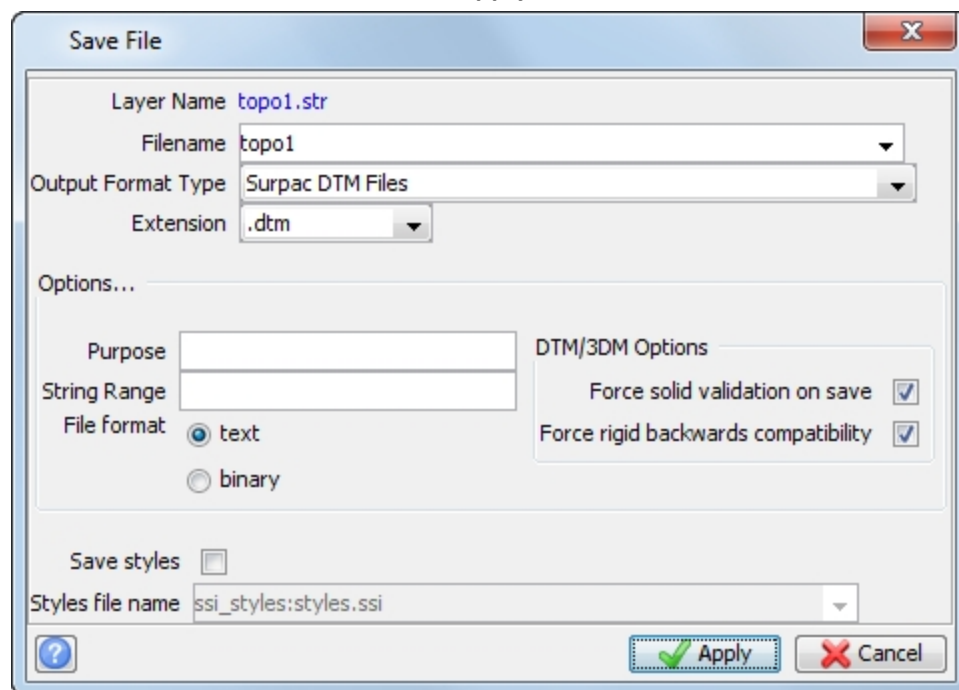

5. Choose **File > Save > String/DTM**.
6. Enter the information as shown, and click **Apply**.

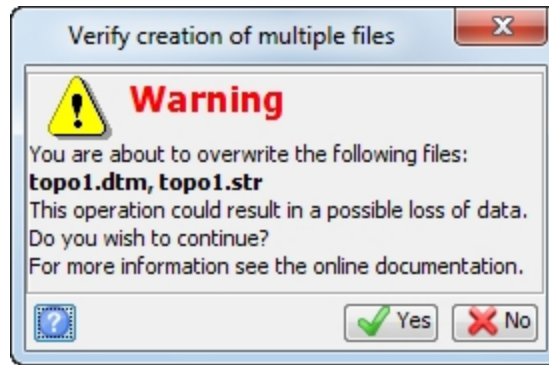

 **Note:** Because the string file exists, you are asked if you want to replace it.

7. Click **Yes**.



 **Note:** To see all of the steps performed in this task, run `_01a_create_DTM_from_layer.tcl`. You need to click **Apply** on any forms presented.

Task: Create a DTM – file-based method

In addition to demonstrating how to create a DTM using a file-based method, this task demonstrates the effect of using strings as breaklines.

1. Click **Reset graphics** .
2. Choose **Surfaces > DTM File functions > Create DTM from string file**.

3. Enter the information as shown, and click **Apply**.

Create a DTM from a string file

Define the string file

Location: pit1

Object ID: 1

Object name:

Projection plane

The triangles will initially be created on a temporary 2D plane.

Create on: The XY plane

After creating the surface, change the current plane to the best-fit plane.

Define other parameters

Common point check distance: 0.0050

Strings to act as break lines

Any spot height strings

Spot height string range:

Perform break line test

Interpolate additional points

Point interpolation distance: 50

Define the boundary string to clip the DTM

Would you like to clip the DTM to a boundary after creation?

Location:

String: 1

Retain triangles inside boundary

Retain triangles outside boundary

Apply Cancel

Note: The **Strings to act as break lines** check box is *not* selected.

DTM information is displayed in the **message window**.

Triangles formed = 3670
DTM created successfully. Details in .LOG file

The DTM report log opens in your default text editor.

```
-----  
DTM FORMATION                                01-Mar-11  
-----  
  
DTM formed from      : pit1.str  
DTM File             : pit1.dtm  
Object ID            : 1  
Number of Triangles   : 3670  
Maximum/Minimum E   : 1995.046 / 1424.116  
Maximum/Minimum N   : 7659.763 / 7036.983  
Maximum/Minimum Z   : 255.561 / 45.561  
Strings to act as breaklines : N  
Common point check distance : 0.005
```

4. Close the log file.
5. Open **pit1.dtm** in **Graphics**.

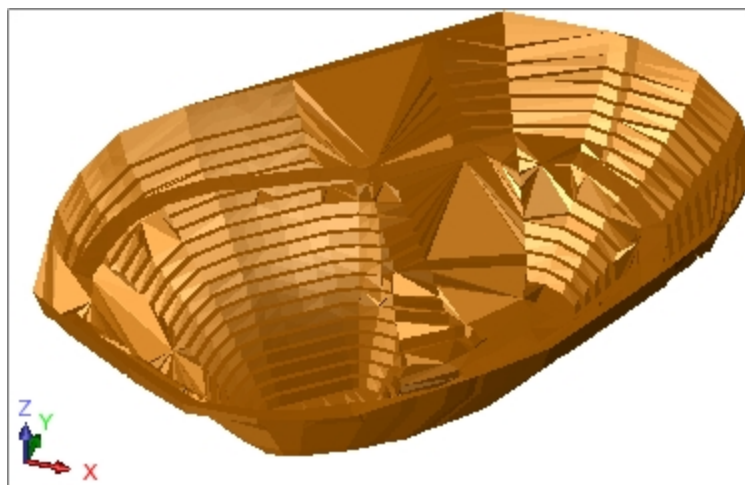

Note: There are triangles in the DTM that are created across strings. This result is *not* desired.

6. Choose **Surfaces > DTM File functions > Create DTM from string file**.

7. Enter the information as shown, and click **Apply**.

Create a DTM from a string file

Define the string file

Location: pit1

Object ID: 1

Object name:

Projection plane

The triangles will initially be created on a temporary 2D plane.

Create on: The XY plane

After creating the surface, change the current plane to the best-fit plane.

Define other parameters

Common point check distance: 0.0050

Strings to act as break lines

Any spot height strings

Spot height string range:

Perform break line test

Interpolate additional points

Point interpolation distance: 50

Define the boundary string to clip the DTM

Would you like to clip the DTM to a boundary after creation?

Location:

String: 1

Retain triangles inside boundary

Retain triangles outside boundary

Apply Cancel

Note: The **Strings to act as break lines** check box is selected.

The DTM is created and the log file opens in your default text editor.

8. Close the log file.

9. Open **pit1.dtm** in **Graphics**.

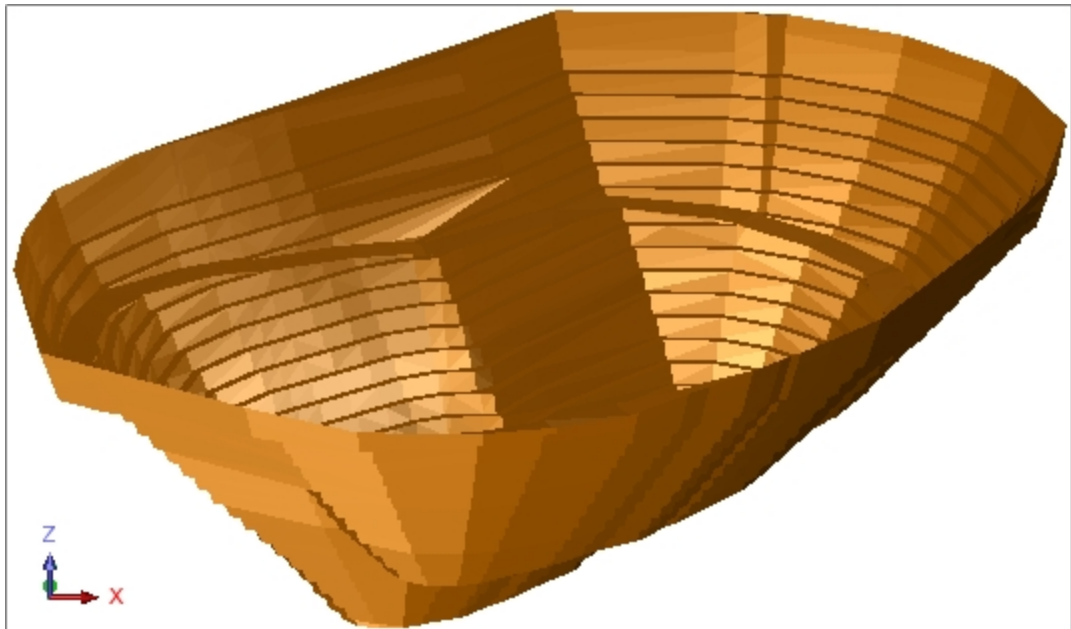

 **Note:** To see all of the steps performed in this task, run `_01b_create_DTM_from_string_file.tcl`. You need to click **Apply** on any forms presented.

Task: Create a DTM from spot height data

1. Click **Reset graphics** .
2. Open **dhc2.str** in **Graphics**.

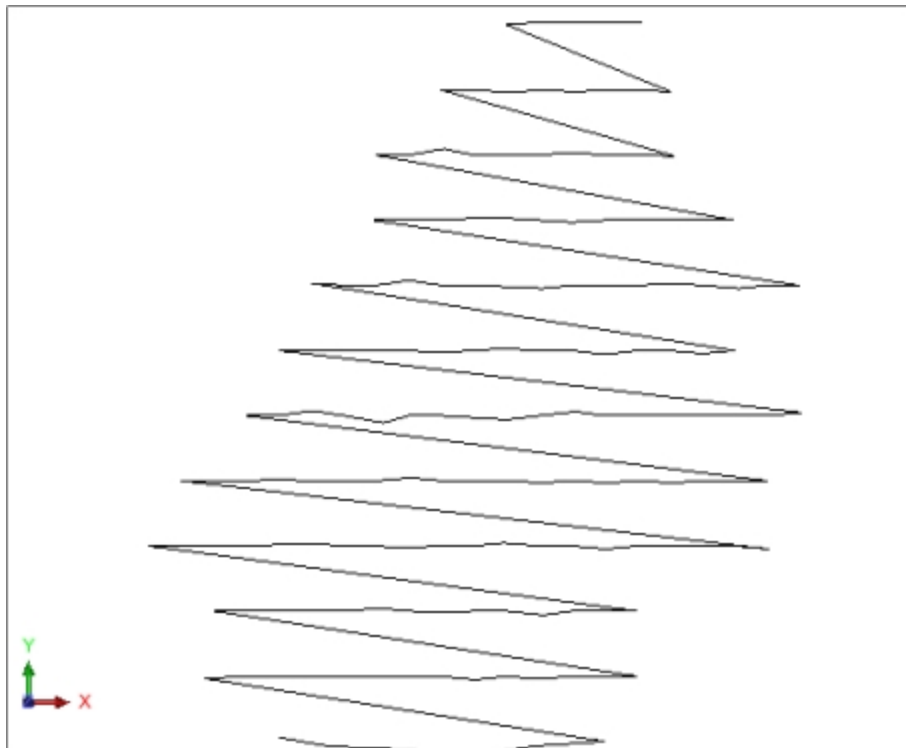

 **Note:** This file is a survey of drillhole collars before mining and can be used to model the natural surface. The file consists of one spot height string.

3. Choose **Display > Hide everything**.

4. Choose **Display > Point > Markers**.
5. Enter the information as shown, and click **Apply**.

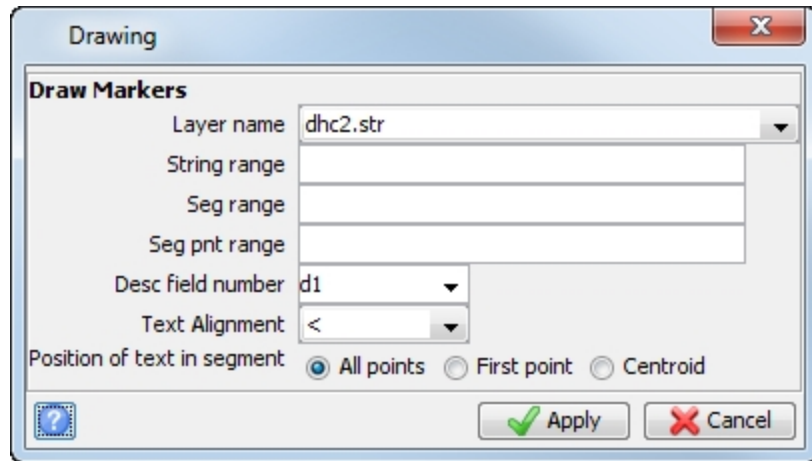

The string is displayed as markers.

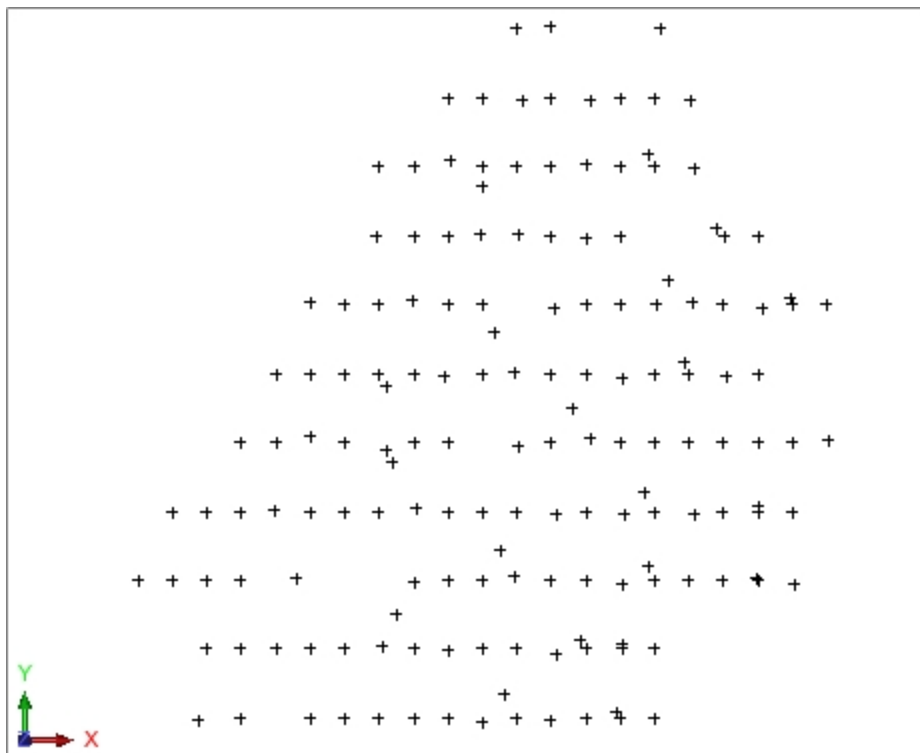

6. Choose **Surfaces > DTM File functions > Create DTM from string file**.

7. Enter the information as shown, and click **Apply**.

Create a DTM from a string file

Define the string file

Location: dhc2

Object ID: 1

Object name:

Projection plane

The triangles will initially be created on a temporary 2D plane.

Create on: The XY plane

After creating the surface, change the current plane to the best-fit plane.

Define other parameters

Common point check distance: 0.0050

Strings to act as break lines

Any spot height strings

Spot height string range:

Perform break line test

Interpolate additional points

Point interpolation distance: 50

Define the boundary string to clip the DTM

Would you like to clip the DTM to a boundary after creation?

Location:

String:

Retain triangles inside boundary

Retain triangles outside boundary

Apply Cancel

The DTM is created and the report log opens in your default text editor.

```
-----  
DTM FORMATION  
-----  
  
DTM formed from      : dhc2.str  
DTM File             : dhc2.dtm  
Object ID            : 1  
Number of Triangles  : 321  
Maximum/Minimum E   : 2732.643 / 2119.432  
Maximum/Minimum N   : 7330.425 / 6643.354  
Maximum/Minimum Z   : 1099.168 / 1045.343  
Strings to act as breaklines : N  
Common point check distance : 0.005
```

8. Close the log file.
9. Open **dhc2.dtm** in **Graphics**.
The DTM is displayed with markers.

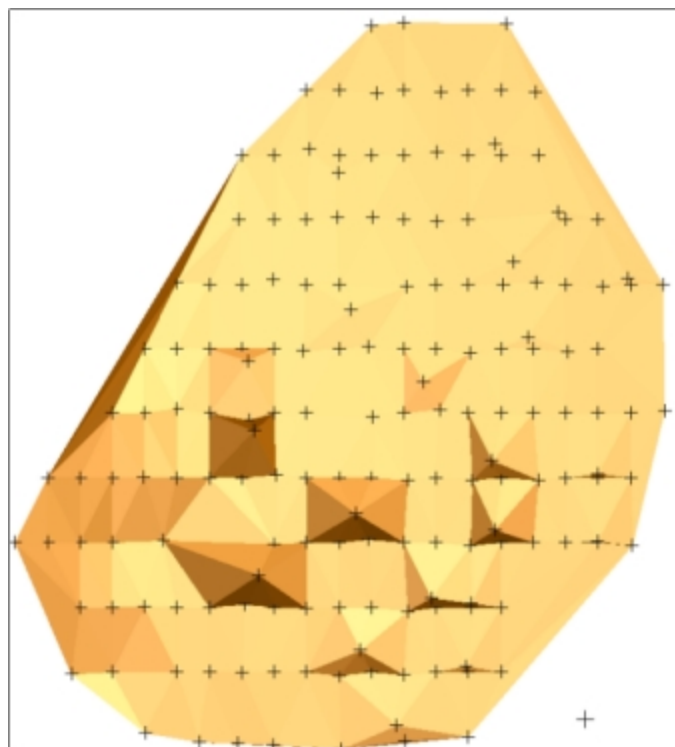

Notes:

- The default display view of a DTM is without markers.
- To see all of the steps performed in this task, run **_01c_create_dtm_from_spot_height_data.tcl**. You need to click **Apply** on any forms presented.

Task: Create a DTM using breaklines and spot heights

1. Click **Reset graphics** .
2. Open **pit2.str** in **Graphics**.
3. Choose **Display > Strings > With string numbers**.
4. Enter the information as shown, and click **Apply**.

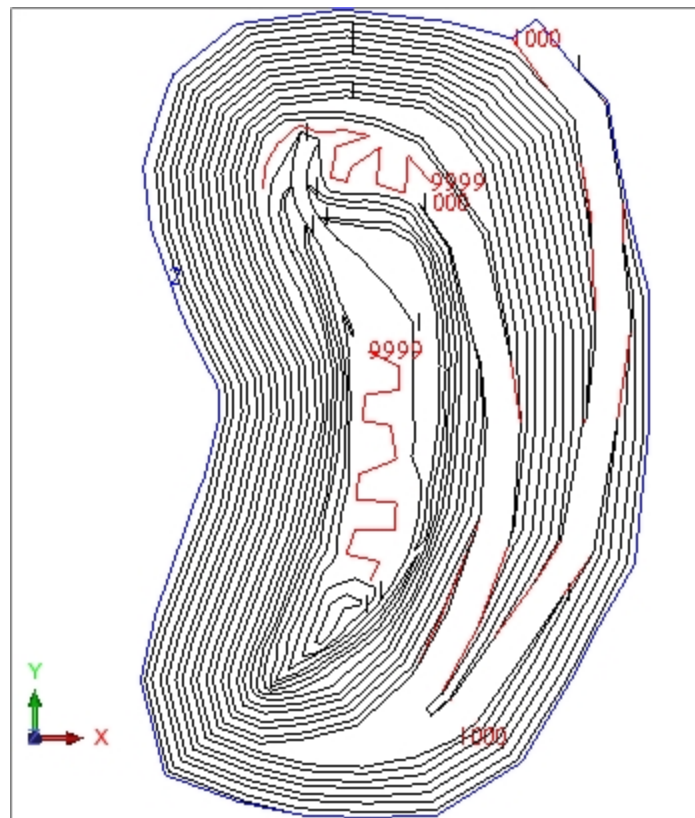
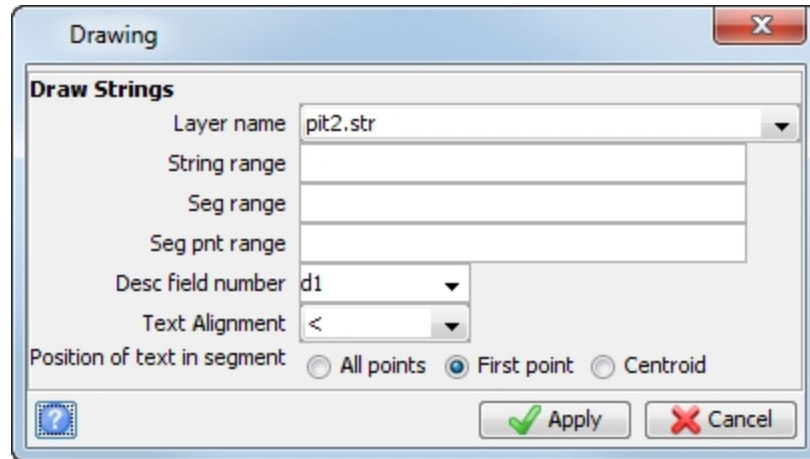

 **Note:** You can see that string 9999 is a spot height string.

5. Choose **Surfaces > DTM File functions > Create DTM from string file**.

6. Enter the information as shown, and click **Apply**.

Create a DTM from a string file

Define the string file

Location: pit2

Object ID: 1

Object name:

Projection plane

The triangles will initially be created on a temporary 2D plane.

Create on: The XY plane

After creating the surface, change the current plane to the best-fit plane.

Define other parameters

Common point check distance: 0.0050

Strings to act as break lines

Any spot height strings

Spot height string range: 9999

Perform break line test

Interpolate additional points

Point interpolation distance: 50

Define the boundary string to clip the DTM

Would you like to clip the DTM to a boundary after creation?

Location:

String:

Retain triangles inside boundary

Retain triangles outside boundary

Apply Cancel

7. Click **Reset graphics** .
8. Open **pit2.dtm** in **Graphics**.

The pit is displayed in plan view.

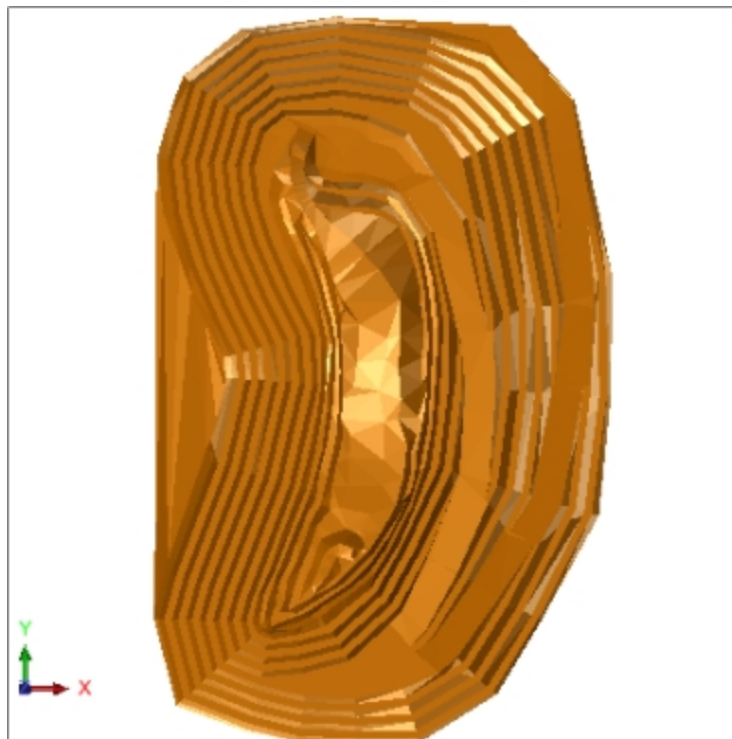

Note: To see all of the steps performed in this task, run `_01d_create_dtm_using_breaklines_and_spot_heights.tcl`. You need to click **Apply** on any forms presented.

Task: Create a DTM on the plane of best-fit

1. Click **Reset graphics**.
2. Open `topo2.str`.
3. Choose **Surfaces > Create DTM from Layer**.

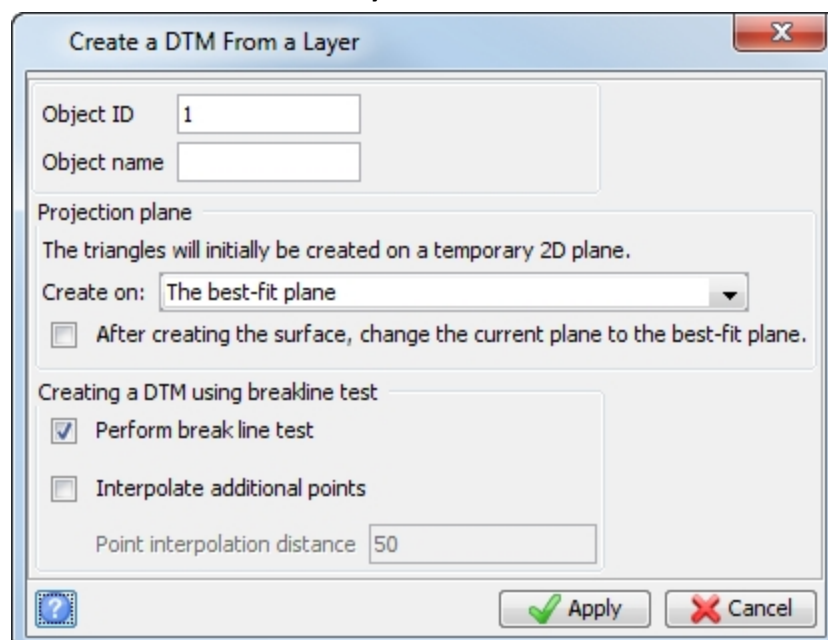

4. Enter the information as shown, and click **Apply**.
5. Click **Long section view**.

6. The DTM has been created on the best-fit plane for the data.

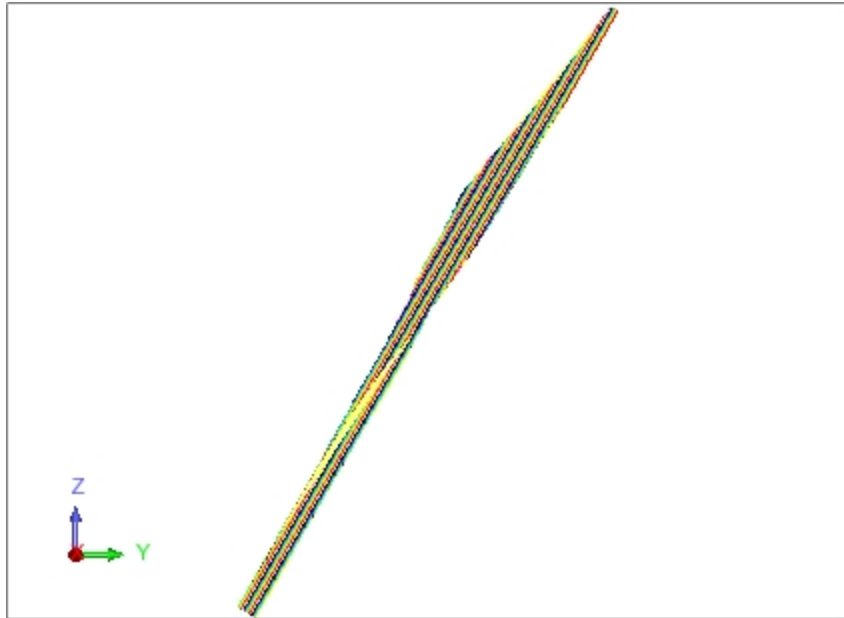

Creating a Surpac geological database

Creating a new database

Task: Create a database

1. Choose **Database > Open/New**.
2. Enter the information as shown, and click **Apply**.

The *Create definition for new database* form appears, showing the name and location of the new database.

3. Click **Apply**.
4. Enter the information as shown, and click **Apply**.

An empty database with only mandatory fields in the tables Collar, Survey, and Translation is created. You can also create optional tables for sample and geology data.

5. Enter the information as shown, and click **Apply**.

Define the optional tables for the database			
	Table name	Table type	Time dependent
1	assay	interval	<input type="checkbox"/>
2	geology	interval	<input type="checkbox"/>

Note: To create a new row, right-click the row number, and click **Add**.

6. Click the **assay** tab, and enter the information as shown.

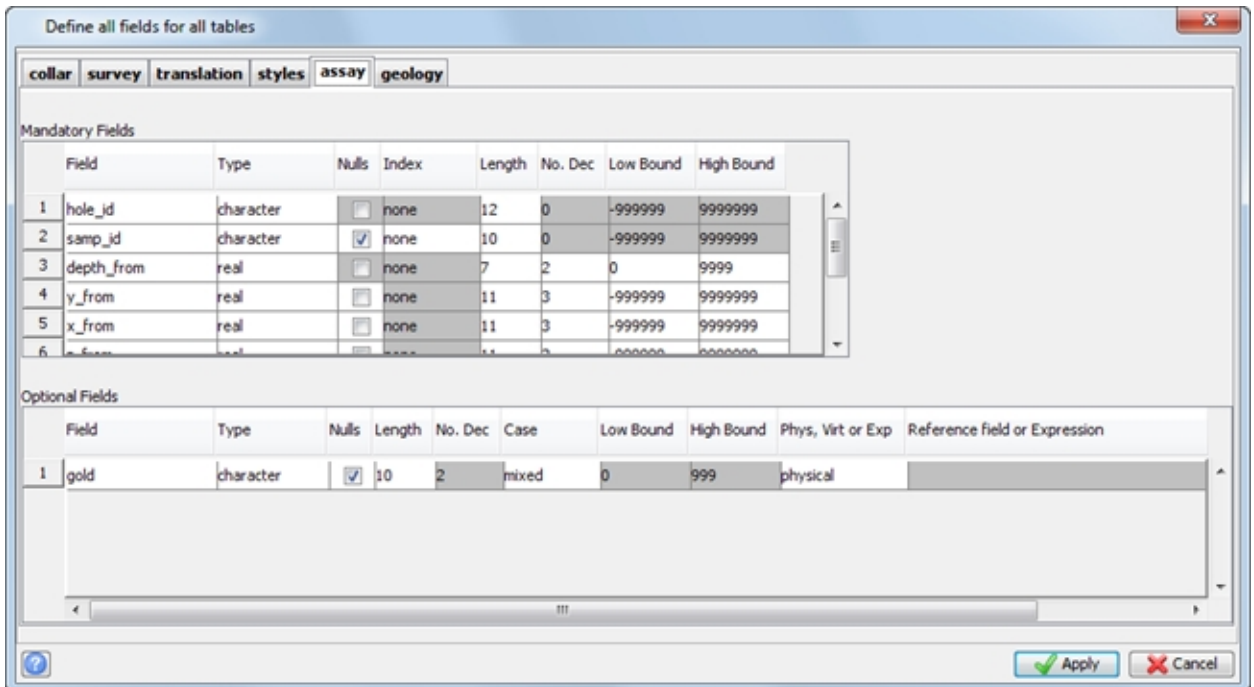

7. Click the **geology** tab, enter the information as shown, and then click **Apply**.

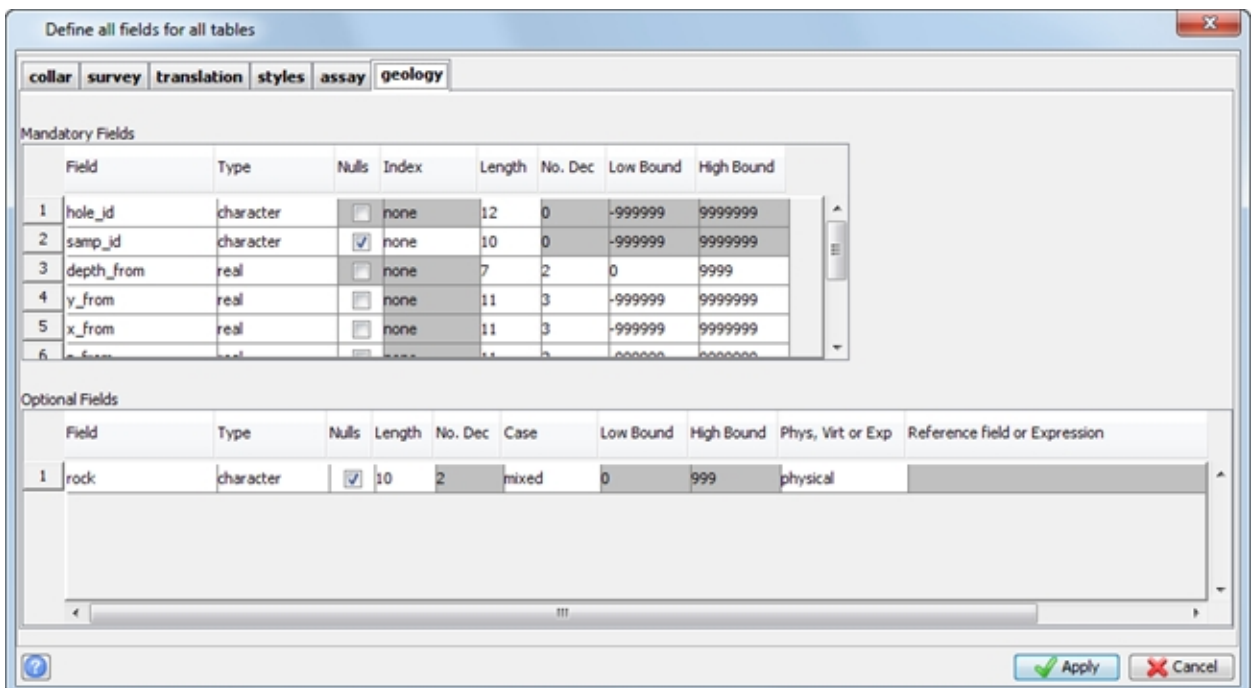

The database is created. The database name appears on the status bar to indicate that you are connected to it.

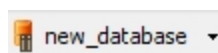

Two files have been created:

- **new_database.accdb** The Microsoft Access database which contains the data.

- **new_database.ddb** The file that Surpac requires to connect to the database.
8. Choose **Database > Close**.
 9. In the Navigator, right-click **new_database.ddb**, and select **Edit**.
The file is opened in your default text editor.

```

DATABASE "new_database"
TYPE "access"
DB_SPECIFIC "directory=c:/users/public/geovia/surpac/66/demo_data/tutorials/geological_database"
TABLE collar
  FIELD hole_id
    TYPE character( 12)
    VALIDATION "SSI_edit_style=upper~SSI_length=12"
  FIELD y
    TYPE real( 11, 3)
    VALIDATION "SSI_edit_style=r8~SSI_bounds=-999999 9999999~SSI_decimals=3~SSI_length=11"
  FIELD x
    TYPE real( 11, 3)
    VALIDATION "SSI_edit_style=r8~SSI_bounds=-999999 9999999~SSI_decimals=3~SSI_length=11"
  FIELD z
    TYPE real( 11, 3)
    VALIDATION "SSI_edit_style=r8~SSI_bounds=-999999 9999999~SSI_decimals=3~SSI_length=11"
  FIELD max_depth
    TYPE real( 11, 3)
    VALIDATION "SSI_edit_style=r8~SSI_bounds=0 9999~SSI_decimals=3~SSI_length=11"
  FIELD hole_path
    TYPE character( 8)
    VALIDATION "SSI_edit_style=mixed~SSI_set=;LINEAR;CURVED;VERTICAL;linear;curved;vertical~SSI_length=8"
  NULLS
  INDEX idx1 UNIQUE
  ASC hole_id
TABLE survey
  FIELD hole_id

```

 **Note:** The value for DB_SPECIFIC can be any folder on your local drive or on a network drive.

The database definition file (**.ddb**) contains:

- the type and name of database
- where the database is located (that is, a path location)
- table names, field names, and formatting of each field type

The **.ddb** file is a text file and contains no data. It allows Surpac to connect to a relational database and usually has the same name as the database.

10. Close the text editor.

 **Note:** To see all of the steps in this task, run **01_create_new_database.tcl** . You need to **Apply** any forms presented.

Connecting to an existing database

You can connect to an existing database that was not created in Surpac. This process is called **mapping a database**.

The DB MAPPER function creates links between tables and fields in the existing database and the database structure in Surpac. This function also allows you to define a view of your database by specifying which tables and fields you want to use in Surpac. This is useful if you have a very large database and you only need to use information from a few tables.

Task: Connect to an existing database

1. Choose **Database > Map the database**.
2. Enter the information as shown, and click **Next**.

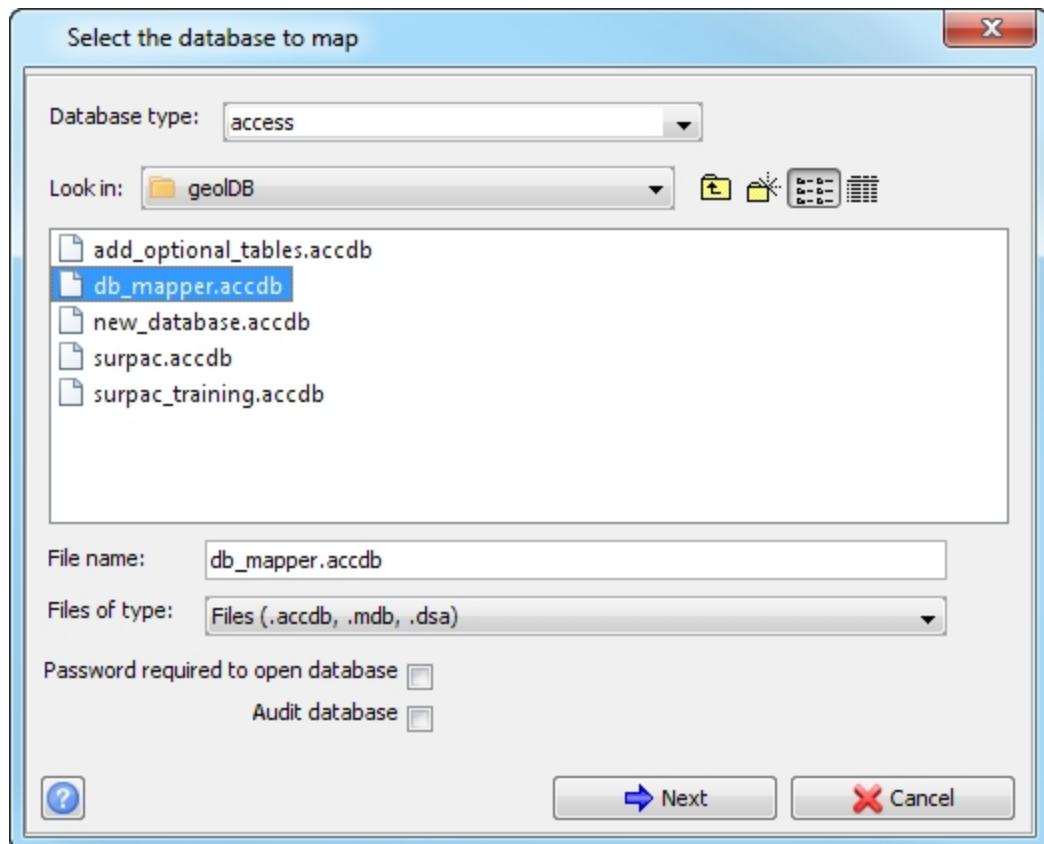

3. Enter the information as shown, and click **Next**.

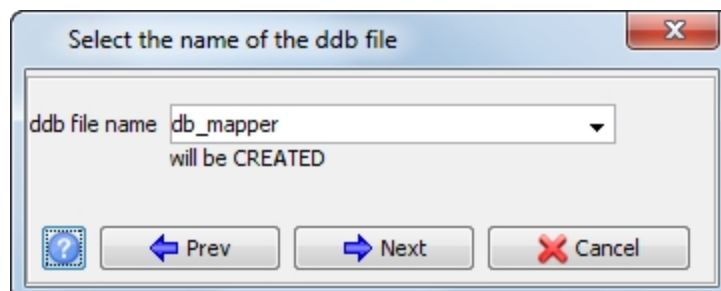

A progress bar appears.

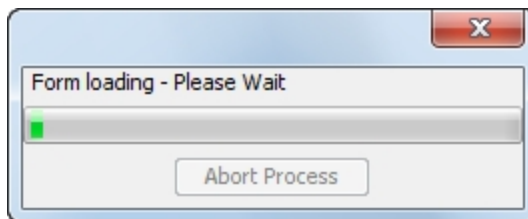

The **Map the database** form is displayed.

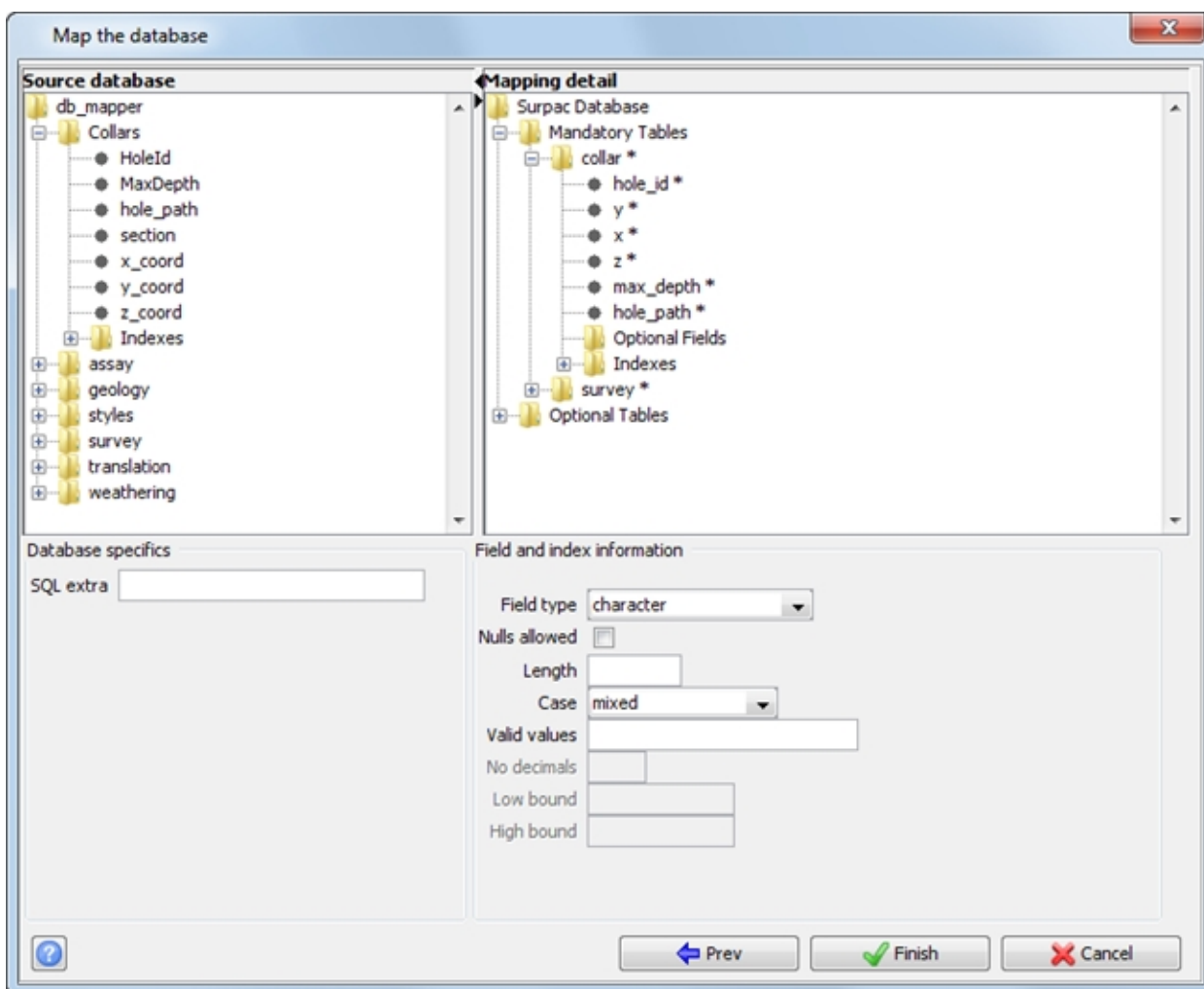

Task: Map tables from the exiting to the new database

The *Map the database* form is split into two sections. The left-hand side, the **Source database**, shows all tables and queries contained in the database. The right-hand side, the **Mapping detail**, shows the tables and field names required for connecting Surpac to your database.

The mapping detail pane on the right-hand side of the form shows two folders labelled **Mandatory Tables** and **Optional Tables**.

Under the **Optional Tables** folder there are five folders.

The first folder represents the **translation** table that is required for translating numeric codes, such as below detection assays from the lab. This folder contains the mandatory fields for the translation table and folders for any optional fields and indexes.

The **styles** table stores the drawing styles created for drillhole geology codes and assay values that are stored in the database. When connecting to an existing database, you need to create the styles before you can display coloured values for the drillholes.

The **Interval Tables**, **Point Tables**, and **Discrete Tables** folders are used to specify which optional tables you want to include in your database.

If the existing database uses the same table names and field name conventions as a database created using Surpac, then the collar, survey, interval, and point tables are mapped automatically.

 **Note:** These items are case-sensitive.

If other naming conventions have been used, including upper or mixed case, then each table **must** be mapped. Table names or field names that have not been recognised by running the DB MAPPER function are highlighted with an asterisk (*).

 **Note:** Table names or fields names that have an asterisk (*) next to their name must be mapped.

To connect the database tables:

1. Click the + to expand the **survey** and **collar** folders.
2. Expand the **Options Tables** folder.

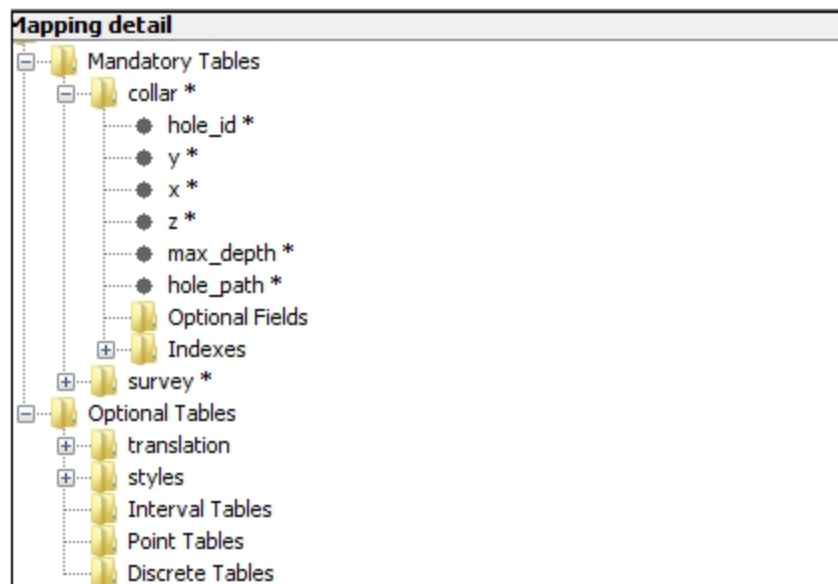

3. Map the collar and survey tables:
 - a. Drag and drop the **Collars** table from the left-hand side to the top of the **collar** table on the right-hand side.
 - b. Drag and drop the **HoleId** field from the left-hand side to the top of the **hole_id** field on the right-hand side.
 - c. Drag and drop the **MaxDepth** field from the left-hand side to the top of the **max_depth** field on the right-hand side.
 - d. Repeat this process to map each of the remaining mandatory fields (y, x, and z).

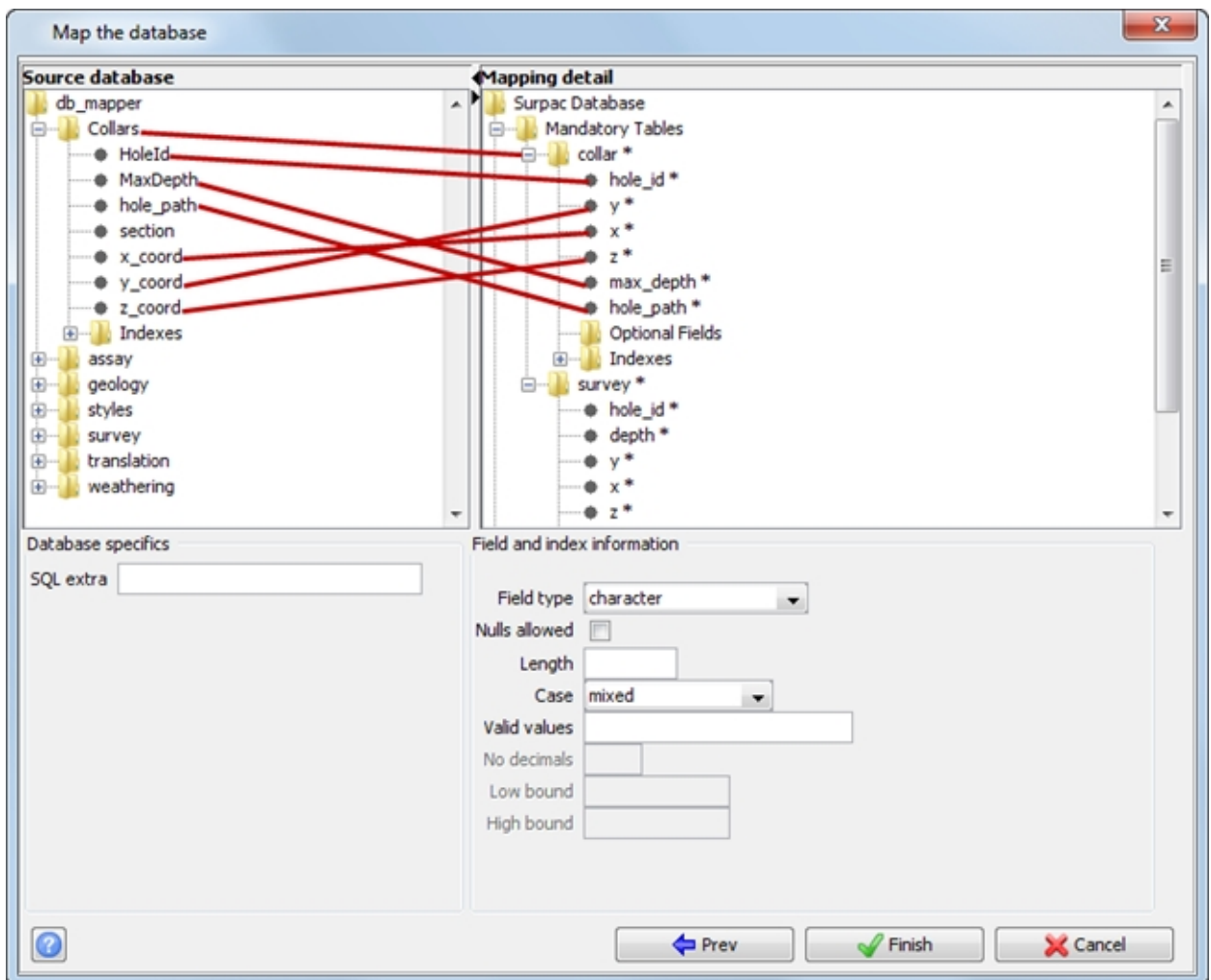

The **hole_path** field does not have to be mapped. If the external database does not have this field, Surpac uses the **CURVED** algorithm for all holes. Fields that are not mapped to the mandatory fields are placed in the **Optional Fields** folder.

4. Drag and drop the **survey** table from the left-hand side to the top of the **survey** table on the right-hand side.
5. Repeat steps 3 and 4 to map each of the remaining mandatory fields for the survey table.



Tip: If you have mapped a Surpac table or field with an incorrect entry in your database, you can remove the mapping by selecting the Surpac table/field name and right-clicking the field. A shortcut menu appears with the options to **Remove** or **Rename**.

6. Under **Collar > Optional Fields**, right-click on the **section** field, and select **Rename**.

7. Rename the **section** field to **my_section**.

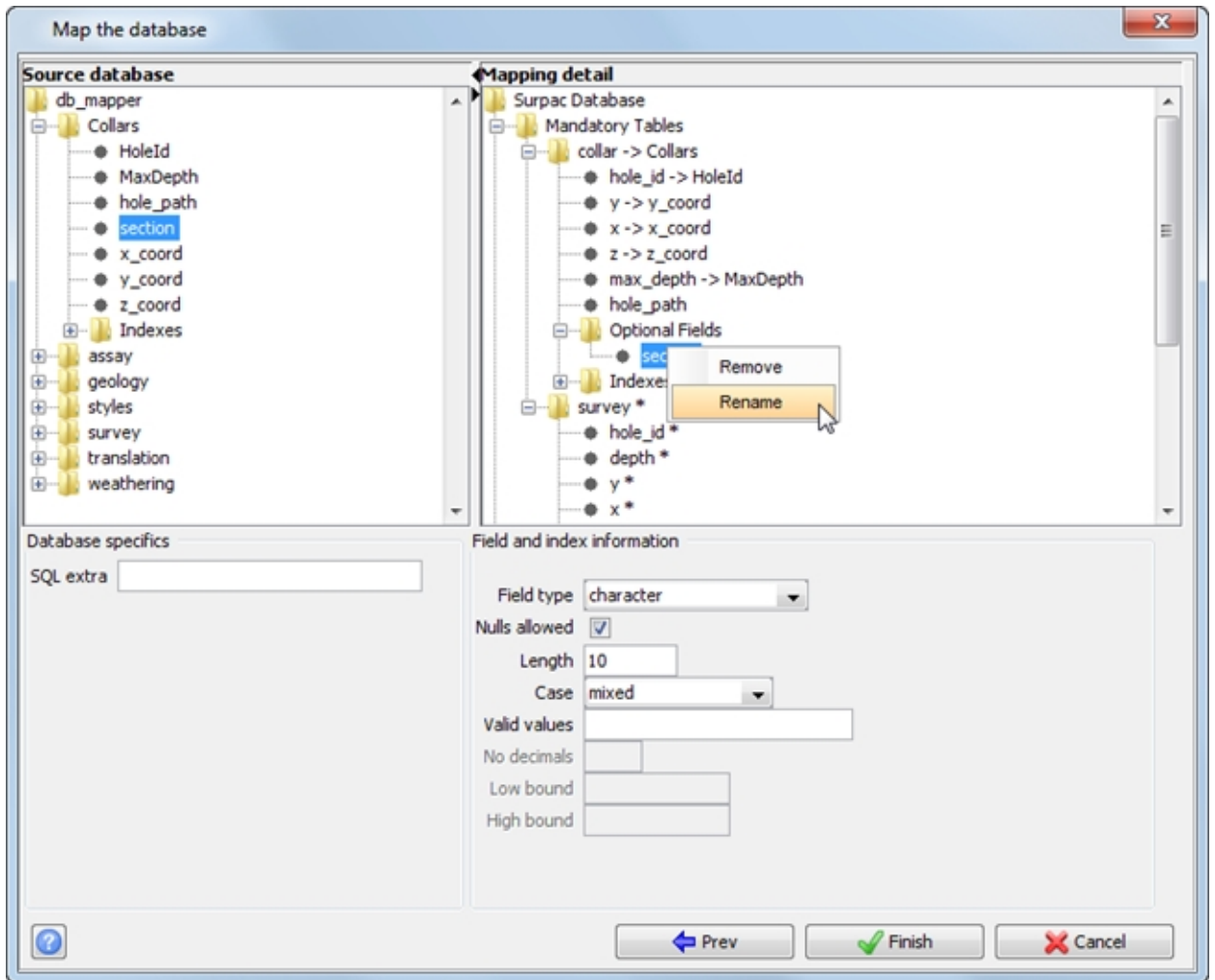

 **Note:** This is only a label for the field and does not change the actual field name in your Access database.

8. Map the **geology** table.

The interval, point, and discrete tables allow you to map tables such as sample, geology, weathering, and geochem.

- a. Drag and drop the **geology** folder on the left to the **Interval tables** folder on the right and map the mandatory fields.
- b. In the **geology** table, under **Optional Fields**, rename the **rock** field to **lithology**.

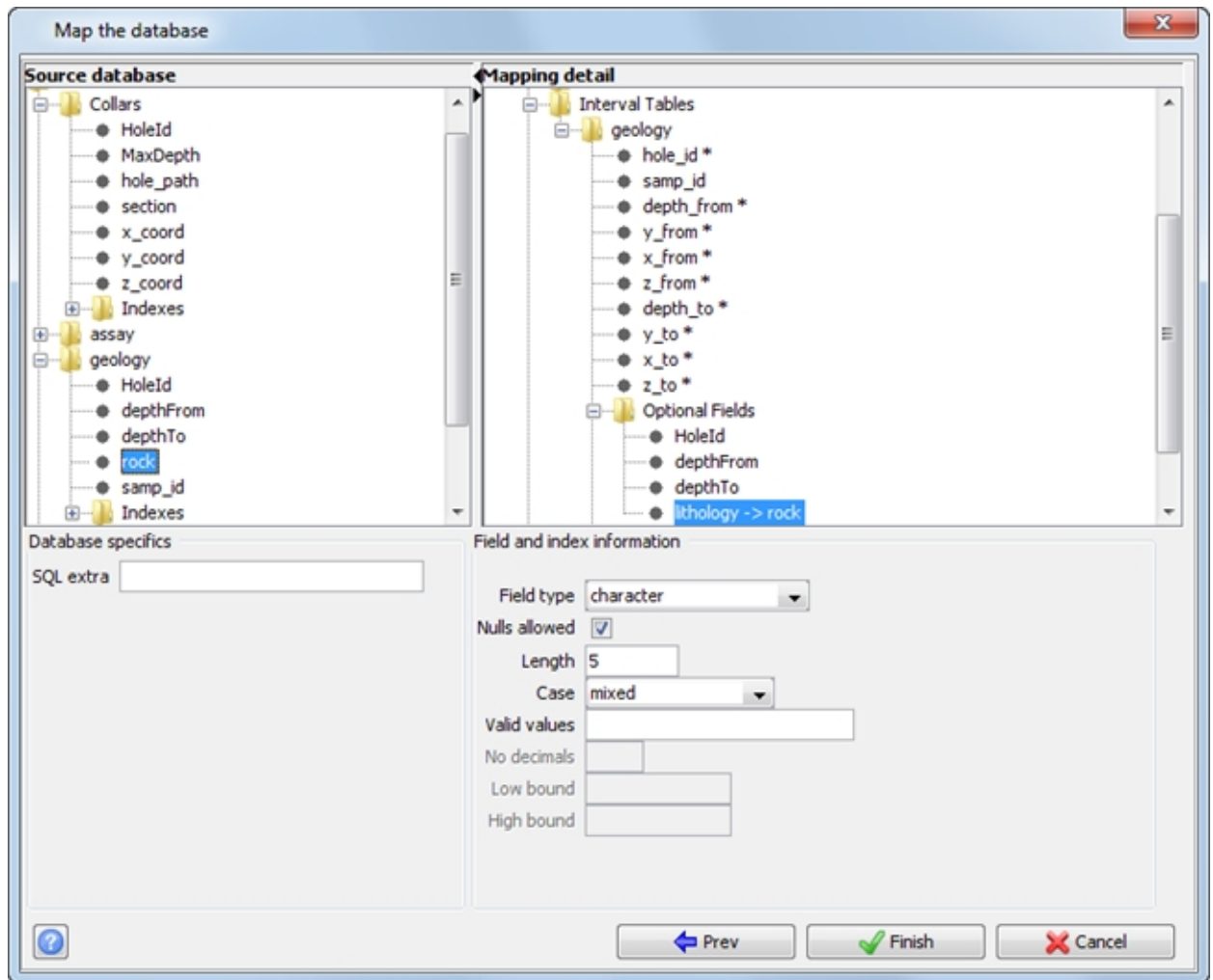

The geology folder contains all the mandatory Surpac fields and a folder to add in optional fields and indexes.

9. Click **Finish**.

 **Note:** For an interval table, the field **samp_id** is specified as a mandatory field. However you do not need to map this field if your interval table is a geology table. All fields with an asterisk (*) next to their name **must** be mapped.

10. Choose **Database > Close**.

After you have finished mapping your database, a **.ddb** file is produced which Surpac can use to connect to the database. If you rename or change the configuration of your database, you can use the **DB MAPPER** function to update the new changes.

Connecting to a Surpac database

Connect to a Surpac database

Task: Connect to a Surpac database

1. Connect to the Surpac database **surpac_training.ddb**, by either:
 - a. Double-clicking **surpac_training.ddb** in the Navigator.
 - b. Dragging **surpac_training.ddb** into **Graphics**.
 - c. Choosing **Database > Open/New** and navigating to **surpac_training.ddb**.

A message is displayed in the **message window** stating that the database is connected and the database name appears in the Status bar.

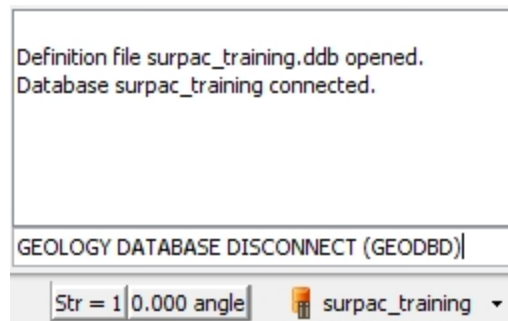

2. Choose **Database > Close**.

Importing and viewing data

Import data

Task: Import data from text files

You will import geology and sample data into the database.

1. Open **sample.txt** in a text editor

The fields are comma delimited and represent **depth_from**, **depth_to**, **gold**, **hole_id**, and **sample_id**.

```
0.000, 2.000, 0.030, WD004, WS689231
2.000, 4.000, 0.020, WD004, WS689232
4.000, 6.000, 1.000, WD004, WS689233
6.000, 8.000, 1.000, WD004, WS689234
8.000, 10.000, 0.130, WD004, WS689235
10.000, 12.000, 0.100, WD004, WS689236
12.000, 14.000, 0.070, WD004, WS689237
14.000, 15.400, 0.360, WD004, WS689238
15.400, 16.000, 2.890, WD004, WS689239
16.000, 16.650, 3.470, WD004, WS689240
16.650, 18.000, 0.180, WD004, WS689241
18.000, 20.000, 0.090, WD004, WS689242
20.000, 22.000, 0.190, WD004, WS689243
22.000, 24.000, 0.040, WD004, WS689244
24.000, 26.000, 1.000, WD004, WS689245
26.000, 27.000, 0.560, WD004, WS689246
27.000, 28.000, 0.490, WD004, WS689247
28.000, 30.000, 1.000, WD004, WS689248
30.000, 32.000, 0.010, WD004, WS689249
32.000, 34.000, 0.120, WD004, WS689250
34.000, 36.000, 0.020, WD004, WS689251
36.000, 38.000, 0.010, WD004, WS689252
38.000, 40.000, 0.010, WD004, WS689253
40.000, 42.000, 1.000, WD004, WS689254
42.000, 44.000, 1.000, WD004, WS689255
44.000, 46.000, 1.000, WD004, WS689256
46.000, 48.000, 1.000, WD004, WS689257
48.000, 50.000, 1.000, WD004, WS689258
```

2. Close the file.
3. Open **geology.txt** in a text editor.

The fields are comma delimited and represent **depth_from**, **depth_to**, **hole_id**, and **lithology**.

```
0.000, 2.000, WD004, S2,
2.000, 6.000, WD004, SH,
6.000, 15.400, WD004, ST,
15.400, 16.650, WD004, QV1,
16.650, 58.650, WD004, ST,
58.650, 64.350, WD004, QV1,
64.350, 100.000, WD004, ST,
0.000, 1.500, WD005, S2,
1.500, 4.000, WD005, SH,
4.000, 24.000, WD005, ST,
24.000, 37.750, WD005, QV1,
37.750, 61.700, WD005, ST,
61.700, 77.600, WD005, QV1,
77.600, 100.000, WD005, ST,
0.000, 4.500, WD011, S2,
4.500, 8.000, WD011, SH,
8.000, 88.700, WD011, ST,
88.700, 99.150, WD011, QV1,
99.150, 117.500, WD011, ST,
117.500, 124.500, WD011, QV1,
124.500, 130.000, WD011, ST,
0.000, 0.500, WD016, S2,
0.500, 1.500, WD016, SH,
1.500, 81.500, WD016, ST,
81.500, 87.600, WD016, QV1,
87.600, 102.800, WD016, ST,
102.800, 113.750, WD016, QV1,
113.750, 133.000, WD016, ST,
```

4. Close the file.

5. Connect to **add_optional_tables.ddb**.
6. Choose **Database > Import data**.
7. Enter the information as shown, and click **Apply**.

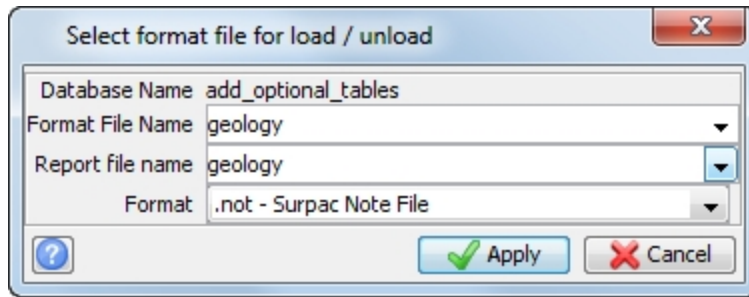

If a format file of the same name exists it will be used.

Note: Surpac does not check whether the format file matches the data to be imported.

If no format file exists, the following form is displayed.

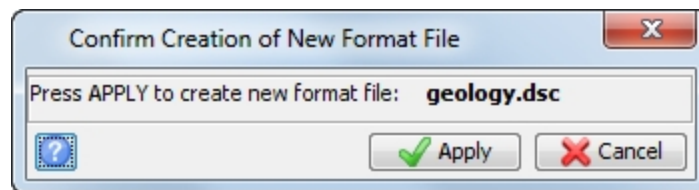

8. Click **Apply**.
This creates a format file which, if the structure of the text file being imported remains the same, can be used each time you import data in the same format.
9. Select the tables that you want to insert the data into, in this case the **geology** and **sample** tables.

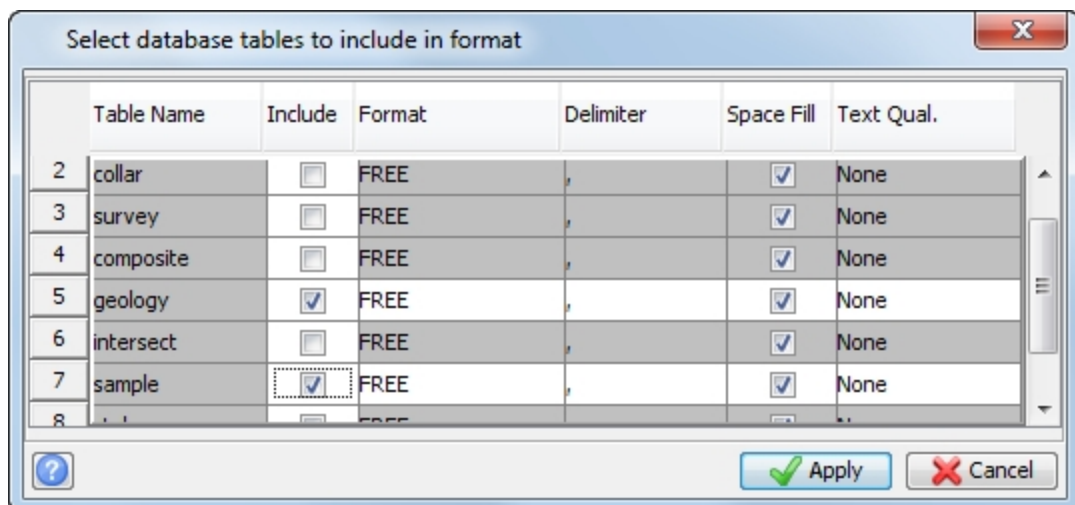

Note: Make sure you scroll down and clear the check boxes for tables at the bottom of the list.

10. Click **Apply**.

- Select the field names you want to include for the geology and sample tables, and enter the column number of the data in the text file as shown.

Select fields to include in format

	Table Name	Field Name	Include	Column	Length	Format
1	geology	hole_id	<input checked="" type="checkbox"/>	3	0	FREE
2		samp_id	<input type="checkbox"/>	2	0	FREE
3		depth_from	<input checked="" type="checkbox"/>	1	0	FREE
4		y_from	<input type="checkbox"/>	0	0	FREE
5		x_from	<input type="checkbox"/>	0	0	FREE
6		z_from	<input type="checkbox"/>	0	0	FREE
7		depth_to	<input checked="" type="checkbox"/>	2	0	FREE
8		y_to	<input type="checkbox"/>	0	0	FREE
9		x_to	<input type="checkbox"/>	0	0	FREE
10		z_to	<input type="checkbox"/>	0	0	FREE
11		lithology	<input checked="" type="checkbox"/>	4	0	FRFF

Apply Cancel

Select fields to include in format

	Table Name	Field Name	Include	Column	Length	Format
12	sample	hole_id	<input checked="" type="checkbox"/>	4	0	FREE
13		samp_id	<input checked="" type="checkbox"/>	5	0	FREE
14		depth_from	<input checked="" type="checkbox"/>	1	0	FREE
15		y_from	<input type="checkbox"/>	0	0	FREE
16		x_from	<input type="checkbox"/>	0	0	FREE
17		z_from	<input type="checkbox"/>	0	0	FREE
18		depth_to	<input checked="" type="checkbox"/>	2	0	FREE
19		y_to	<input type="checkbox"/>	0	0	FREE
20		x_to	<input type="checkbox"/>	0	0	FREE
21		z_to	<input type="checkbox"/>	0	0	FREE
22		hole	<input checked="" type="checkbox"/>	3	0	FRFF

Apply Cancel

- Click **Apply**.

13. Select the **Text File Name** and **Load Type** for the tables.

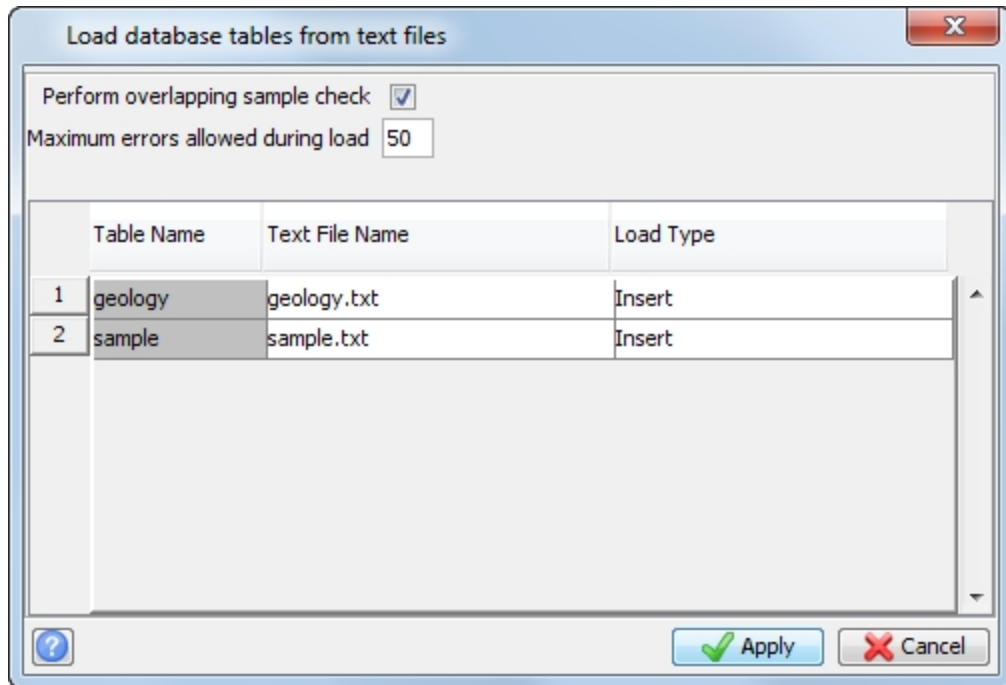

Note: If you select **Perform overlapping sample check**, an error is recorded in the report file if the data for any holes overlaps. Allowing a small number of errors before the process stops can be useful. These error records do not go into the database, they are stored in a reject file with an explanation for the error.

Note: The **Insert** option does not replace existing data in the database; the **Update** option does replace existing data in the database.

14. Click **Apply**.

The following is a sample reject file, where a header record has been read as an error and sent to the reject file with two other rejected records.

```
18.000, 20.000, 0.090, XD004, WS689242
20.000, 22.000, 0.190, WD004, WS689243
```

An explanation of the errors is given in the report file.

```

Database Management - Database Load Report

Date       : 11-Apr-12
Database   : add_optional_tables
Format_file : geology.dsc
=====

#####
Loading Table : geology from file geology.txt
#####

    453 records were inserted.
    0 records were updated.
    0 records were rejected.

    Performing sample overlap checks
    no overlapping samples were found

#####
Loading Table : sample from file sample.txt
#####
Warning: Hole ID does not exist in the collar table
18.000, 20.000, 0.090, XD004, W5689242

Warning: Record already exists, duplicate ignored
20.000, 22.000, 0.190, WD004, W5689243

    4813 records were inserted.
    0 records were updated.
    2 records were rejected.

    Performing sample overlap checks
Sample (W5689233) from hole (WD004) with interval (4.00 - 6.00)
overlaps previous sample (W5689232) with interval (2.00 - 4.50)

    overlapping sample check complete

Page 1 of 1
    
```

 **Note:** To see all of the steps in this section, run **02a_importing_data.tcl**. You need to click **Apply** on any forms presented.

Viewing data

You can view data directly from the Access database by dragging the **.mdb** , or **.accdb**, file into the graphics workspace. After the data has been imported, you can view and edit tables using options from the **Edit** menu.

When selecting **View table constrained**, the **Define Query Constraints** form allows the data to be filtered depending on the values for a particular field from that table. You can also use multiple constraints, but all of the conditions must be met for the data to be displayed.

Task: View data in a table with constraints

1. Connect to **surpac_training.ddb**.
2. Choose **Edit > View table constrained**.
3. Enter the information as shown, and click **Apply**.

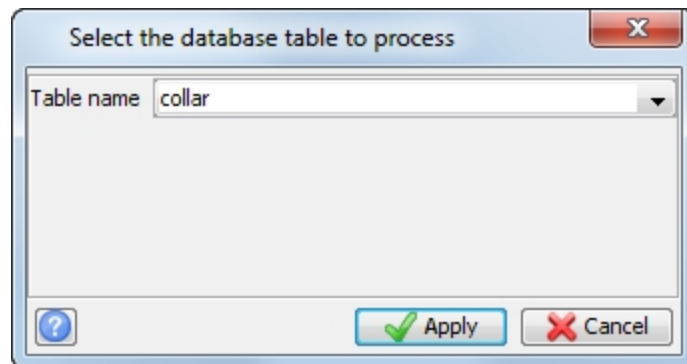

The *Define view/edit rows template* form is displayed.

4. Click **Apply**.

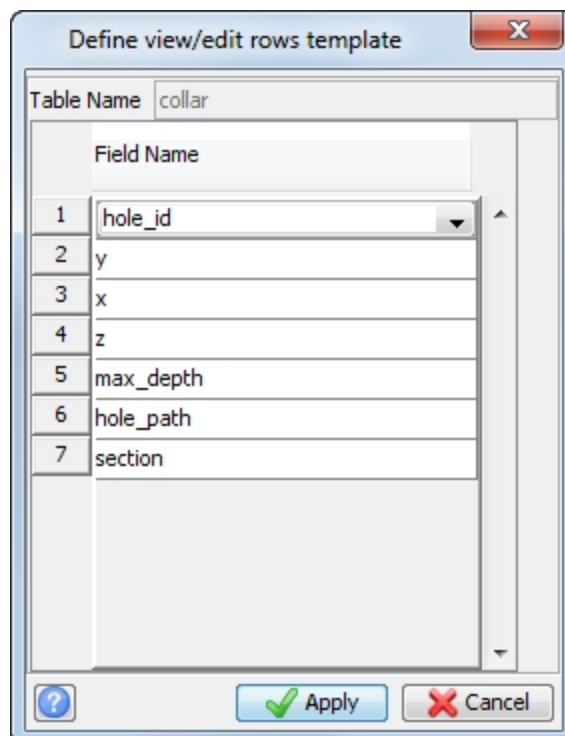

5. Enter the information as shown, and click **Apply**.

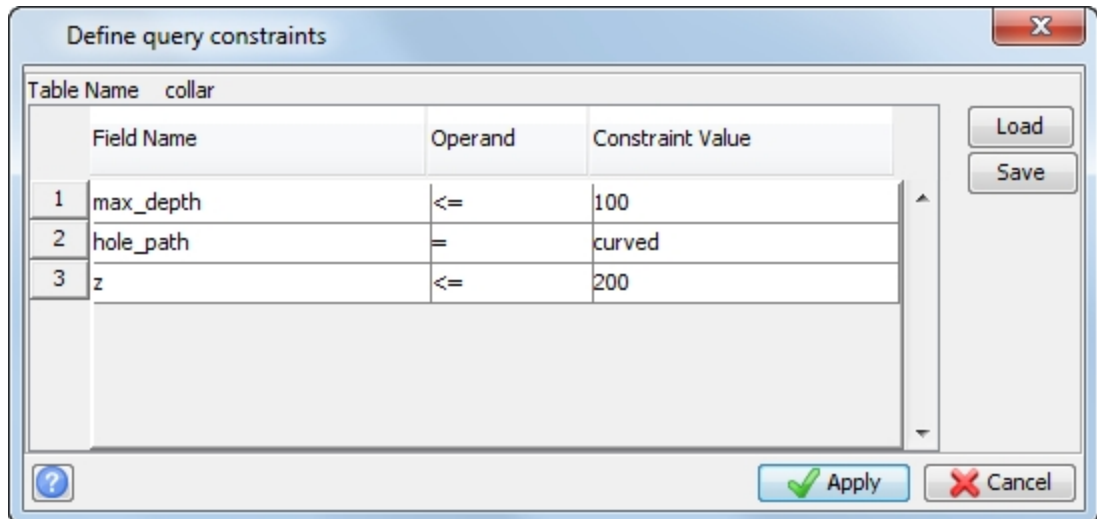

Note: Right-click in the space below the current row and select **Add** from the shortcut menu to add a new row.

The holes that meet all three of the above constraints are displayed.

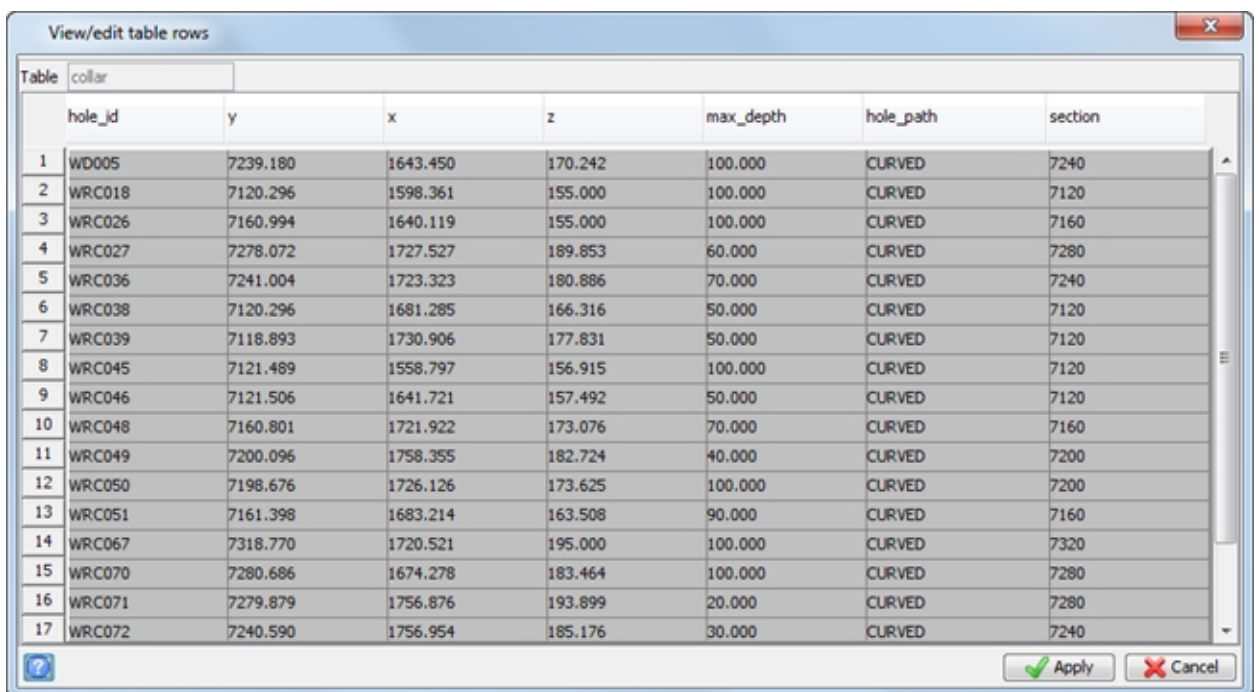

6. Click **Apply**.
7. Close the database.

Note: To see all of the steps in this task, run **02b_viewing_data.tcl**. You need to click **Apply** on any forms presented.

Display drillholes

Task: Display drillholes

1. Connect to **surpac_training.ddb**.
2. Click the **surpac_training** icon on the Status bar, and select **Display drillholes**.

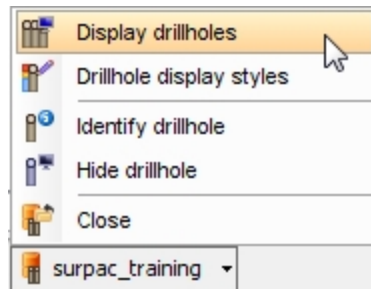

3. Enter the information as shown, and click **Apply**.

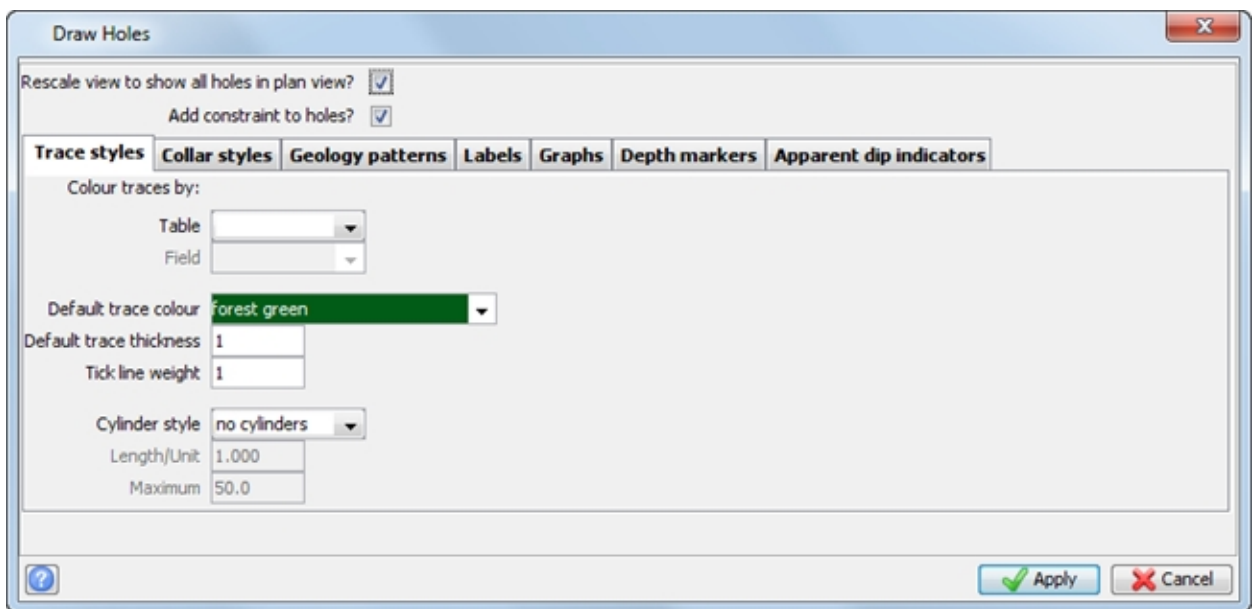

The *Define query constraints* form is displayed.

4. Click **Apply**.

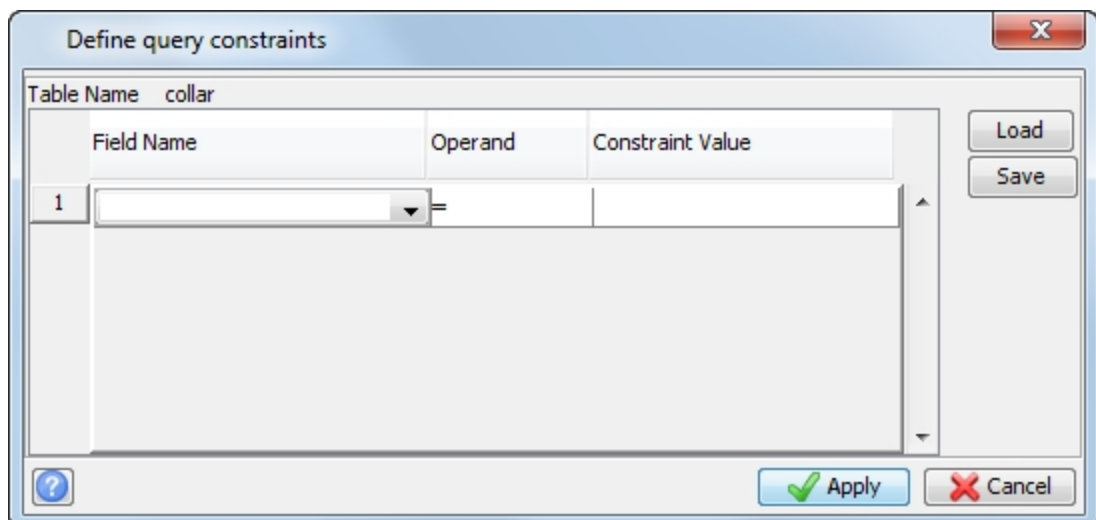

The drillholes are displayed in plan view.

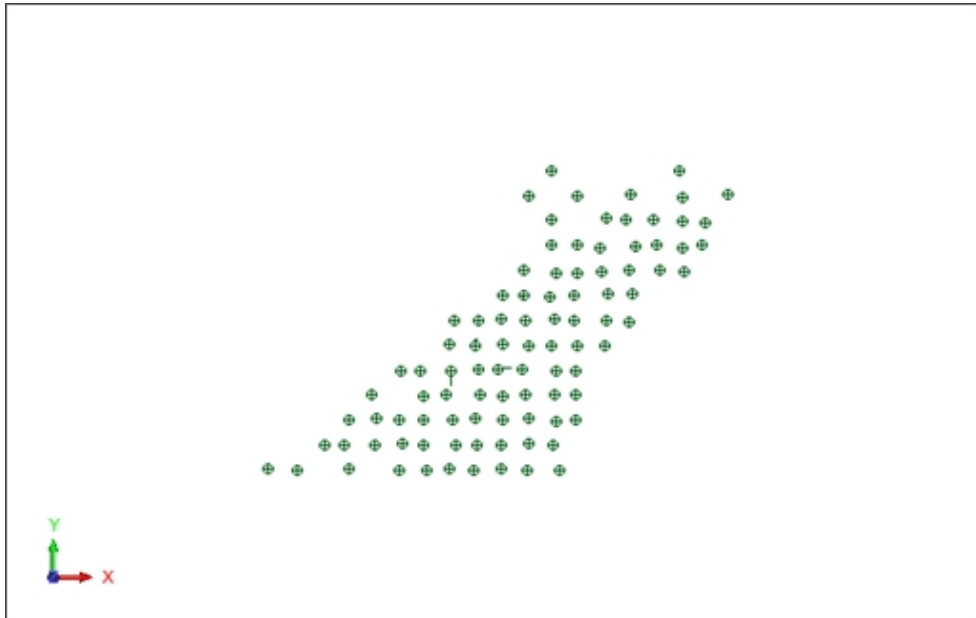

When the drillholes are rotated you can see that despite colouring the traces by assay, everything is green. This is because no styles have been setup to display the data. Next, you create colour display styles for the lithology and assays.

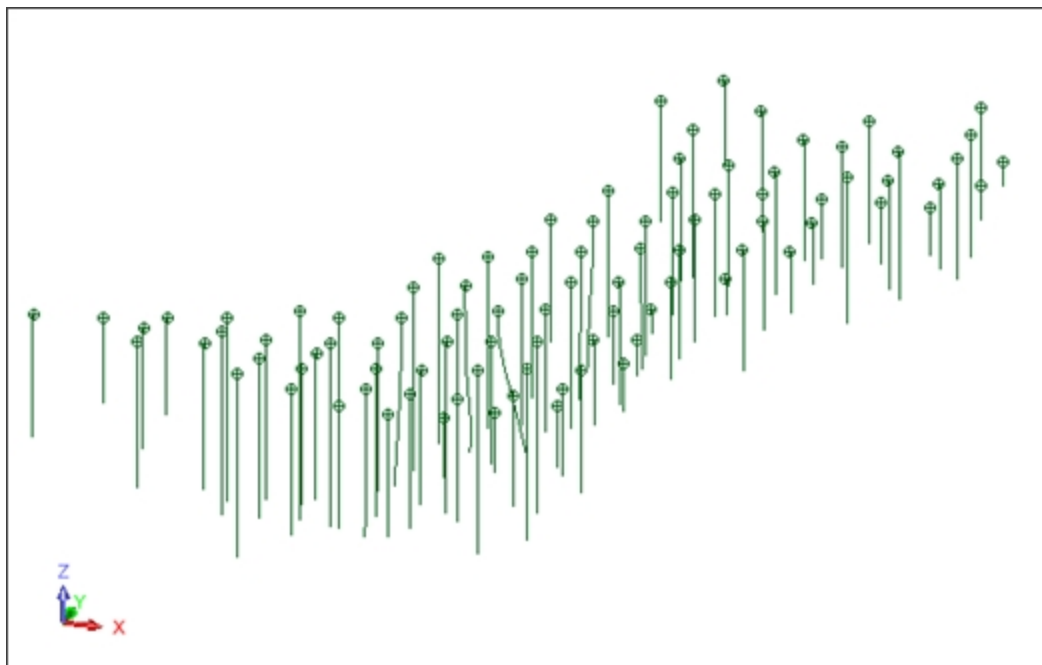

 **Note:** To see all of the steps in this task, run `03a_display_drillholes_no_styles.tcl`. You need to click **Apply** on any forms presented.

Task: Apply styles to drillholes

1. Choose **Display > Drillhole display styles**.
2. Expand the **geology** folder and locate the **lithology** field.

3. Right-click on the **lithology** field and choose **Get field codes** from the shortcut menu.

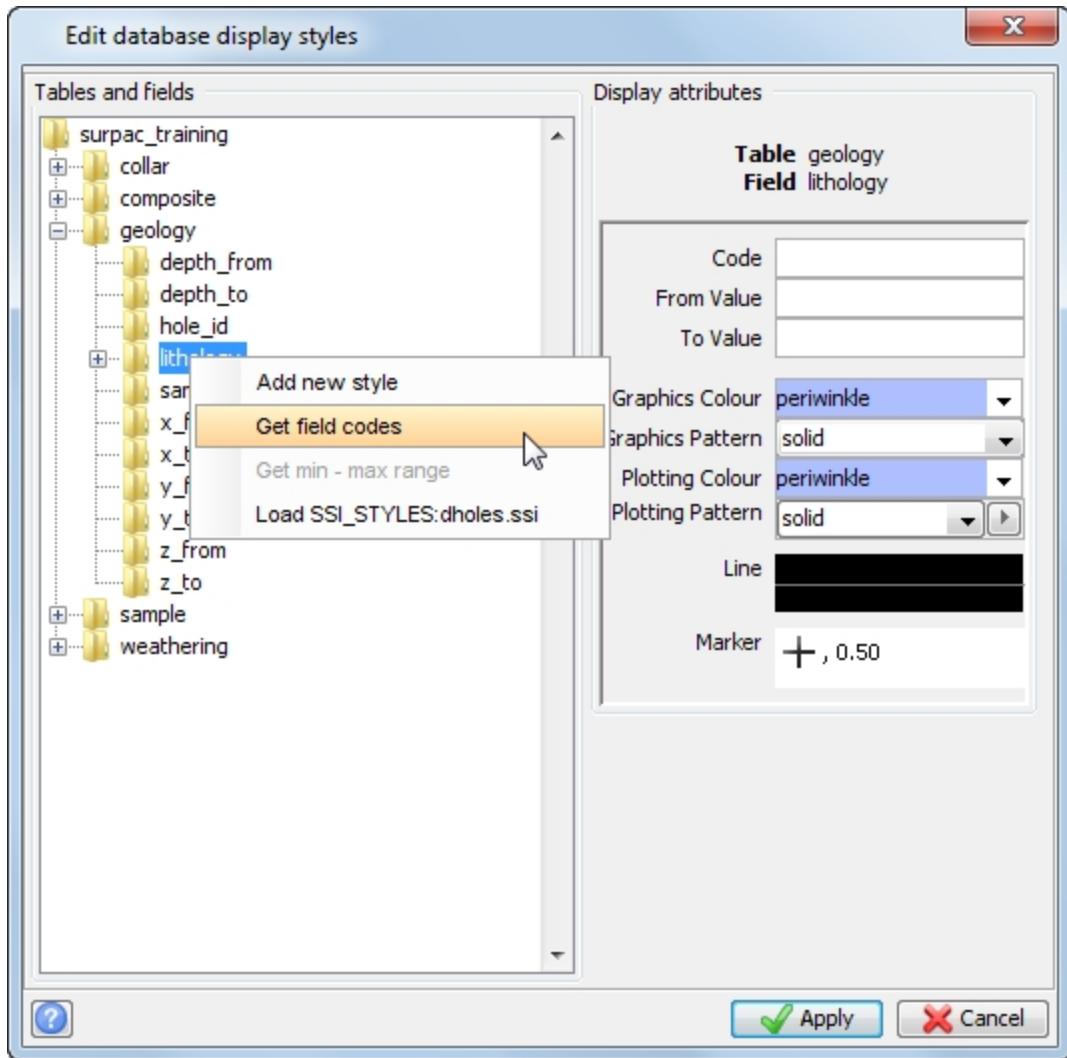

This adds all 7 unique lithological codes to the list.

4. Expand the **lithology** folder.
5. For each of the 7 lithological codes, select a different colour for **Graphics** and plotting.
For example:

B	Yellow
IN	Green
MU	Blue
QV1	Red
S2	Orange
SH	Cyan
ST	Magenta

Codes can be grouped together. For example, if there was a series of codes beginning with the letter M, they could be all coded purple. Or, relating to the lithology example, S* Orange, would mean that S2, SH and ST would all plot in orange.

M*	Purple
S*	Orange

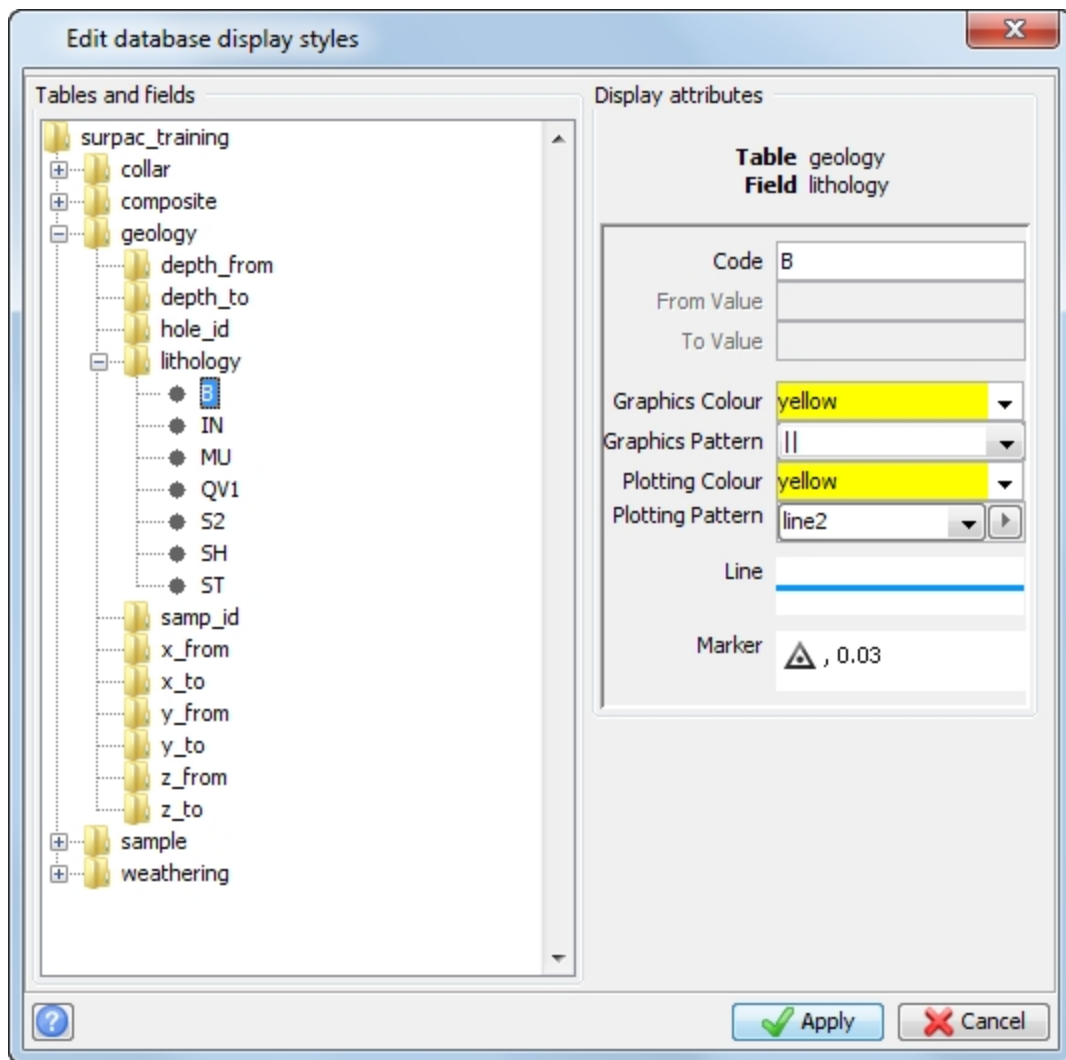

6. Expand the **sample** folder to find the **gold** field.

- Right-click the gold field and choose **Get min – max range** from the shortcut menu.

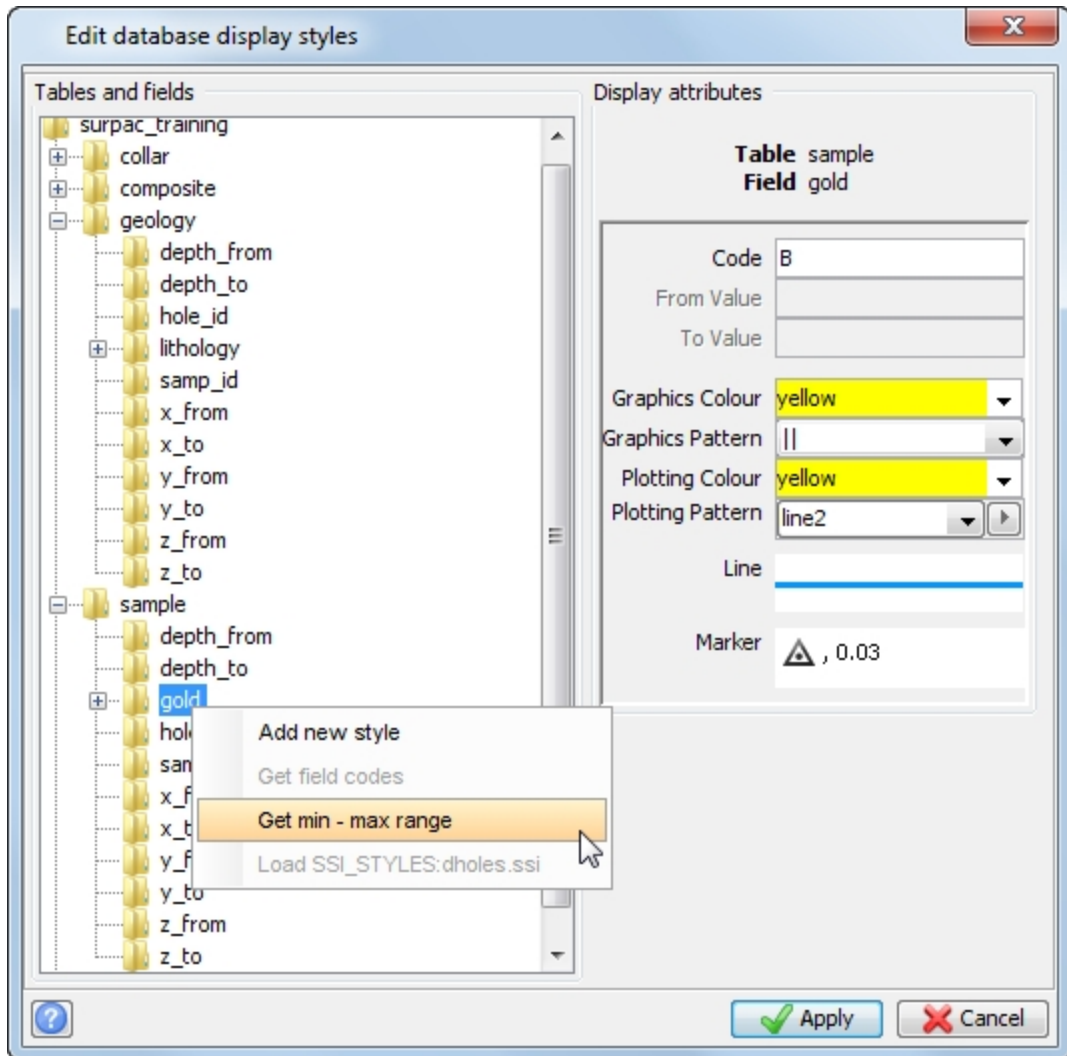

This adds one grade range that consists of the minimum and maximum values found in the gold field. This provides you with a reference of the range of values currently available in that field.

- On the right-hand side, change the **From Value** to 0, and the **To Value** to 2.
- Choose a colour for this grade range.
- Right-click on the **gold** field and choose **Add new style** from the shortcut menu. This adds a new range below the previous range.
- On the right-hand side, change the **From Value** to 2, and **To Value** to 4.
- Choose a colour for this grade range.
- Continue adding grade ranges in increments of 2 until you reach 10. For example:

0-2	Cyan
2-4	Orange
4-6	Yellow
6-8	Blue
8-10	Red

- Click **Apply**.

Manipulate drillholes

Having set up the drillhole styles, you can now manipulate the display of the drillholes by:

- displaying cylinders
- displaying lithological codes on the right-hand side
- displaying assays on the left-hand side
- displaying colour-filled bar graphs of the gold assays on the left-hand side and off-setting them by 5m

 **Note:** All of the following tasks require that you are connected to the database **surpac_training.ddb**.

Task: Display cylinders

You can use display cylinders to view high grade areas. The colour of the cylinder is taken from the styles table, and its size is determined by the numeric value for that field.

1. Choose **Display > Drillholes**.
2. Select the **Rescale view to display all holes in plan view** check box, to allow **Graphics** to resize and display all data after you have applied the changed styles.
3. Clear the **Add constraint to holes** check box, to display all data in **Graphics**.
4. Enter the information as shown, and click **Apply**.

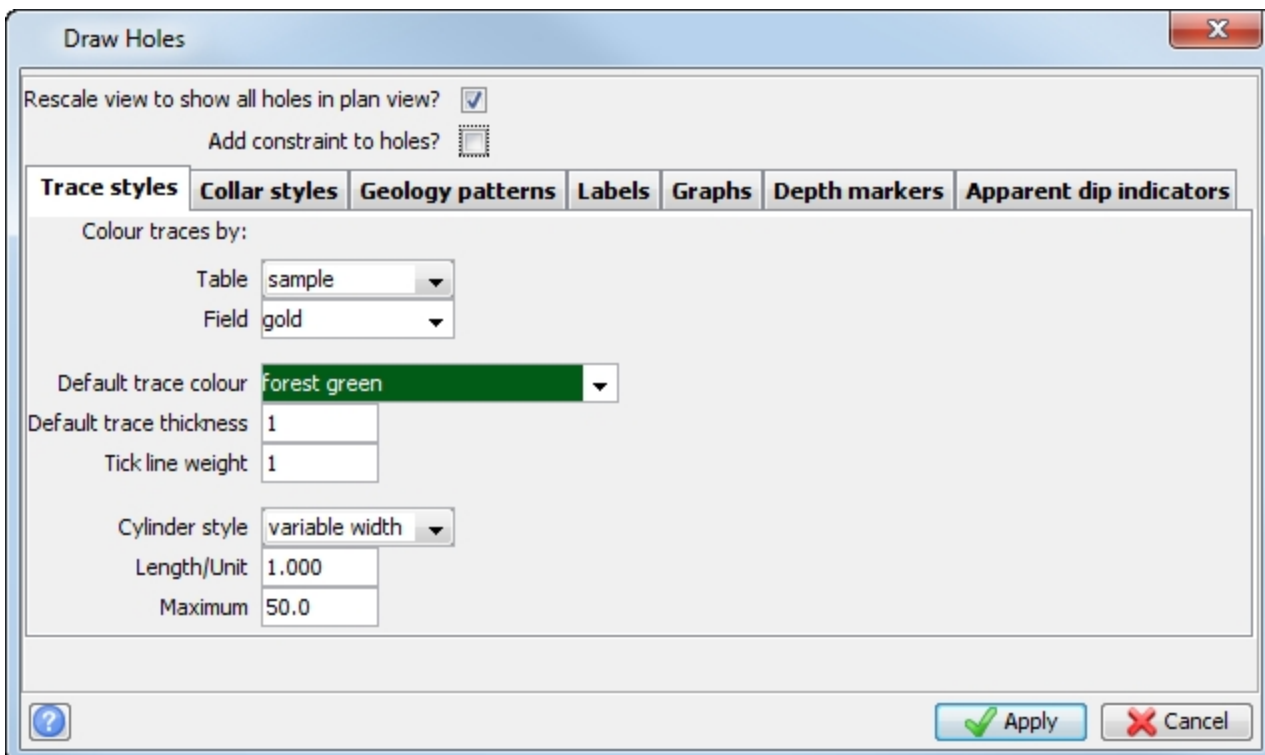

Draw Holes

Rescale view to show all holes in plan view?

Add constraint to holes?

Trace styles | Collar styles | Geology patterns | Labels | Graphs | Depth markers | Apparent dip indicators

Colour traces by:

Table: sample

Field: gold

Default trace colour: Forest green

Default trace thickness: 1

Tick line weight: 1

Cylinder style: variable width

Length/Unit: 1.000

Maximum: 50.0

? Apply Cancel

You can get a sense of how the orebody is trending by viewing and rotating the data in **Graphics**.

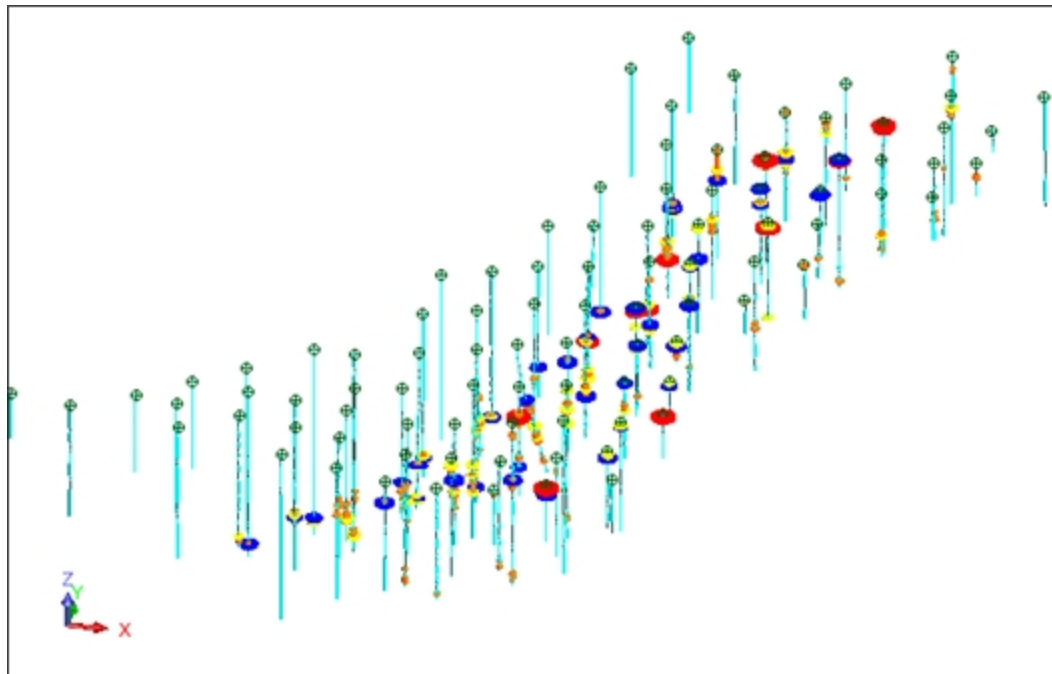

Note: To see all of the steps in this task, run `03b_display_cylinders.tcl`. You need to click **Apply** on any forms presented.

Task: Display lithological codes on the right-hand side

1. Choose **Display > Drillholes**.
2. Enter the information as shown on each the **Trace styles**, **Collar styles**, and **Labels** tabs, and then click **Apply**.

Draw Holes

Rescale view to show all holes in plan view?

Add constraint to holes?

Trace styles | Collar styles | Geology patterns | Labels | Graphs | Depth markers | Apparent dip indicators

Colour traces by:

Table: geology

Field: lithology

Default trace colour: forest green

Default trace thickness: 1

Tick line weight: 1

Cylinder style: no cylinders

Length/Unit: 1.000

Maximum: 50.0

Apply Cancel

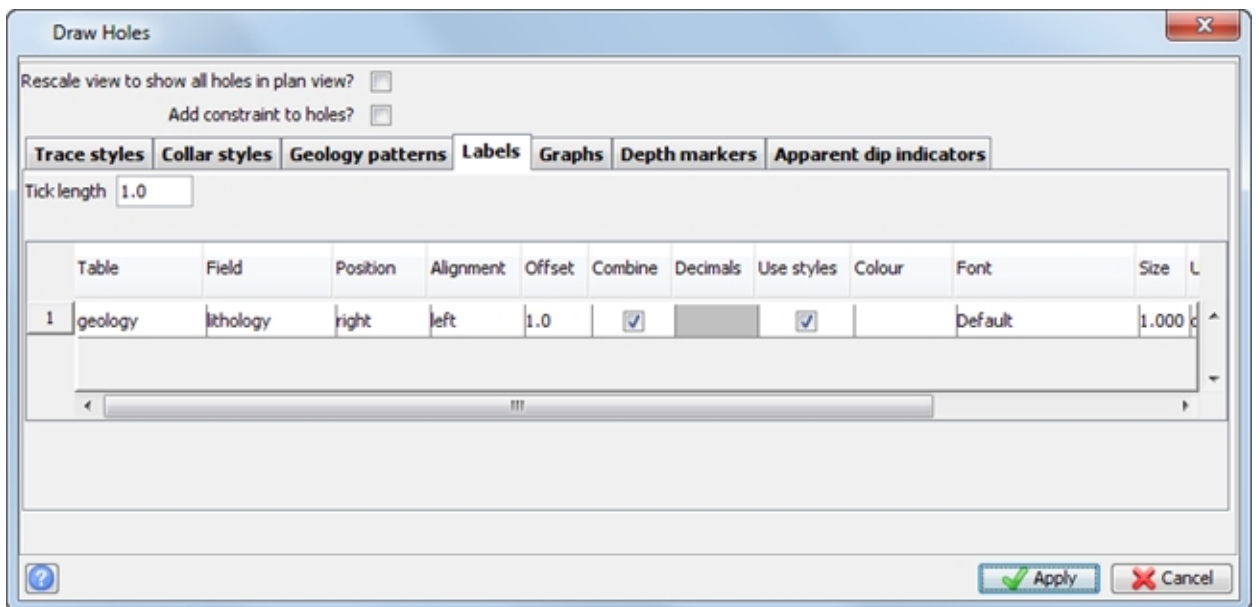
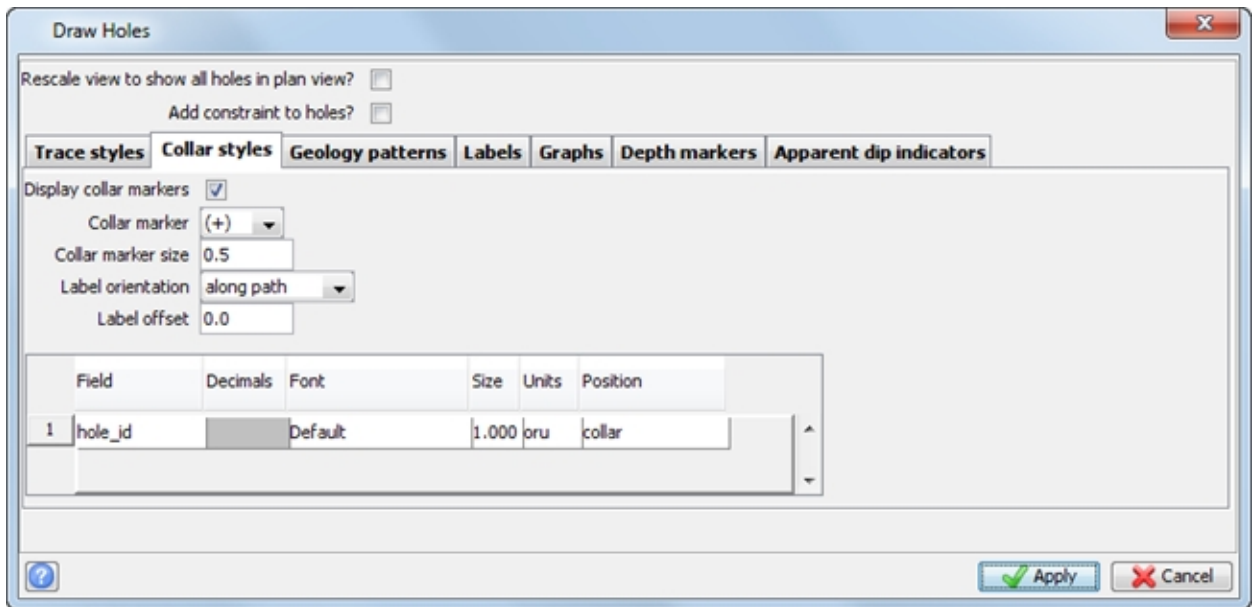

The results are displayed in **Graphics**.



Task: Display assays on the left-hand side

1. Choose **Display > Drillholes**.
2. Enter the information as shown, and click **Apply**.

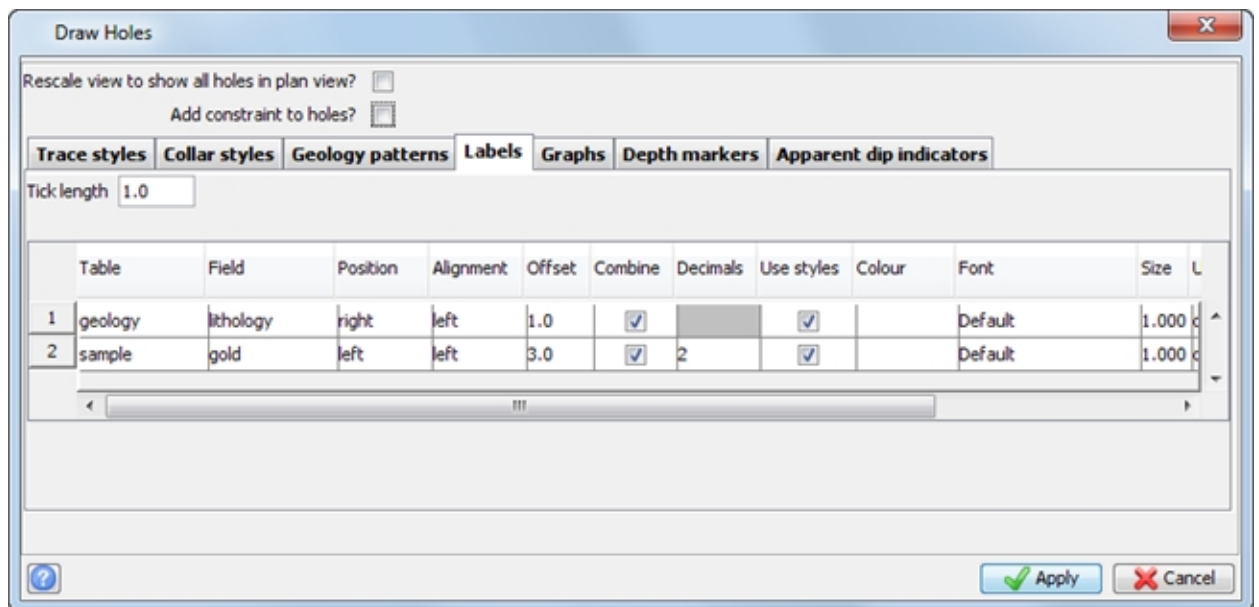

The results are displayed in **Graphics**.

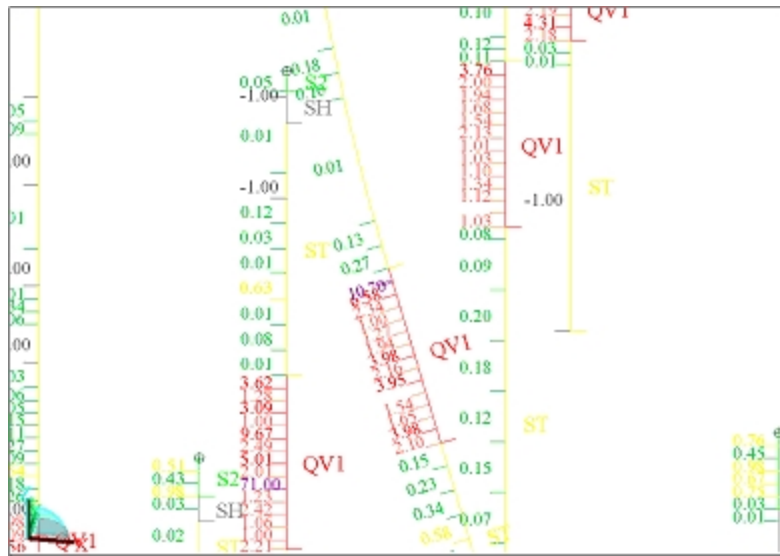

Task: Display colour-filled bar graphs of gold assays on the left-hand side

1. Choose **Display > Drillholes**.
2. Enter the information as shown, and click **Apply**.

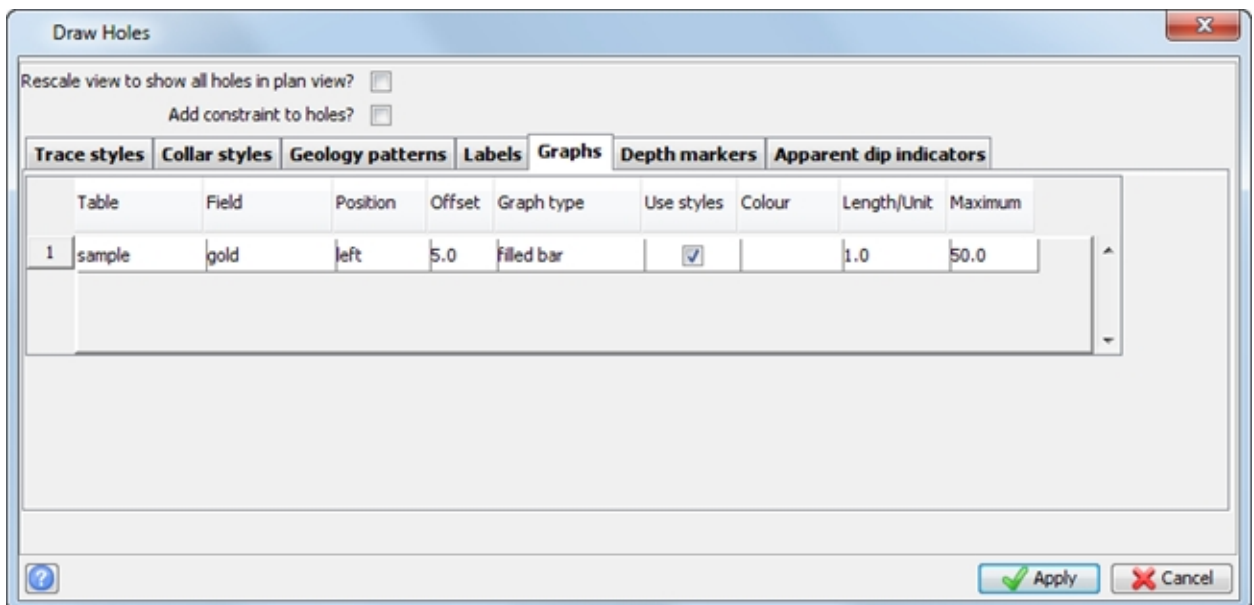

Drillhole investigation and interrogation

Identify drillhole

Task: Run identify drillhole

1. Connect to **surpac_training.ddb**.
2. Click **surpac_training** icon on the Status bar, and choose **Display drillholes**.

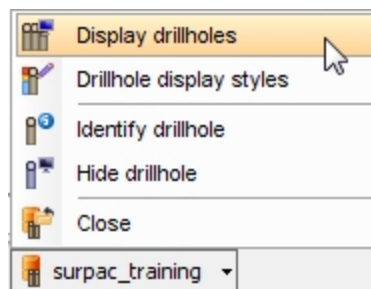

3. Enter the information as shown, and click **Apply**.

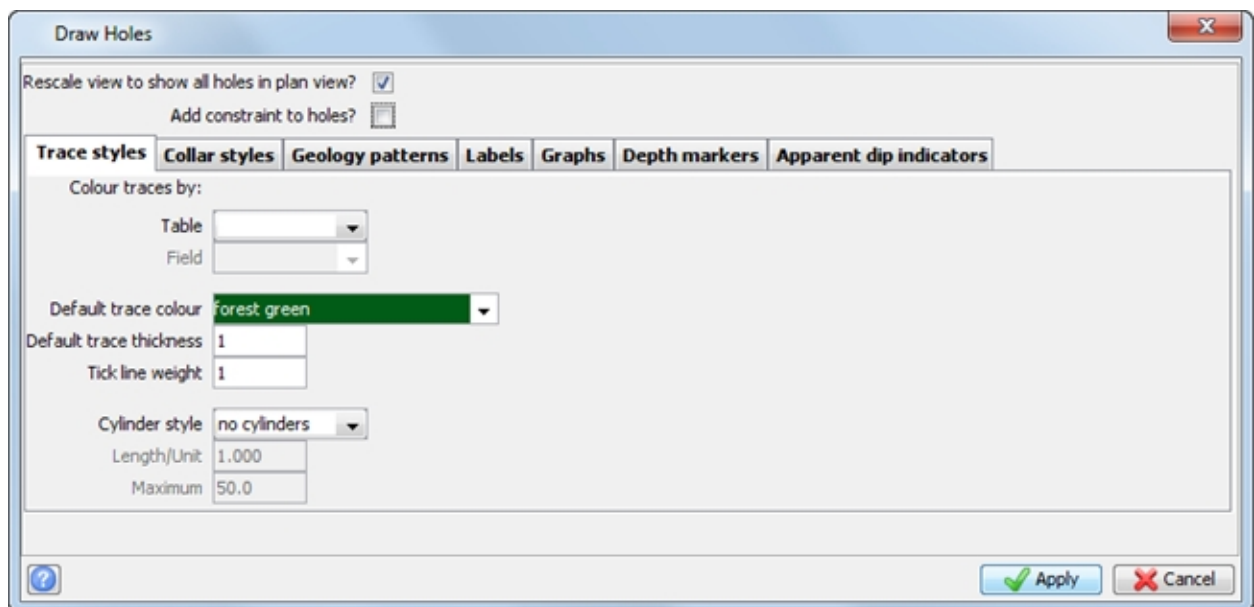

4. Choose **Display > Identify drillhole**.
5. Follow the prompt and click in **Graphics** to select a hole.
6. Press ESC.

A message similar to the following is displayed in the **message window**:

Hole ID: WRC001, Collar Y: 1682.69, Collar X: 7318.77, Collar Z: 191.48, Depth: 120.00

Graphically edit drillhole

Task: Run edit drillhole

1. Choose **Display > Edit drillhole**.
 2. Follow the prompt, and click in **Graphics** to select the hole of interest.
 3. Select the **sample** table and the **gold** field, and then click **Add**.
 4. Select the **geology** table and the **lithology** field, and then click **Add**.
- The results for hole WRC065 are displayed.

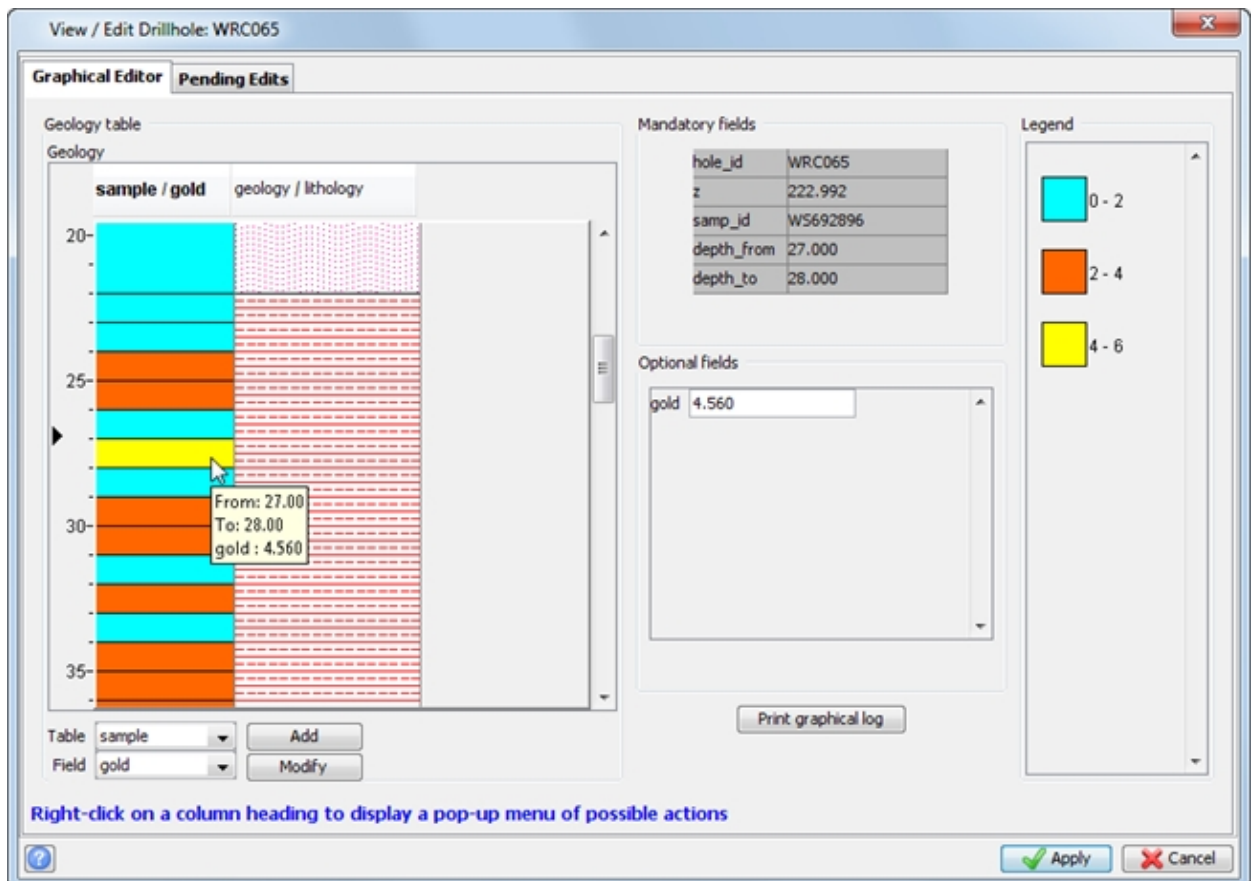

Note: To remove charts from the editor, right-click on the field headings (in this case, sample/gold or geology/lithology) and choose **Remove** from the shortcut menu.

5. Hover the cursor over an interval to see the results.

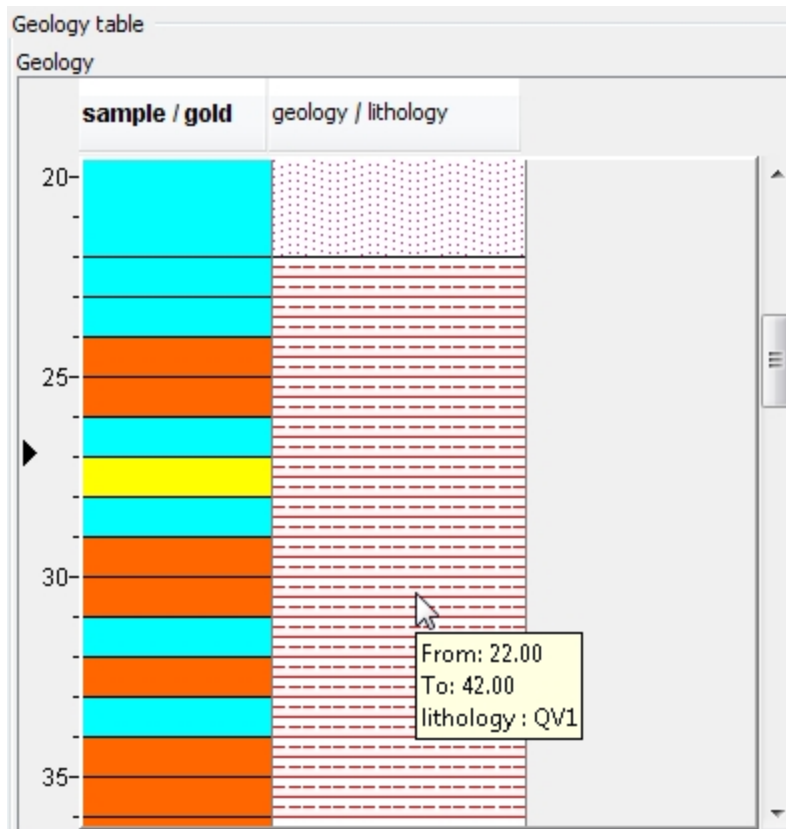

Note: If permissions in the external database allow write-back functions, you can use this function to edit the drillhole database directly.

6. Click **Apply**.
If you have made changes, the *Save edits* form is displayed to prompt you to save or discard the changes.

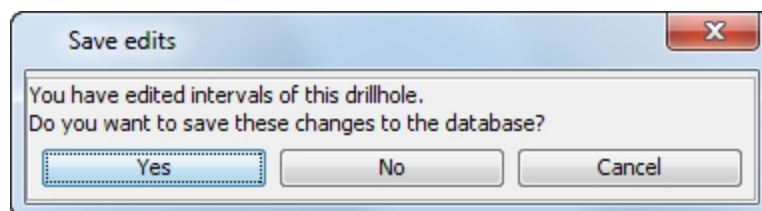

7. Click **No**.

Drillhole sections

Creating sections graphically

Task: Create sections graphically

Note: This task requires that you have successfully performed the previous task so that the drillholes are displayed correctly. If you did not successfully display the drillholes in the last task, run the macro **03c_display_drillholes_with_styles.tcl**.

1. Choose **Section > Define**.
2. Enter the information as shown, and click **Apply**.

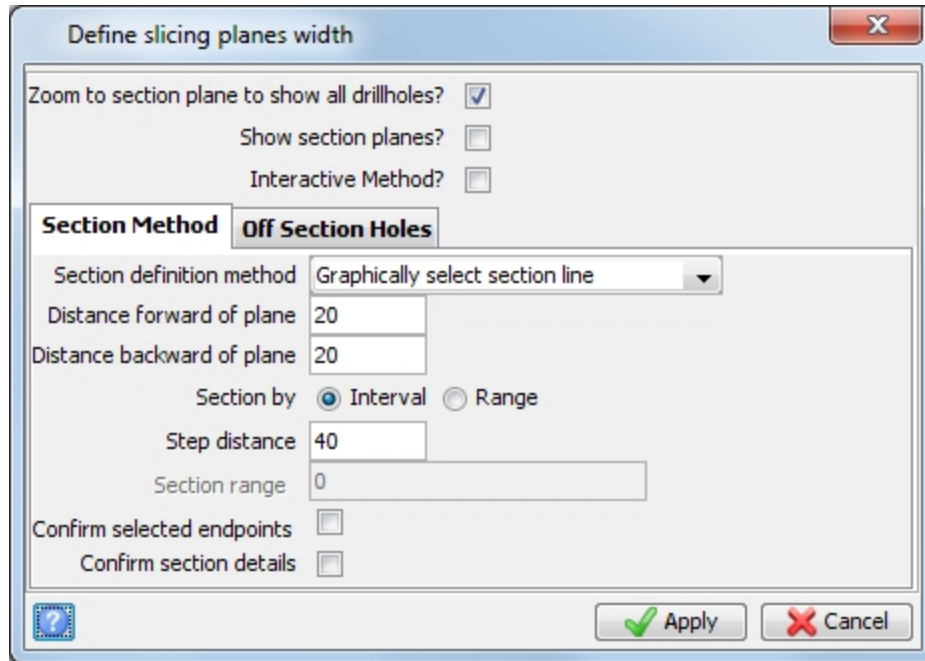

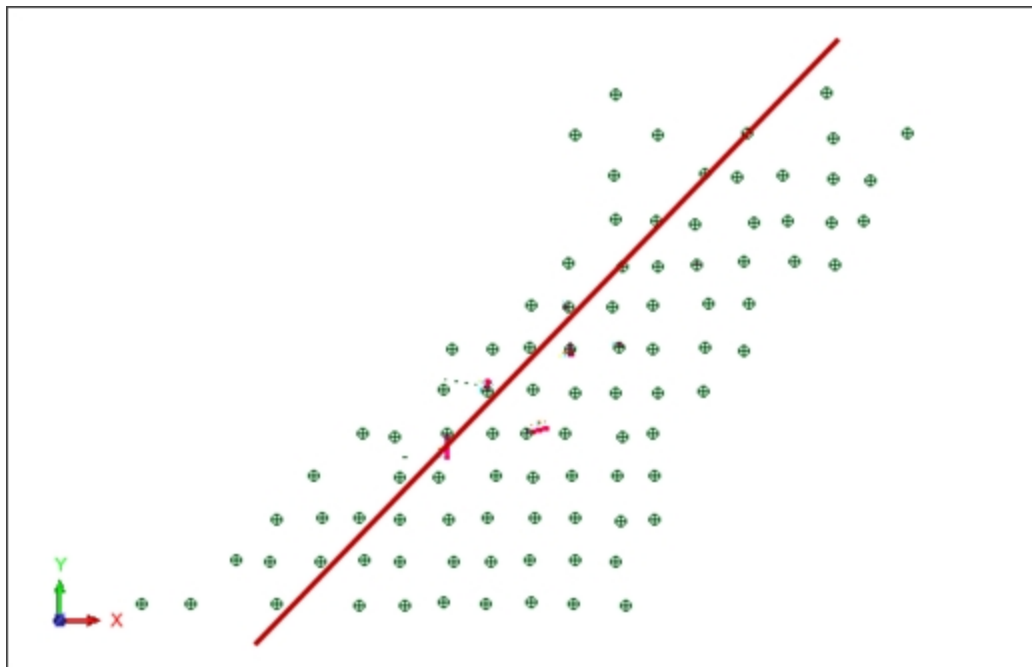

3. Select your section; click and hold the cursor and drag to a point as shown.

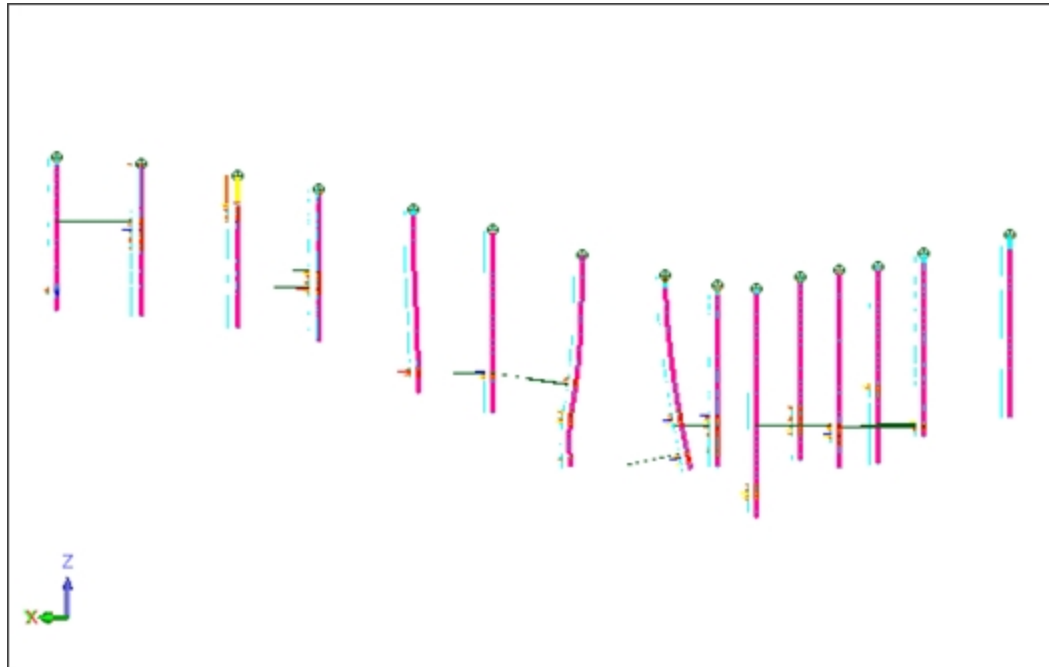

A result similar to the following is displayed.



4. Click **Next section** , to move through the sections.
5. Rotate the section.

 **Tip:** If you want to go back to the zoom plane, choose **View > Zoom > Zoom plane**.

6. Click **End section mode** .

 **Note:** To see all of the steps in this task, run macro **04a_create_sections_graphically.tcl**. You need to **Apply** any forms presented.

Advanced cross-sectional viewing

You can use Surpac to generate a sequence of string slices from DTM or 3DM objects and resident block models, as well as the drillhole database.

Task: Create viewing planes including DTMS and 3DMS

1. Run macro **03c_display_drillhole_with_styles.tcl**.
2. Open **topo1.dtm**, **pit1.dtm** and **ore1.dtm** in **Graphics**.
3. Click **Section view**.

The surfaces, solid, and drill holes are displayed.

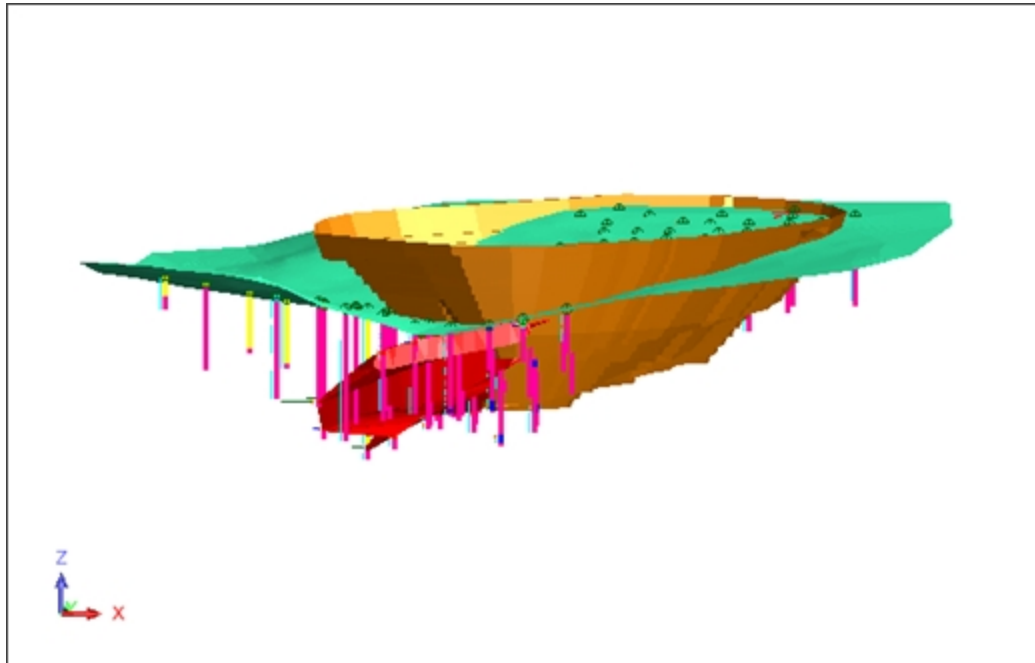

4. Use the transparency slider toolbar to view the data through these rendered surfaces.

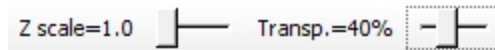

Note: To make the transparency slider toolbar available, right-click in the empty space next to the menus, choose **Toolbars**, and then select **Scale and transparency**.

5. Choose **Planes > Quick planes**.

6. Enter the information as shown, and click **Apply**.

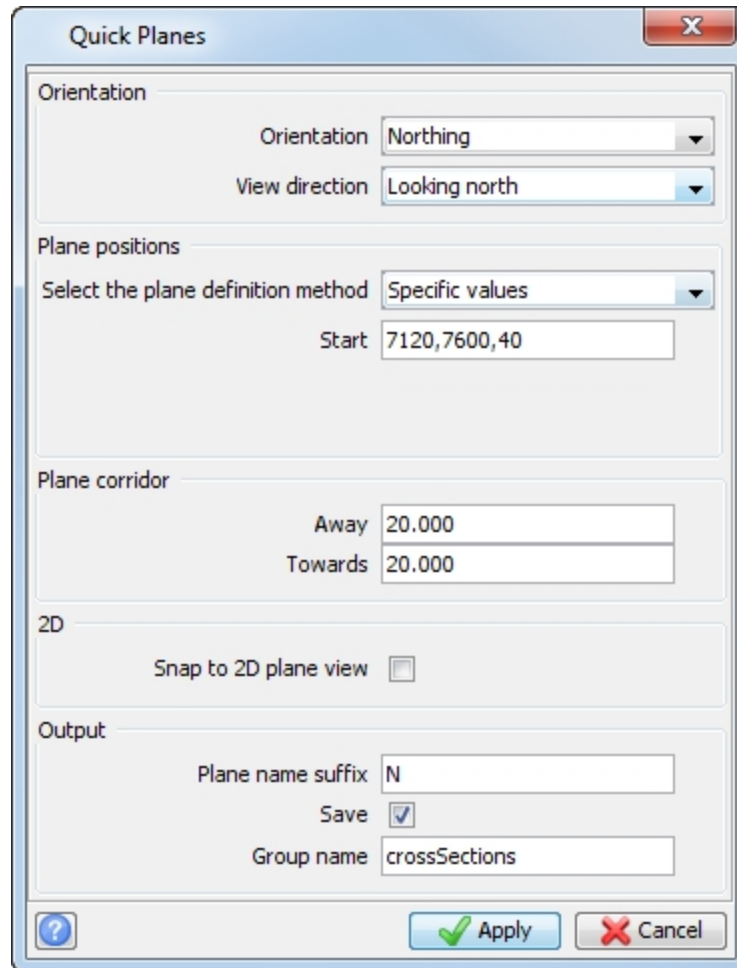

7. In the **Planes** panel, click **Next plane**  to move through all of the sections.

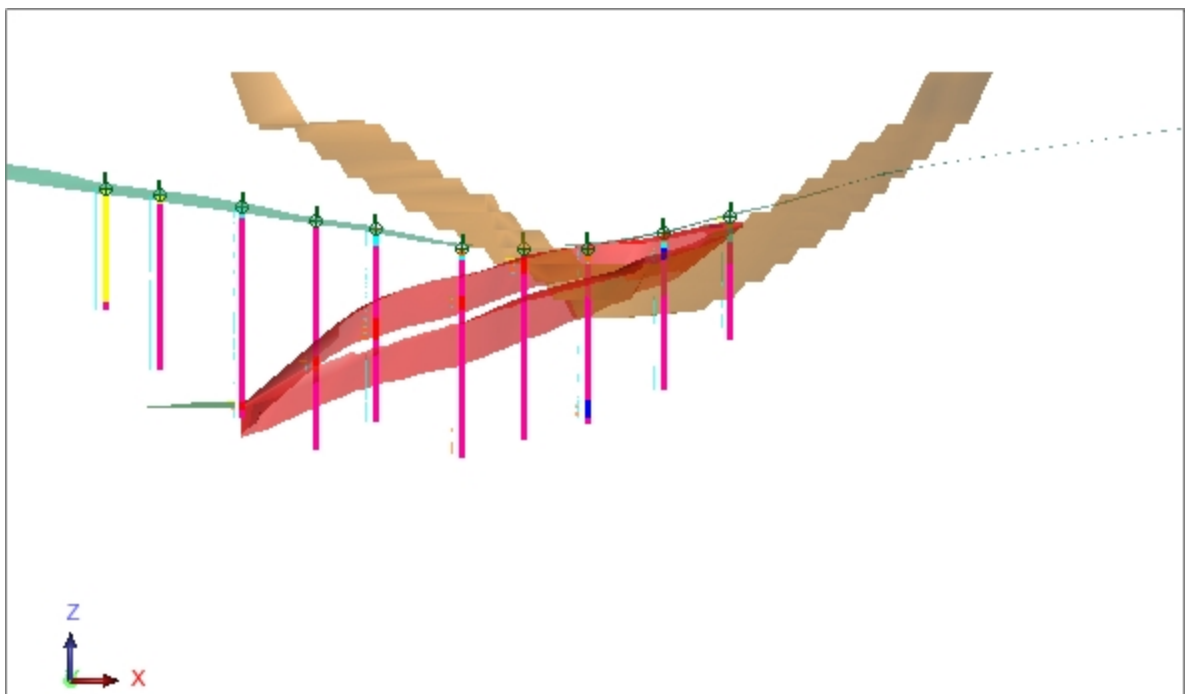

 **Note:** To see all of the steps in this task, run macro **04b_advanced_cross_sectional_viewing.tcl** . You need to **Apply** any forms presented.

Viewing regular sections

Task: View regular sections

1. Click the **Reset graphics** icon .
2. Choose **Display > Drillholes**.
3. Enter the information as shown, and click **Apply**.

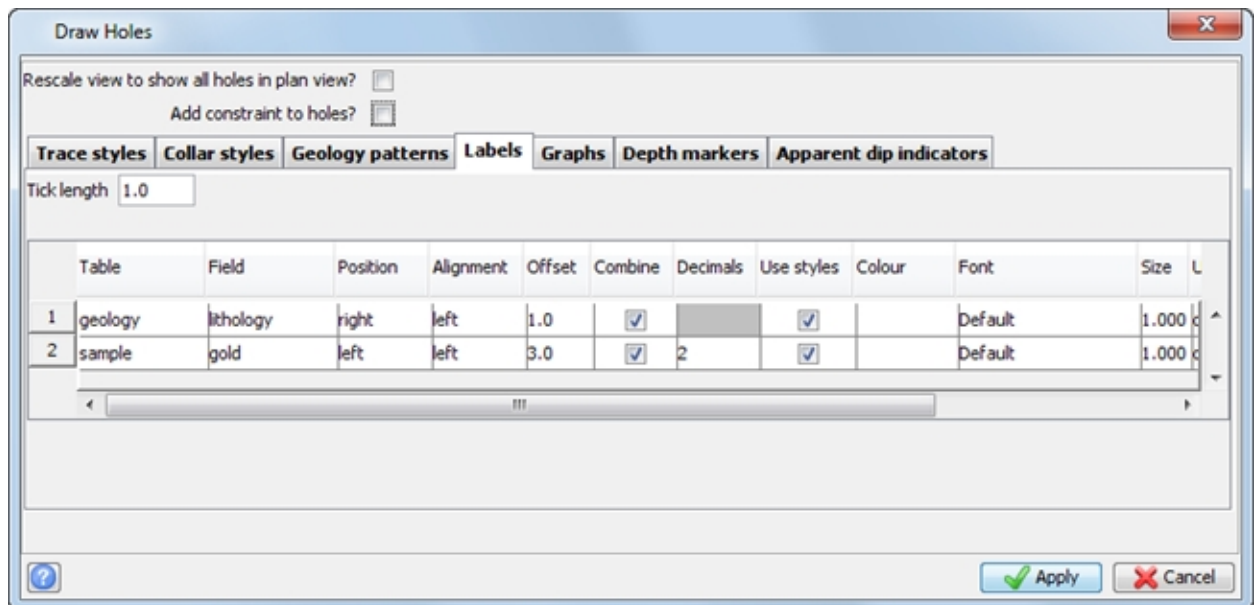

4. In the **Planes** panel, double-click **7120N** in the **crossSection** group.
5. Press F12 to move through each viewing section.

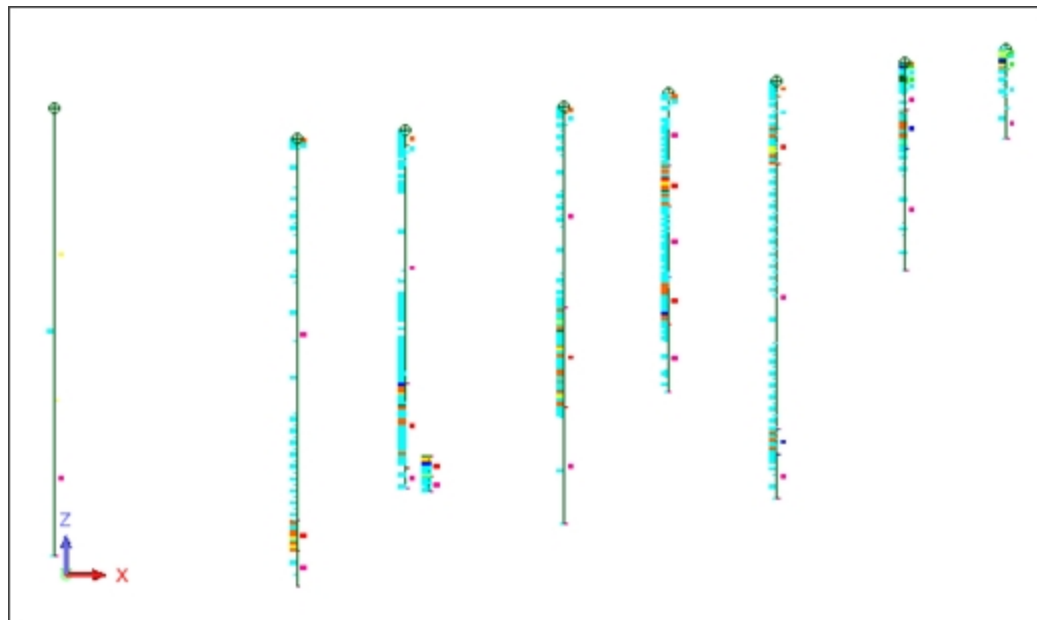

 **Note:** To see all of the steps in this task, run **04c_create_regular_sections.tcl**. You need to **Apply** any forms presented.

Digitising an ore outline

Task: Digitise an ore outline

1. Run macro **04c_create_regular_sections.tcl**.
2. In the **Planes** panel, double-click **7280N** in the **crossSections** group.
3. Zoom in on the area of interest as shown:

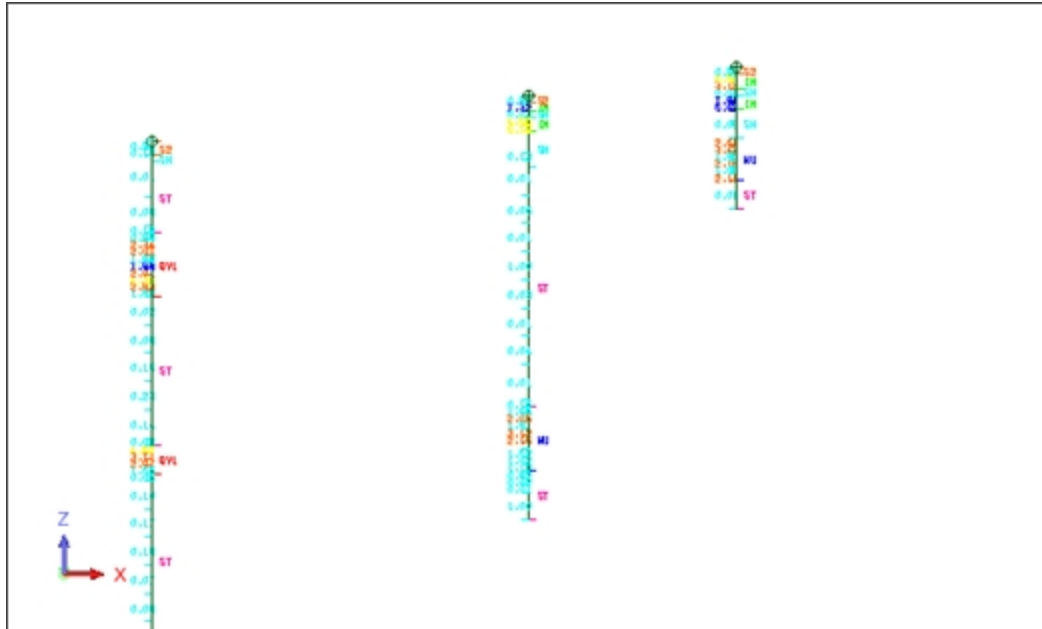

4. Choose **Create > Digitise > Properties**.
5. Enter the information as shown, and click **Apply**.

Digitiser string attributes ✕

String #

Z

Desc

Snapping Properties

Use Desc of selected point
 Project selections to the current plane

User entered Desc

Note: If you select the **Project selections to the current plane** check box, all values will be the same for that section plane, in this case the northing (Y coordinate). If you clear this check box, points that are snapped to drillholes will have the coordinates of that point, while digitised points between holes will snap to the plane of the section.

6. In the **Layers** pane, click **New**.
7. Enter the information as shown, and click **Apply**.
This creates a layer called "**ore_interp**" to store the new data you are digitising.

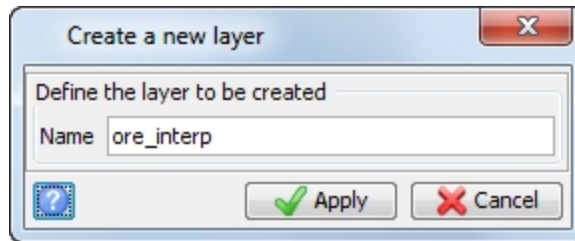

8. Choose **Create > Digitise > New point**.
The following options can be seen under the **Database > Display** menu.

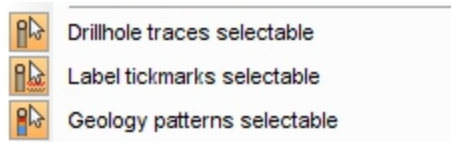

9. Digitise some end points for the ore zone by clicking the points as shown.

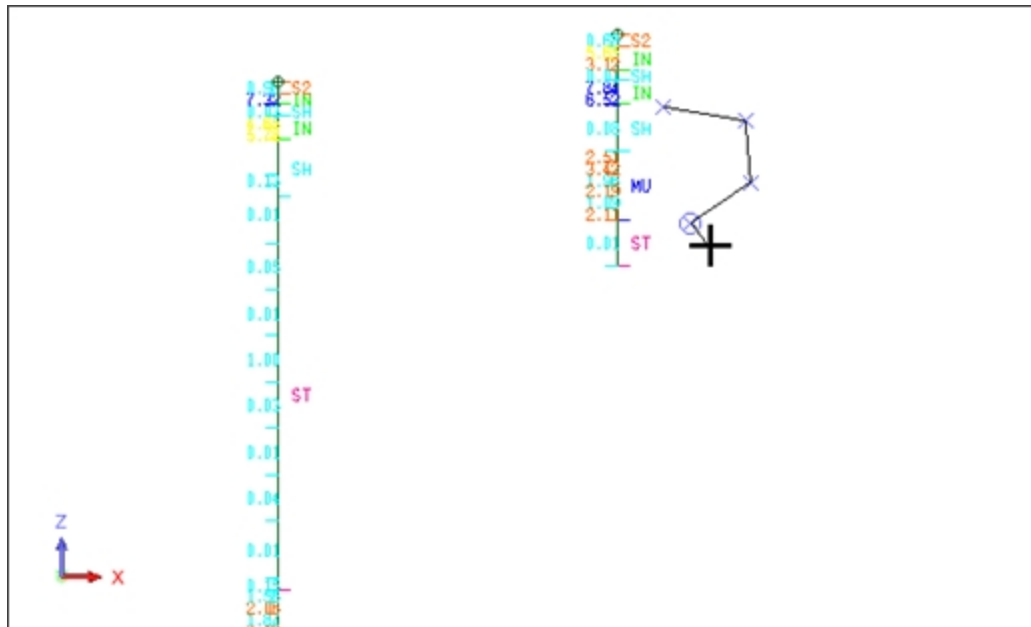

10. Right-click and choose **Point**.
11. Click the drillhole at the lower boundary of the MU zone.

- Click at the lower boundary of the MU zone in the next drillhole as shown.

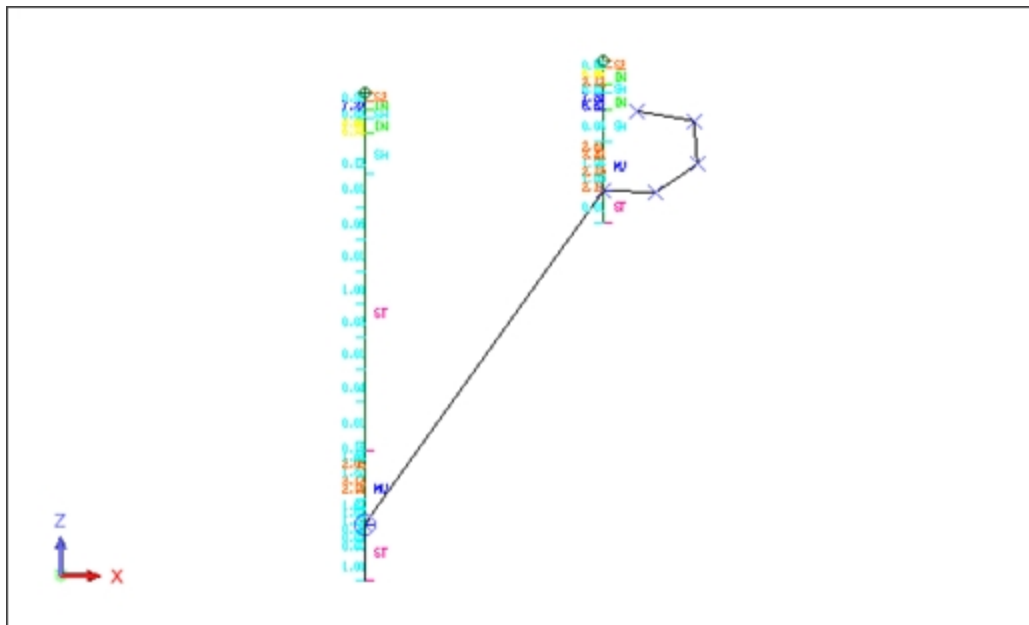

The next two points are generated using the **New midpoint** function. To do this, you need to zoom out so that you can see the next drillhole on the left.

- Zoom or window out to see the area of interest as shown.

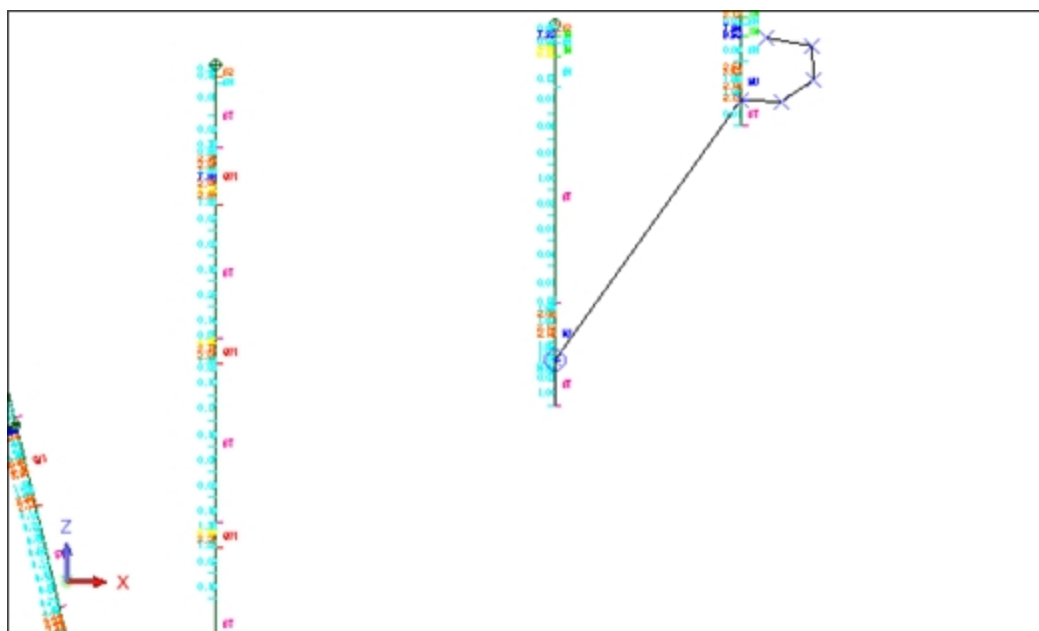

- Right-click and select **New midpoint** .
- Click the point you have just digitised at the bottom of the MU zone on the middle drill-hole.
- Click at the bottom of the drillhole to the left.
A point is created midway between the two selected points.
- Click a point at the top of the ST zone on the left most drillhole.
- Click a point at the top of the MU zone on the middle drillhole.

A point is created midway between the two selected points as shown.

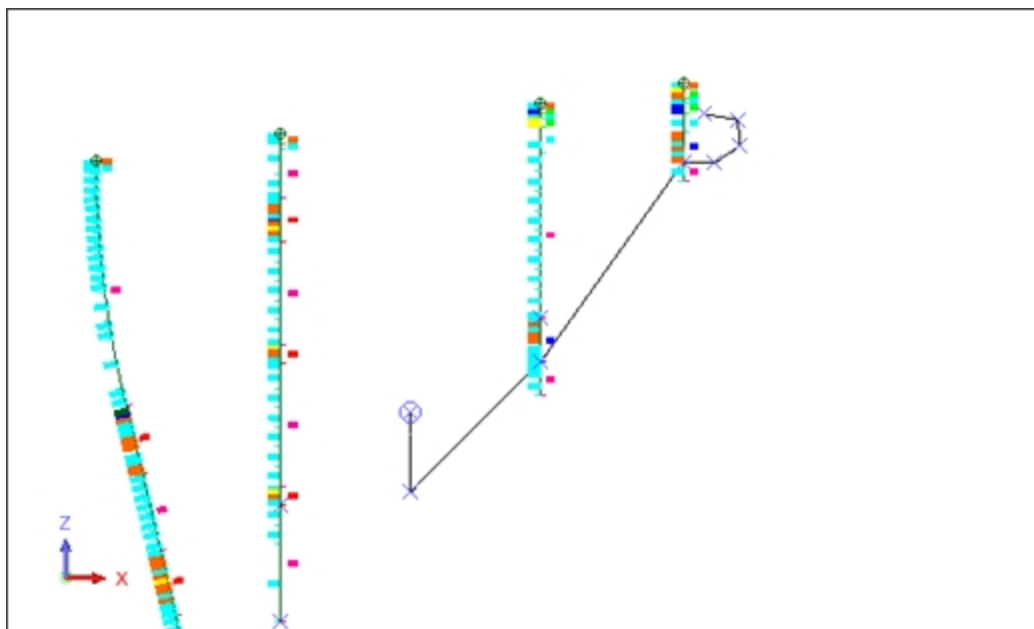

19. Zoom or window out to see the area of interest.

20. Right-click and choose **New point** .

21. Click at the top of the MU zone on the middle drillhole.

22. Click at the top of the MU zone on the right most drillhole.

23. Right-click and choose **Close segment** .

The result will be similar to the following.

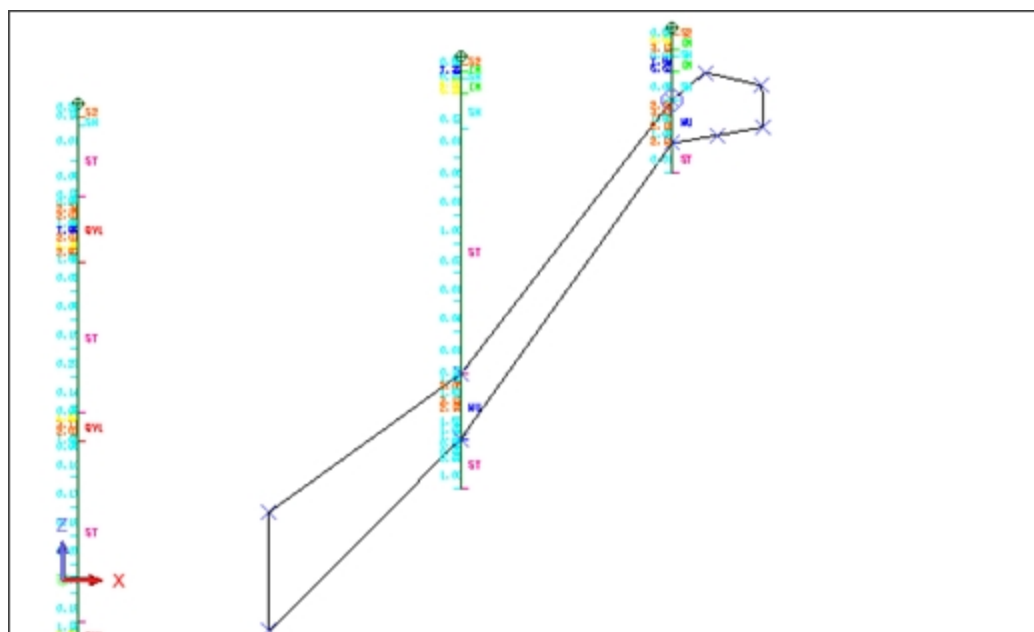

24. Choose **File > Save > string/DTM**.

25. Enter the information as shown, and click **Apply**.

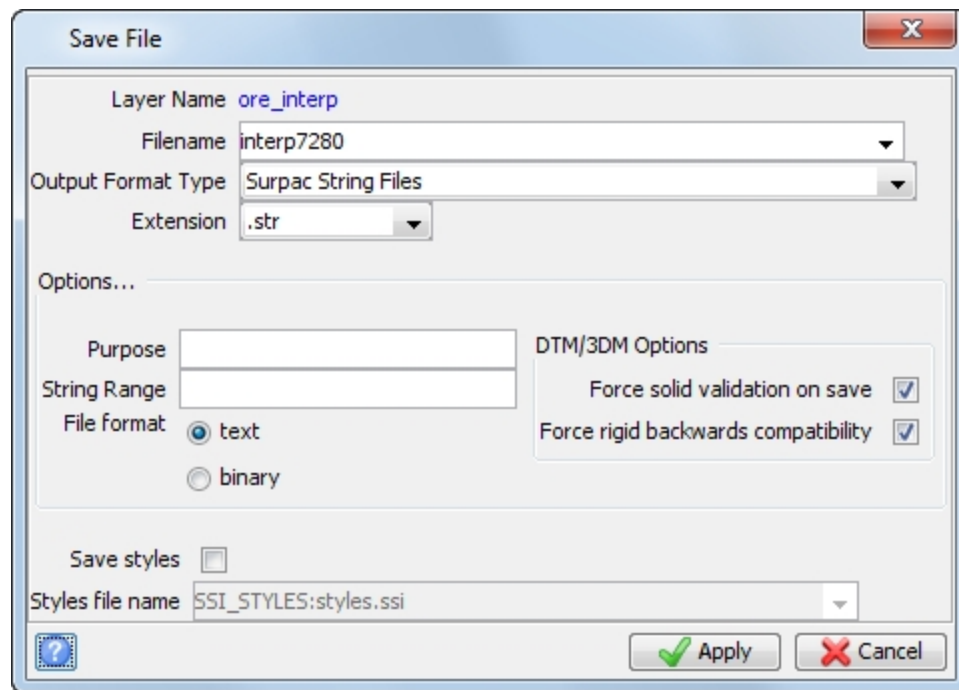

 **Tip:** While it is not necessary to save until the end, it is recommended to save your data throughout the working session.

 **Note:** To see all of the steps in this task, run macro **04d_digitising_ore_outline.tcl**. You need to **Apply** any forms presented.

Flagging an interval table

You will now look at flagging an interval table with 3DM intercepts.

In the previous section, you modelled an ore zone. After modelling an ore zone you might want to carry out some statistical analysis on the data to determine sample populations, to then use the composited data to estimate the block model.

It is good practice to call the table **intersect** and create a new character field called **flag**. This table can then be used to store drillhole intercepts that pass through the 3DM ore envelopes.

Task: Flag an interval table

1. Choose **Database > Administration > Create table**.
2. Enter the information as shown, and click **Apply**.

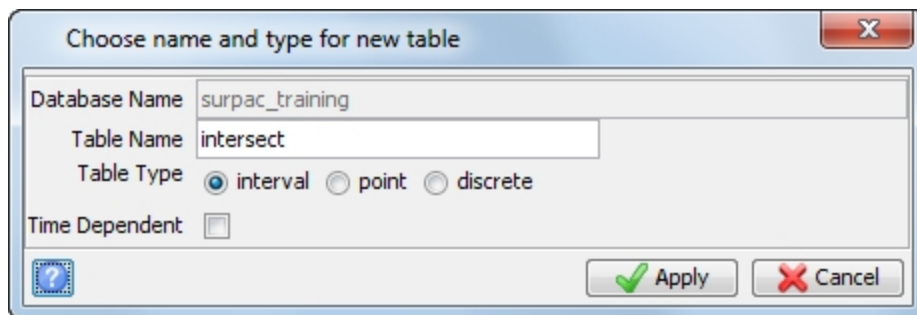

3. Enter the information as shown, and click **Apply**.

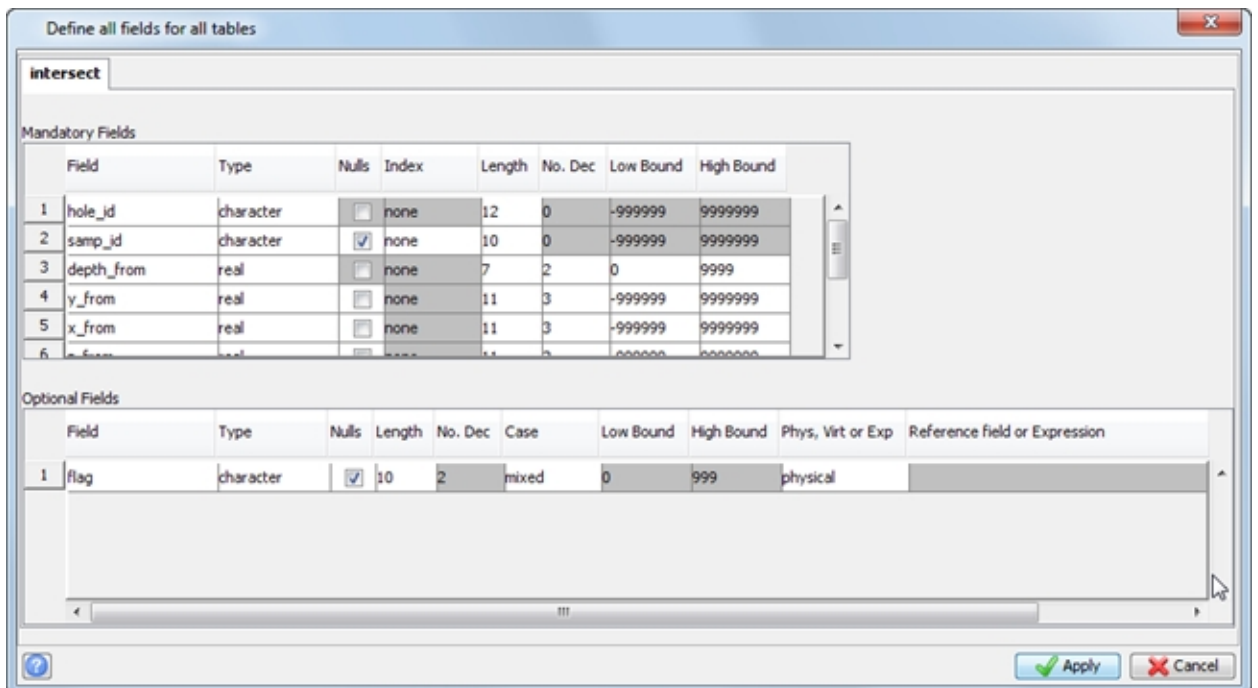

4. Open **ore1.dtm**.

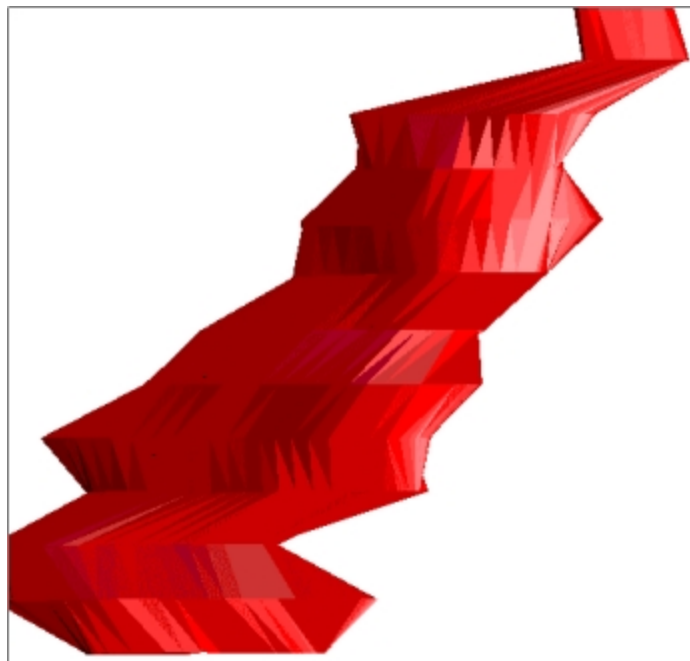

5. Choose **Analysis > Drillhole 3DM intersection**.
 6. Click **Apply** to choose no query constraints.
 7. Enter the information as shown.
 ✎ **Note:** At the top of the form is an object pick list. Surpac lists all objects resident in the active layer. If there is more than one object, you have to intersect each object separately.

- ✎ **Note:** You need to type in the layer name (intersect) on the form.
 Any drill holes that pass through object 8 are written to the **intersect** table.
 A new layer is also created to show the intercepts that pass through the 3DM, as shown in the following image. It is not necessary to save this information. You can use it as a

graphical check to make sure an intercept has been generated for all drillholes passing through the 3DM.

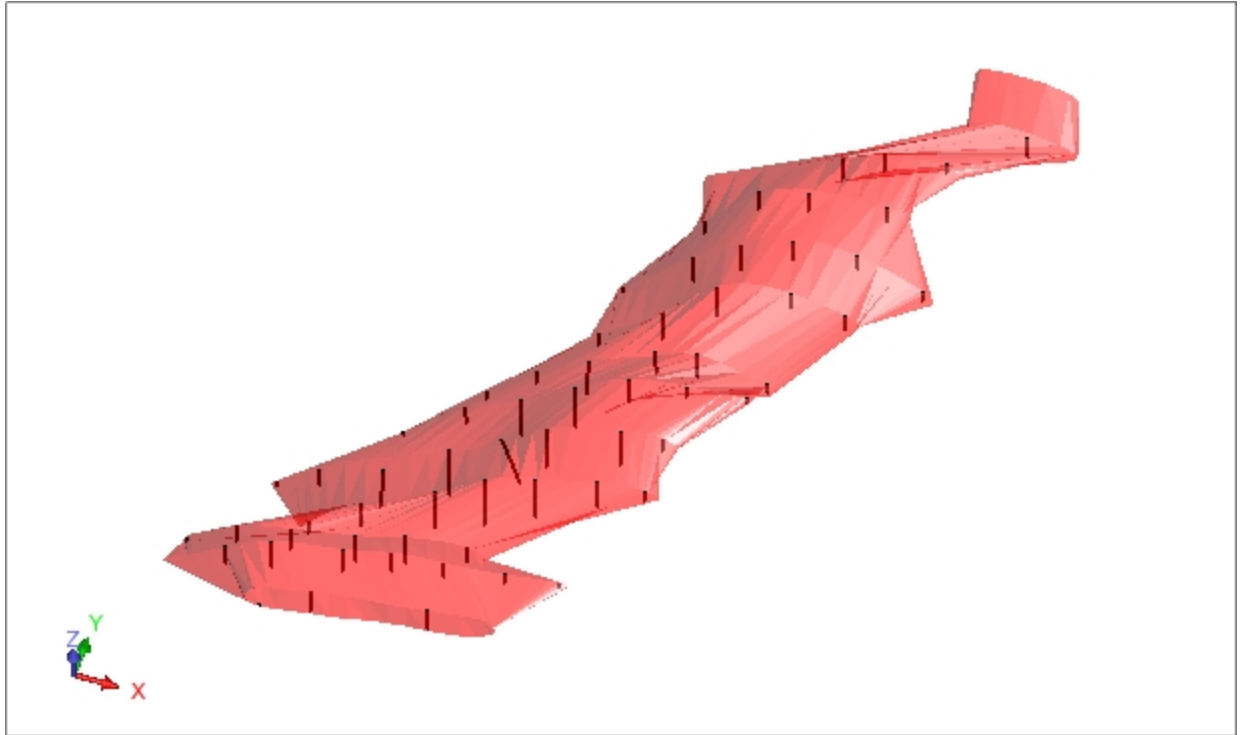

You have now flagged the grade intervals to composite for statistical analysis, compositing, and block model filling.

 **Note:** The new **Intersect** table does not contain any grades, only the locations of the grades in the assay table. It can be used as a defined Zone when you extract composites from the database.

	hole_id	samp_id	depth_from	y_from	x_from	z_from	depth_to	y_to	x_to	z_to	flag
1	WD004		43.39	7362.812	1724.784	162.367	72.60	7364.281	1724.851	133.195	obj1
2	WD005		25.86	7239.180	1643.450	144.382	81.57	7239.180	1643.450	88.672	obj1
3	WD011		88.45	7267.579	1562.928	76.461	122.02	7258.601	1563.223	44.120	obj1
4	WD016		90.04	7325.668	1600.711	88.200	116.60	7329.798	1601.410	61.997	obj1
5	WD031		16.48	7160.389	1568.655	138.520	43.54	7160.332	1568.658	111.460	obj1
6	WD032		48.74	7282.290	1642.095	129.889	101.35	7284.944	1654.081	78.732	obj1
7	WD033		100.14	7398.995	1672.924	106.996	114.69	7398.886	1672.558	92.451	obj1
8	WD095		4.51	7438.872	1797.591	222.275	28.71	7439.153	1797.601	198.077	obj1
9	WRC001		29.56	7318.770	1682.686	161.922	80.33	7318.770	1682.686	111.152	obj1
10	WRC002		58.87	7399.570	1717.718	152.964	92.41	7399.570	1717.718	119.424	obj1
11	WRC003		1.22	7318.770	1761.158	199.937	14.35	7318.770	1761.158	186.807	obj1
12	WRC006		0.69	7523.068	1878.866	235.529	14.03	7523.068	1878.866	222.189	obj1
13	WRC007		125.73	7360.275	1605.616	60.398	136.75	7360.275	1605.616	49.378	obj1
14	WRC008		63.87	7357.831	1678.763	134.921	99.83	7354.659	1679.080	99.113	obj1
15	WRC009		48.99	7437.462	1727.527	171.396	79.74	7437.462	1727.527	140.646	obj1
16	WRC010		68.65	7281.089	1605.175	102.105	124.17	7281.089	1605.175	46.585	obj1
17	WRC012		102.43	7201.499	1479.500	65.143	122.16	7201.499	1479.500	45.413	obj1
18	WRC013		32.31	7524.472	1804.598	205.113	60.12	7524.472	1804.598	177.303	obj1
19	WRC014		84.71	7240.180	1555.169	73.131	114.75	7240.180	1555.169	43.091	obj1
20	WRC015		59.65	7200.096	1564.978	95.350	91.85	7200.096	1564.978	63.150	obj1
21	WRC017		56.75	7119.489	1522.939	110.819	61.13	7119.489	1522.939	106.439	obj1
22	WRC019		112.28	7160.591	1443.066	65.947	114.58	7160.591	1443.066	63.647	obj1
23	WRC020		40.61	7159.591	1518.736	125.434	72.46	7159.591	1518.736	93.584	obj1
24	WRC021		26.52	7480.967	1759.018	202.958	47.10	7480.967	1759.018	182.378	obj1
25	WRC022		0.66	7479.563	1851.503	230.214	18.73	7479.563	1851.503	212.144	obj1
26	WRC023		17.29	7402.377	1846.636	207.464	35.64	7402.377	1846.636	189.114	obj1

8. Close the database.

 **Note:** To see all of the steps in this task, run the macro **04e_create_flag_table.tcl**. You need to **Apply** any forms presented. You need to use **Edit > View table** after running the macro to see the Intersect data.

Determining the grade of a digitised segment

When a segment has been digitised on a section, the grade for that segment can be calculated using the **Digitised segment grade** function.

Task: Determine the grade of a digitised segment

1. Open **section_7320_north.swa**.

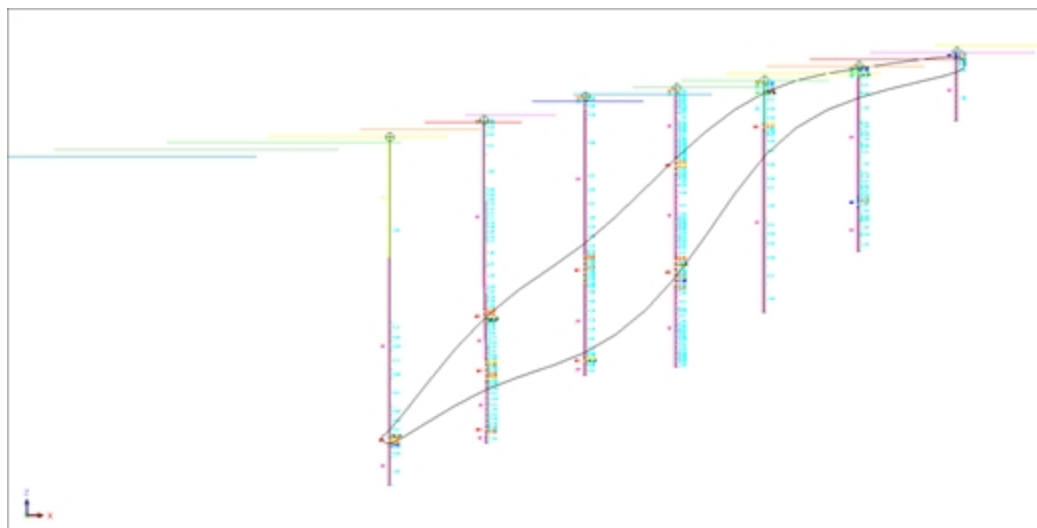

2. Choose **Sections > Digitised segment grade**.
3. Enter the information as shown, and click **Apply**.

Digitised Segment Grade

Database

Composite method length weighted

Minimum % of sample to be included 75

	Table	Field	Dilute	D Field
1	sample	gold	<input checked="" type="checkbox"/>	D1

Apply Cancel

4. Click the segment.
The results are displayed in the **message window**.

```
Digitised Segment Grade:
String number = 1
Segment number = 6
Segment area = 7216.43
gold (sample) = 1.848
```

5. Press ESC.
6. Choose **Inquire > Point properties** and click any point on the segment.

The point properties are displayed in the **message window**. The segment grade is written in the D1 field.

```
Layer=ore1.str String=1 Segment=6 Point=2 Y=7320 X=1587.061 Z=78.936  
Desc=1.84804
```

7. Press ESC.
8. Close the database.

 **Note:** To see all of the steps in this section, run macro **04f_determine_segment_grade.tcl**. You will need to click **Apply** on any forms presented.

Section plotting

Creating a simple section plot

Task: Create a simple section plot

1. Open **topo1.str** in **Graphics**.
2. Open **ore1.str** in **Graphics**.
3. Connect to **surpac_training.ddb**.
4. Choose **Display > Drillholes**.
5. Enter the information as shown, and click **Apply**.

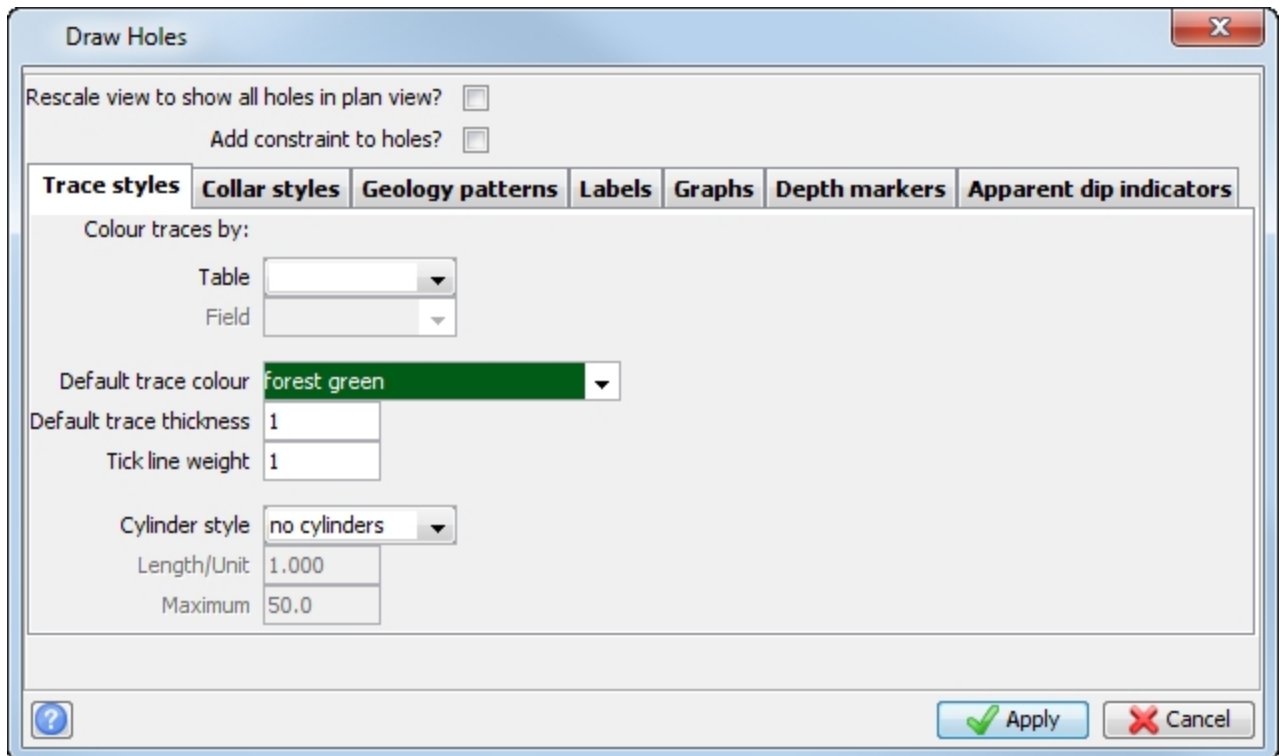

6. Enter the information as shown, and click **Apply**.

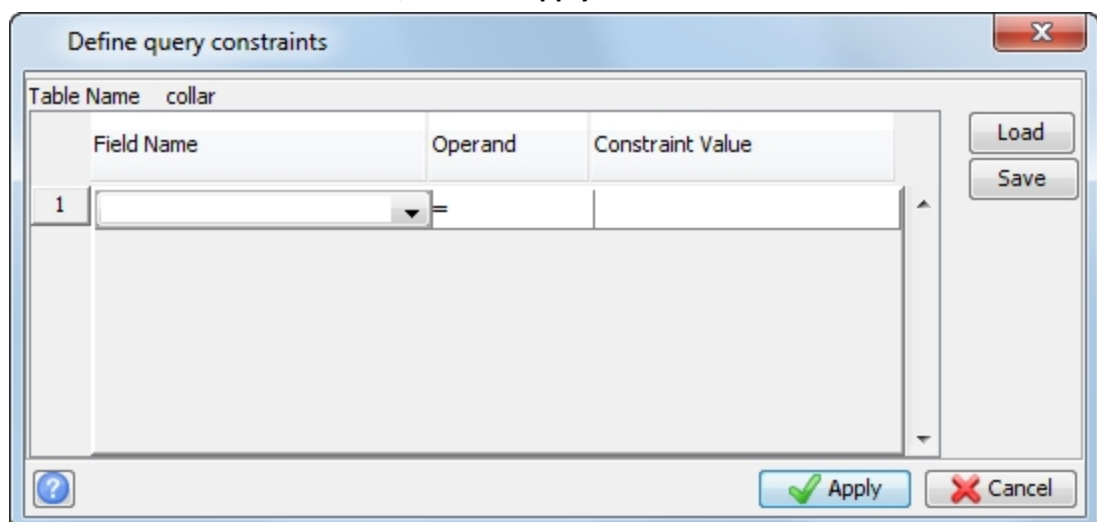

The data in the two string files and the drillhole traces are displayed.

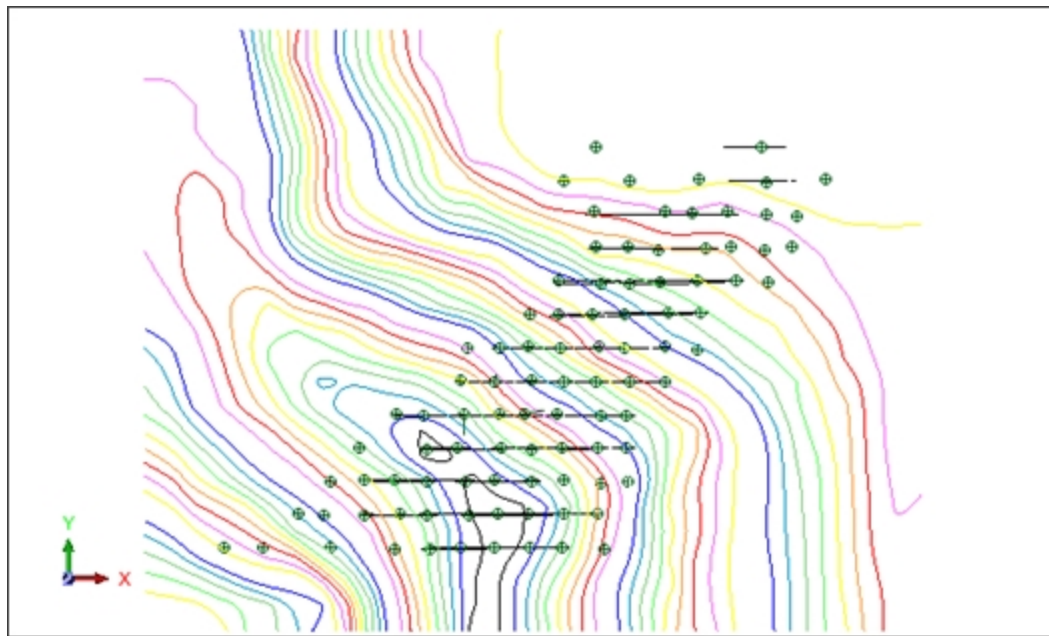

7. Choose **Display > Drillholes**.
8. Enter the information as shown on the **Geology patterns** tab.

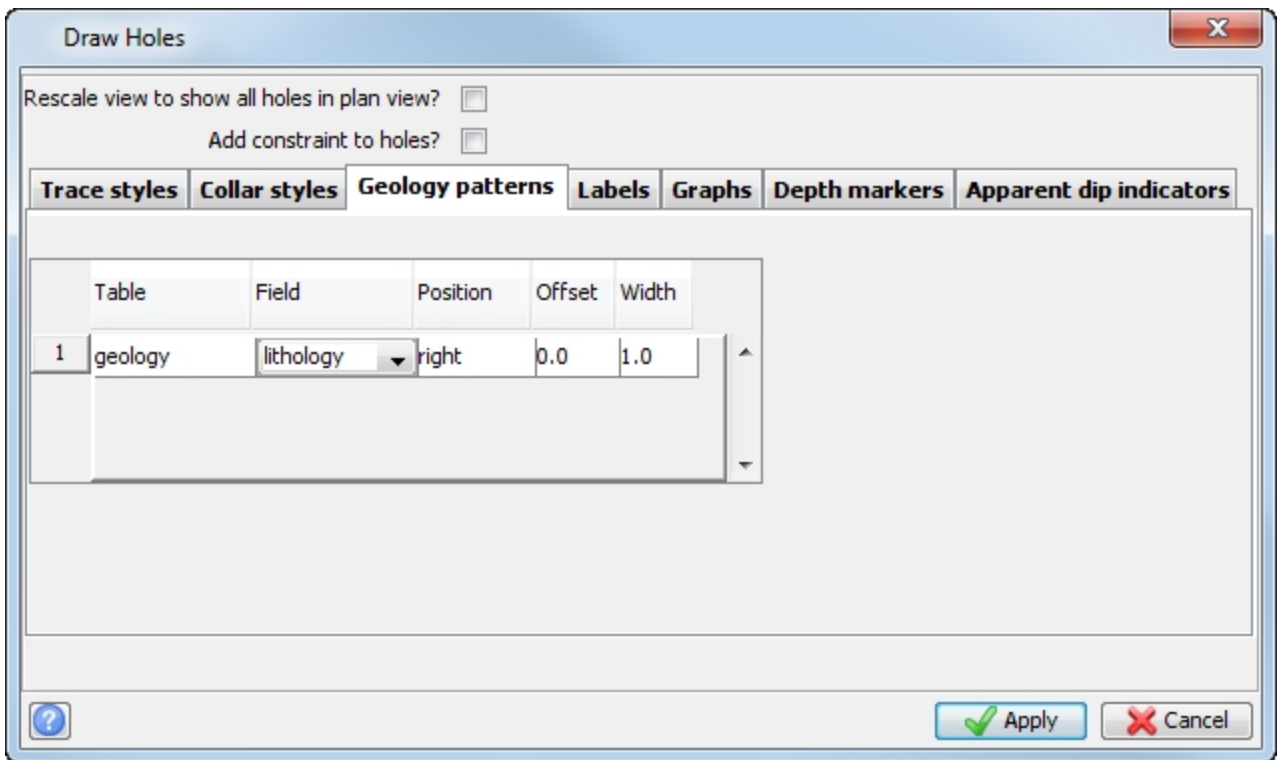

9. Enter the information as shown on the **Labels** tab, and click **Apply**.

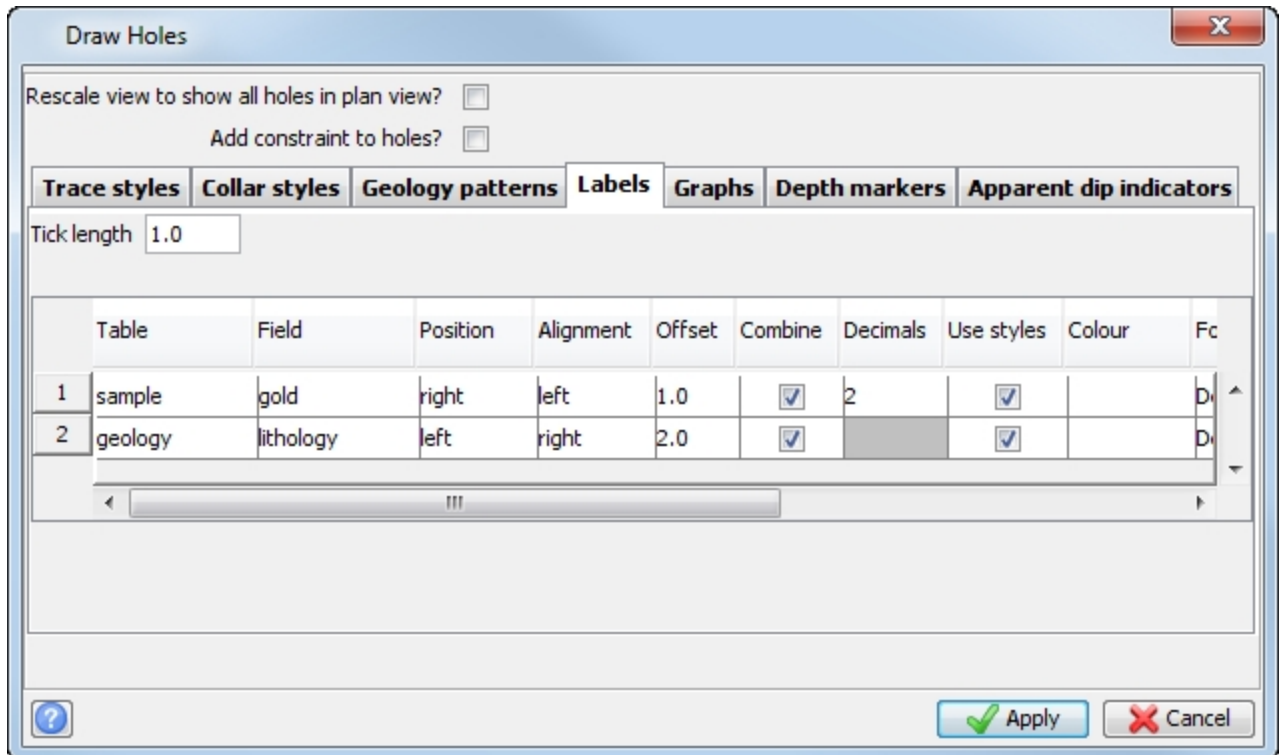

Note: To add a second row to the table, right-click in the empty space below the first row and select **Add**.

10. Click **Section view**.
The data is displayed as shown.

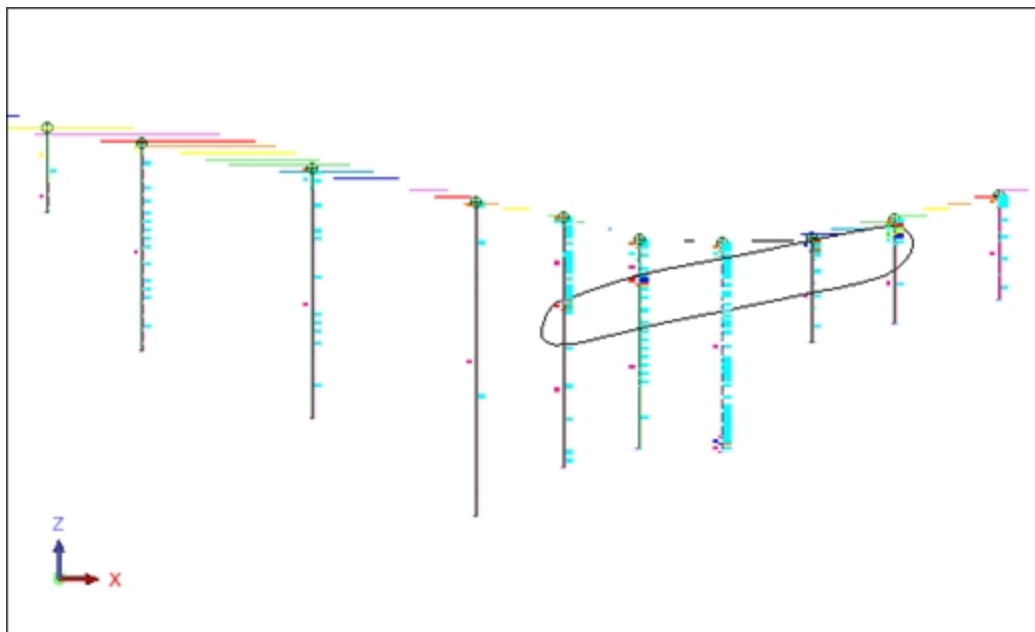

The plane name is displayed in the Status bar.

11. In the **Planes** panel, double-click **7320N** in the **crossSections** group.

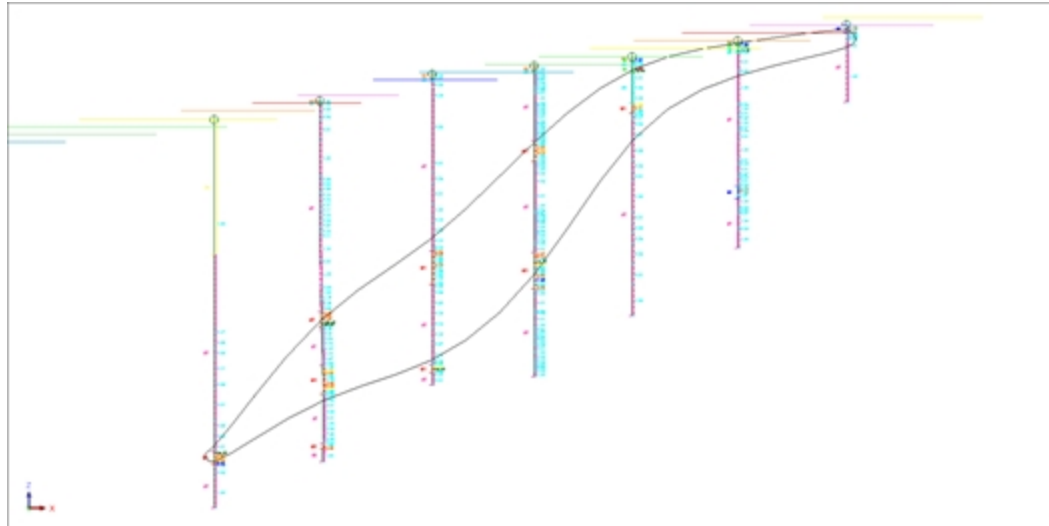

12. Click **Autoplot** .
13. Enter the information as shown, and click **Apply**.

Autoplot presentation parameters

Main | **Legends**

Sheet setup

Output file name:

Sheet size:

Orientation: Landscape Portrait

Data units: Metric Imperial

Scale method: Fit to Screen
 Manual Scale
 Selection Box

Auto-group Elements:

Manual scale options

Minimum scale to fit data in window: **2179**

Lock X/Y scale:

Scale:

Y scale:

Lower left corner coordinate

E:

Z:

Plot content

Drawing area:

Grid:

Border:

Title block:

Plot data contents

Vector data, no surfaces
 Raster data, render surfaces

Raster resolution (DPI):

Optional content

Note file: **Plan strip - off** **Batch sections - off**

Include note file:

14. Enter the information as shown, and click **Apply**.

User definable title block lines

Title Line 1	Drill Hole Section
Title Line 2	7320 North
Title Line 3	

Apply Cancel

15. Press F1.

16. Click and drag in **Graphics** to move the box as shown.

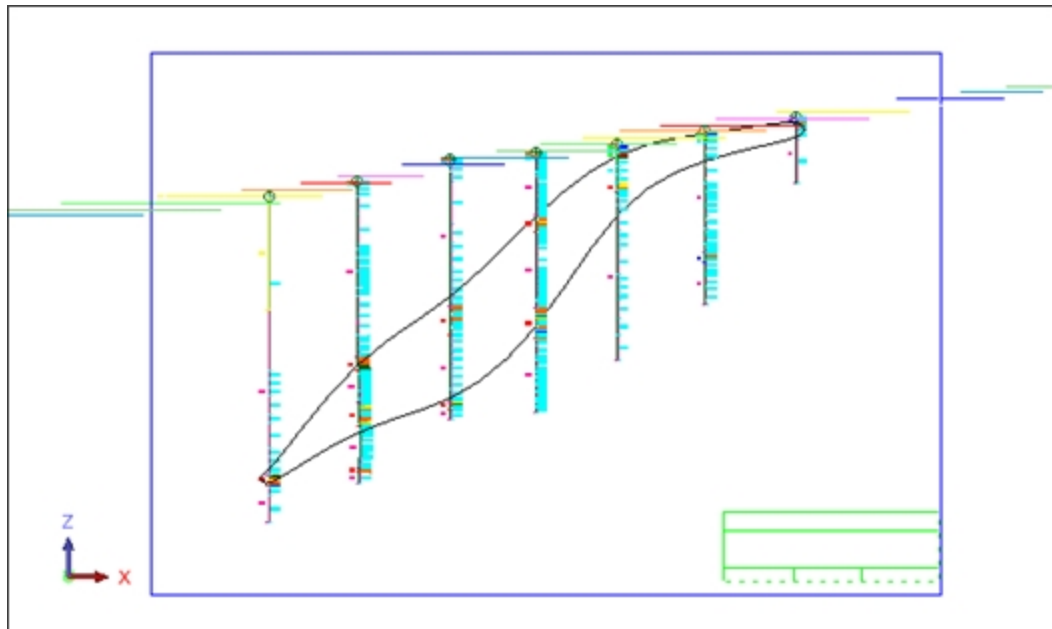

17. Press F2.

18. Enter the information as shown, and click **Apply**.

Grid line spacing and grid style

	Y Grid Lines	X Grid Lines
Interval	50	100
Type	<input checked="" type="radio"/> full lines <input type="radio"/> border ticks <input type="radio"/> grid crosses	<input checked="" type="radio"/> full lines <input type="radio"/> border ticks <input type="radio"/> grid crosses

Apply Cancel

The file **section.dwf** is created and displayed in the **Plot Preview** window.

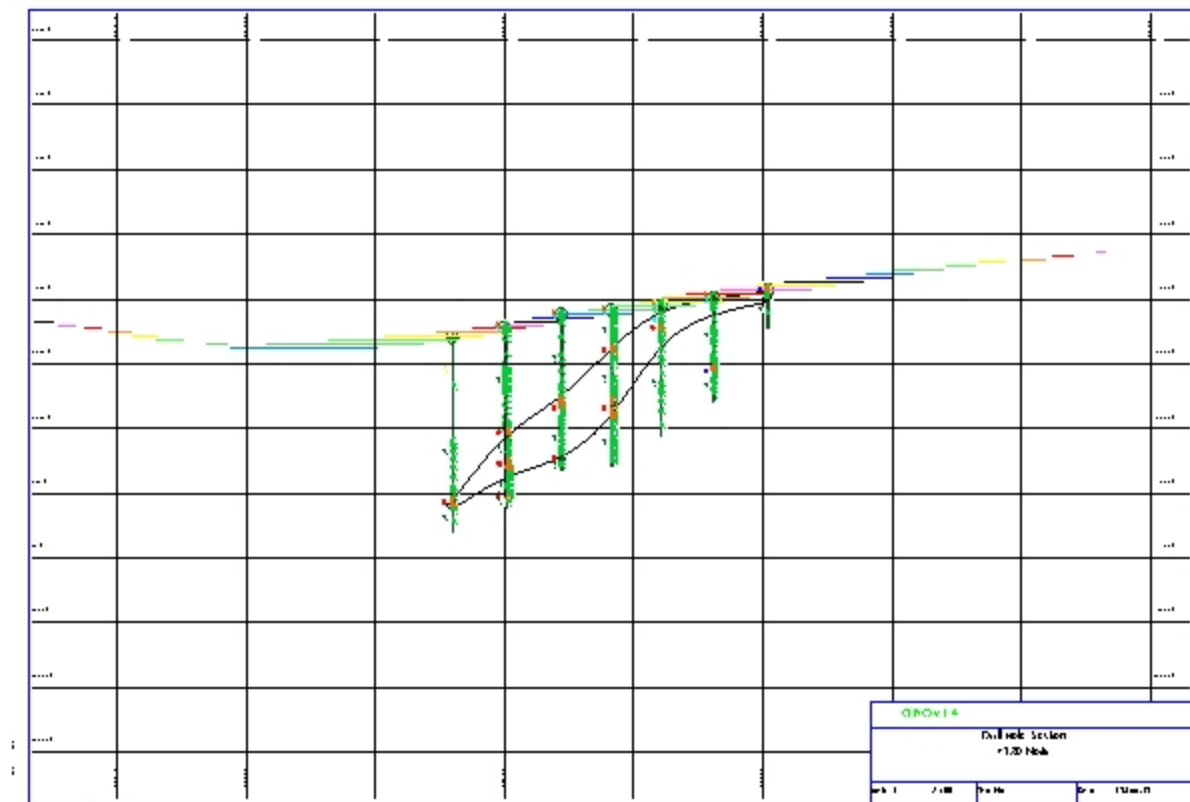

19. Choose **File > Close** to close the **Plot Preview** window.

 **Note:** To see all of the steps in this task, run **05a_autoplot_section.tcl**, You need to click **Apply** on any forms presented.

Creating a section plot with a plan strip

Task: Create a section plot with a plan strip

1. Click **Autoplot** .
2. Enter the information as shown, and click **Apply**.

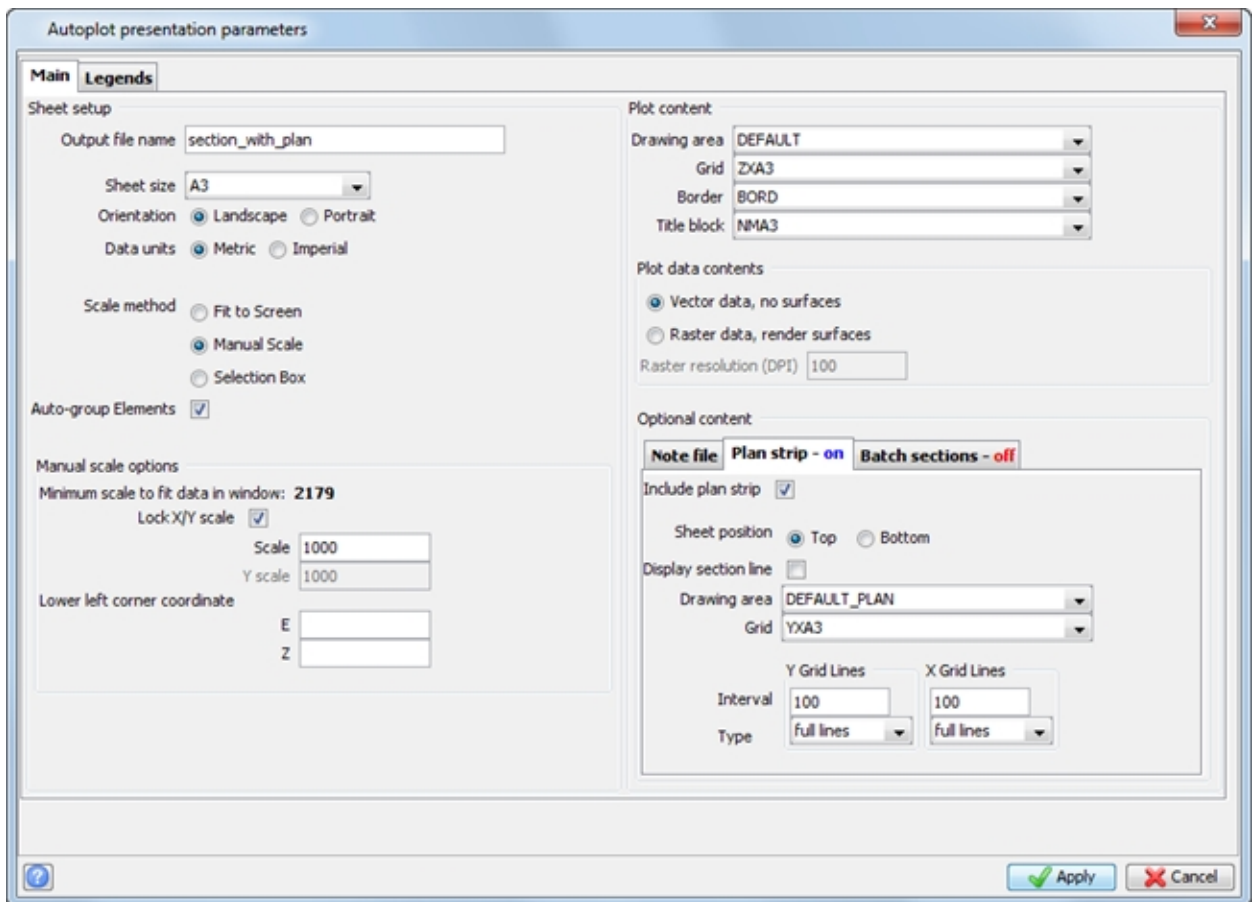

3. Enter the information as shown, and then click **Apply**.

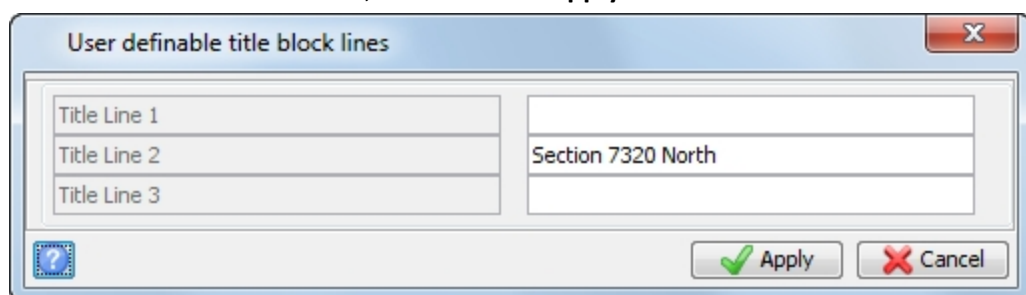

4. Press F1.

- Click and drag in **Graphics** to move the box.

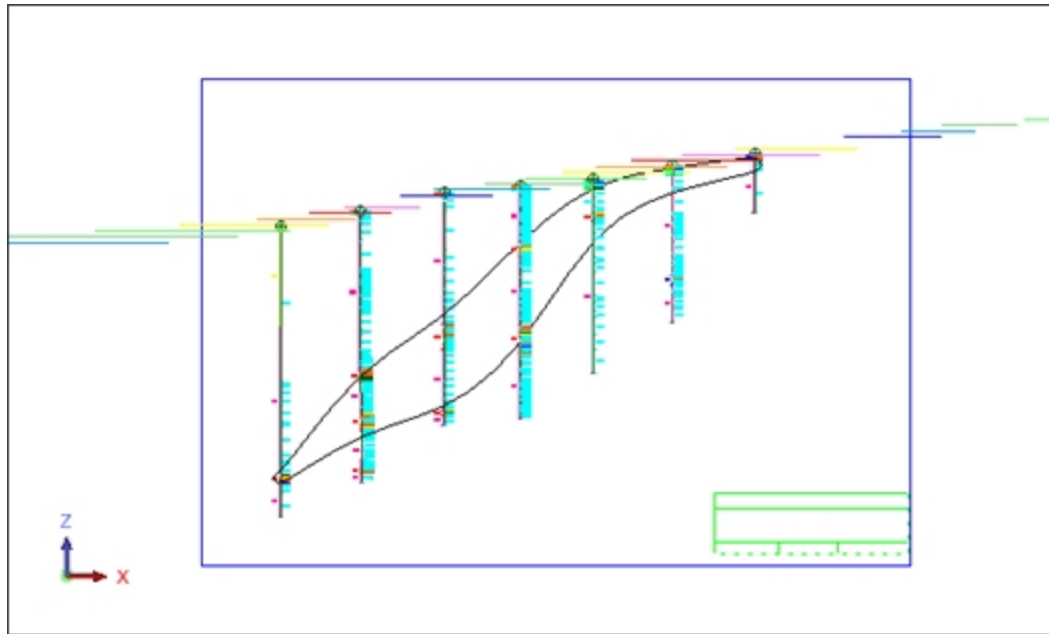

- Press F2.
- Enter the information as shown, and click **Apply**.

Grid line spacing and grid style

Interval	Y Grid Lines 50	X Grid Lines 100
Type	<input checked="" type="radio"/> full lines <input type="radio"/> border ticks <input type="radio"/> grid crosses	<input checked="" type="radio"/> full lines <input type="radio"/> border ticks <input type="radio"/> grid crosses

The file **section_with_plan.dwf** is created and displayed in the **Plot Preview** window, as shown.

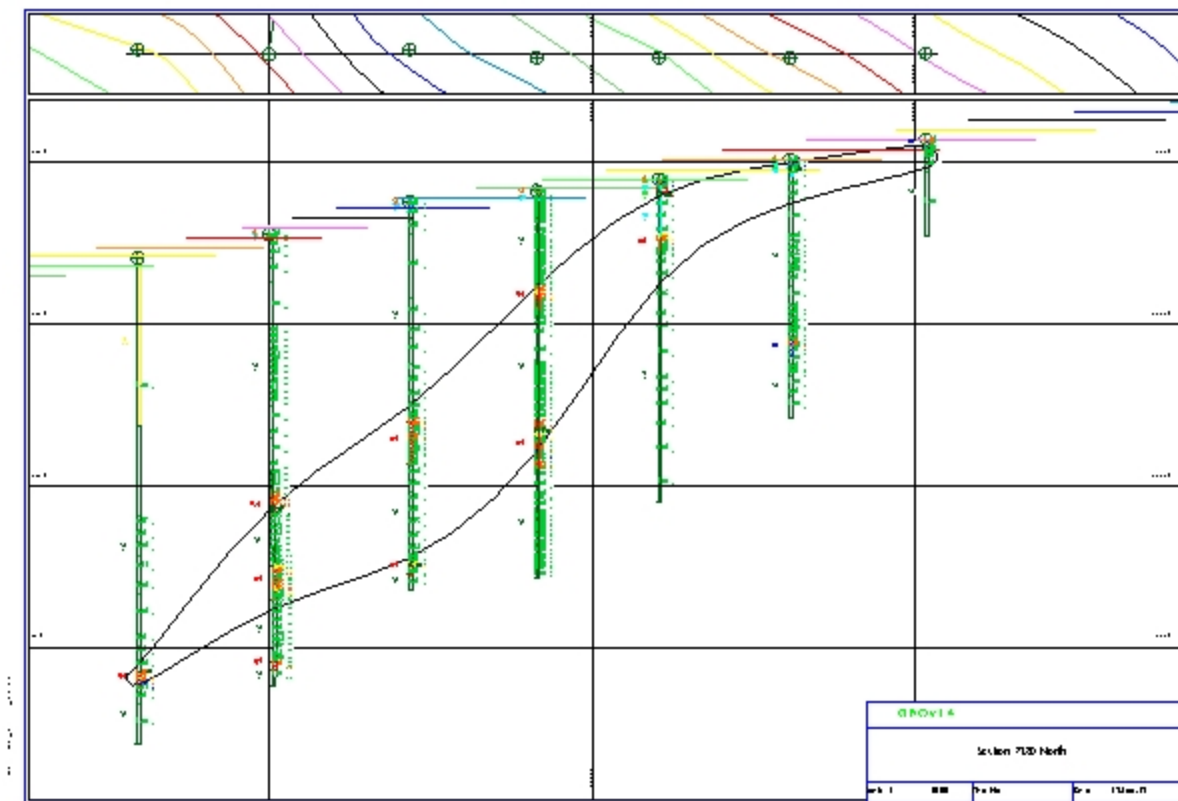

8. Choose **File > Close** to close the **Plot Preview** window.

Note: To see all of the steps in this section, run **05b_autoplot_section_plan_strip.tcl**. You need to click **Apply** on any forms presented.

Creating and plotting oblique sections of drillhole data

Task: Create and plot an oblique section of drillhole data

1. Click **Reset graphics** .
2. Open **oblique_section_line.swa**.
3. Choose **Display > Point > Attributes**.
4. Enter the information as shown, and click **Apply**.

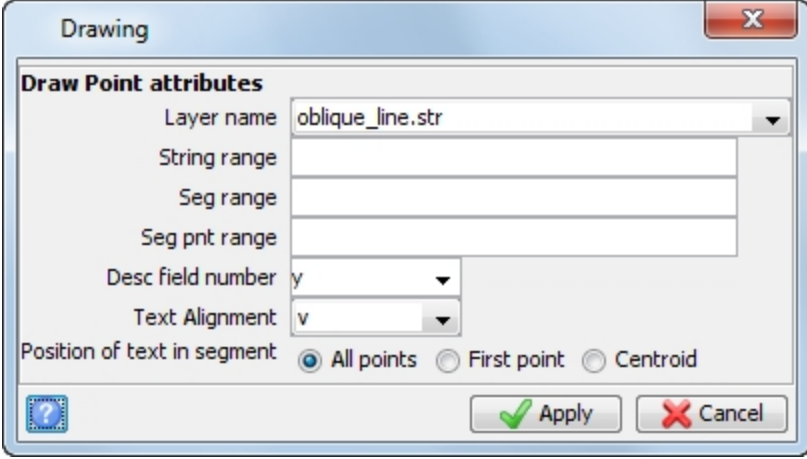

The screenshot shows the 'Drawing' dialog box with the 'Draw Point attributes' section. The 'Layer name' is set to 'oblique_line.str'. The 'String range', 'Seg range', and 'Seg pnt range' fields are empty. The 'Desc field number' is set to 'y' and 'Text Alignment' is set to 'v'. The 'Position of text in segment' radio buttons are set to 'All points'. The 'Apply' button is highlighted.

5. Choose **Display > Point > Attributes**.
6. Enter the information as shown, and click **Apply**.

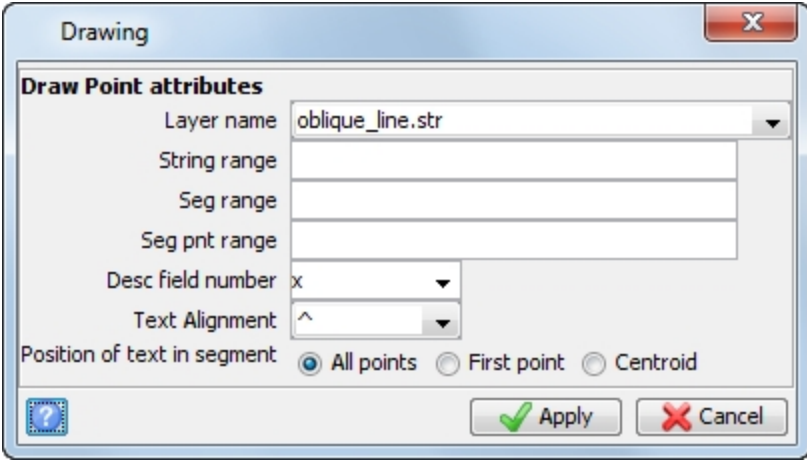

The screenshot shows the 'Drawing' dialog box with the 'Draw Point attributes' section. The 'Layer name' is set to 'oblique_line.str'. The 'String range', 'Seg range', and 'Seg pnt range' fields are empty. The 'Desc field number' is set to 'x' and 'Text Alignment' is set to '^'. The 'Position of text in segment' radio buttons are set to 'All points'. The 'Apply' button is highlighted.

7. Choose **Extract > Sections for plotting**.

8. Enter the information as shown, and then click **Apply**.

9. Enter the information as shown, and then click **Apply**.

Field Name	Class Range	Treat negatives	Bulking Threshold	Decimals	Graphs	Graph Location	Length per Unit	Maximum Value
1 gold	0,10,2,999	as nulls	0	2	none			

10. Enter the information as shown, and click **Apply**.

Define geology fields

Table geology

Combine adjacent samples

Define the geology fields and their plotting characteristics

	Field Name	Geology Location	Box Size
1	rock	left	5

Apply Cancel

11. Enter the information as shown, and click **Apply**.

Define query constraints

Table Name collar

	Field Name	Operand	Constraint Value
1		=	

Load Save

Apply Cancel

The file **oblique_section0.str** is created in the working directory.

12. Click **Reset graphics** .
13. Open **oblique_section0.str** in **Graphics**.
14. Choose **Display > Strings > With string numbers**.

15. Enter the information as shown, and click **Apply**.

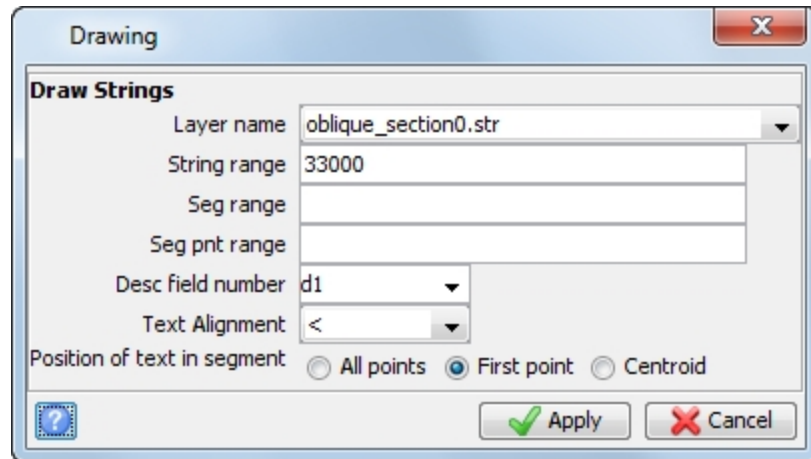

String 33 000 is displayed.

16. Choose **Inquire > Point properties**.

17. Select string 33 000.

The point properties of string 33 00 are displayed in the **message window**.

Note: String 33000 is created only when an oblique section is defined. This string consists of a single point, which contains the start and end coordinates of the oblique section in the description fields of the point.

18. Choose **Plotting > Map > Import**.

19. Enter the information as shown, and click **Apply**.

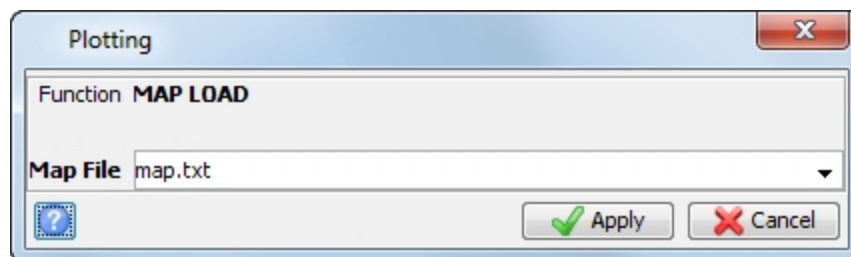

The **map_load.log** file is displayed in your default text editor.

```
Map load log
=====
Loaded LEGEND
Loaded OBLIQUE DH SECTION
Loaded PLAN VIEW
Loaded SECTION VIEW
```

20. Choose **Plotting > Map > Edit**.

21. Enter the information as shown, and click **Apply**.

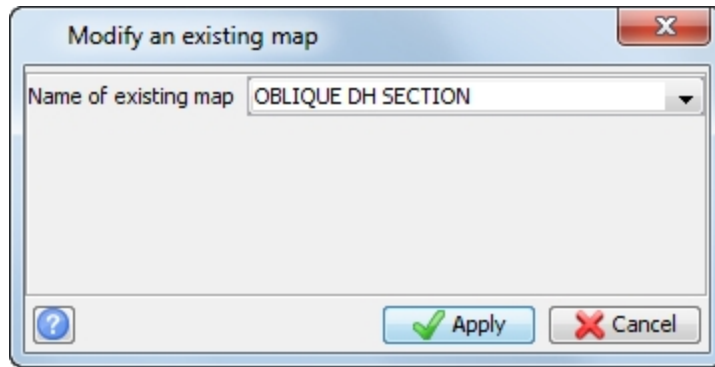

22. Enter the information as shown, and click **Apply**.

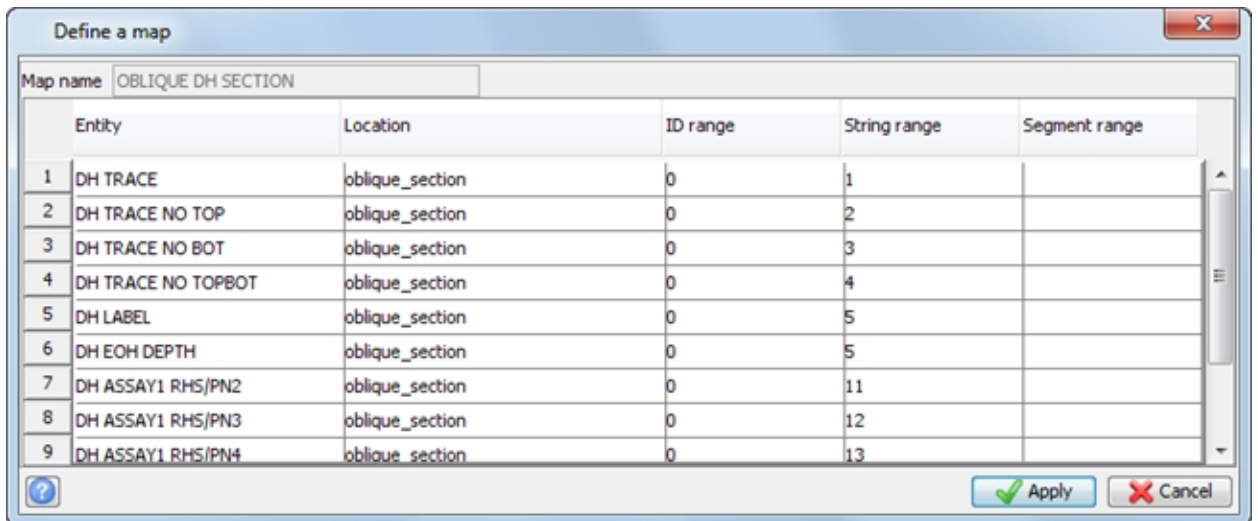

23. Choose **Plotting > Process > Map**.

24. Enter the information as shown, and click **Apply**.

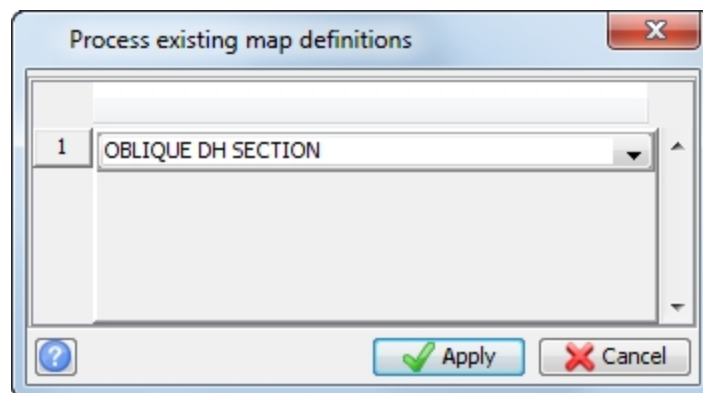

25. On the **Plot Parameters** tab, enter the information as shown, and then select the **Oblique Section Grid** tab.

Plot presentation parameters

Map name: **OBLIQUE DH SECTION**
 Output file name: oblique_dh_section

Plot Parameters **Oblique Section Grid**

Scale options
 Minimum scale to fit data: **1489**
 Lock X/Y scale
 Scale: 2000

Data extents

	Y	X
Minimum	5.00	2.66
Maximum	237.03	535.88

Sheet setup and orientation characteristics

Sheet size: A3
 Border: BORD
 Drawing area: DRAW
 Grid: OBA3
 Title block: NMA3

Plot orientation

Landscape Centred Landscape Fixed
 Portrait Centred Portrait Fixed
 Rotate About Point Rotate About Centroid

Quadrant North-West North-East
 South-West South-East

Data units Metric Imperial

Miscellaneous options

Overprint
 Text rotation
 Display plot after processing

26. On the **Oblique Section Grid** tab, enter the information as shown, and then click **Apply**.
✍ **Note:** The fields of this tab only become active if the **Grid** selected on the **Plot Parameters** tab is blank, NOGR, or one of the oblique grids.

The screenshot shows a dialog box titled "Plot presentation parameters" with a close button (X) in the top right corner. The "Map name" is "OBLIQUE DH SECTION" and the "Output file name" is "oblique_dh_section". There are two tabs: "Plot Parameters" and "Oblique Section Grid", with the latter being active. Under the "Oblique Section Grid" tab, the "Plot Northing and Easting grid lines" checkbox is checked. The "Section file" dropdown is set to "oblique_section0.str", the "Section line string number" is "33000", and the "Grid" dropdown is set to "OBLIQUE SECTION TWO LABELS". Below these are two columns of settings for "Northing Grid Lines" and "Easting Grid Lines". Each column has a "Type" section with three radio button options: "full lines", "border ticks" (which is selected), and "no lines". Below the "Type" section is an "Interval" input field set to "100". At the bottom left is a help icon (question mark in a square), and at the bottom right are "Apply" and "Cancel" buttons.

27. Enter the information as shown, and click **Apply**.

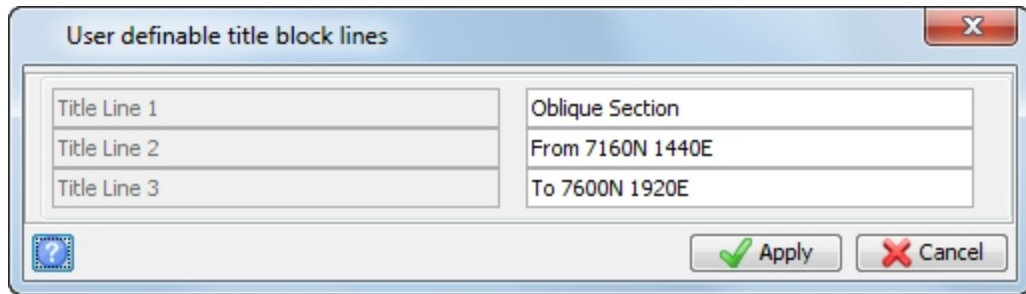

28. Enter the information as shown, and click **Apply**.

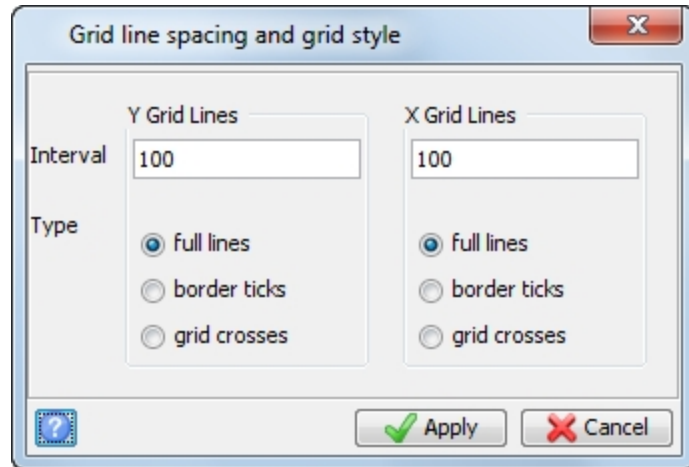

The **Plotting** window opens, and the **.dwf** file is displayed.

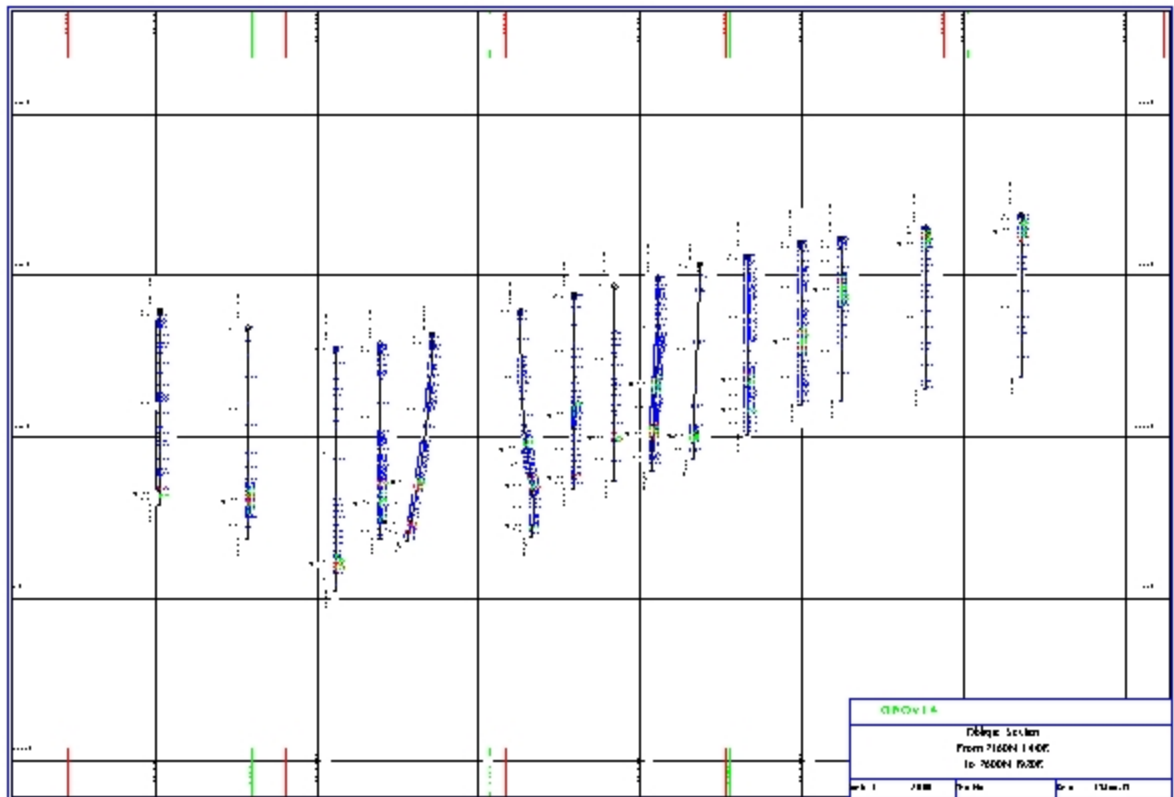

29. Select **View > Window in**, or use the mouse scroll wheel to zoom in on one edge of the map.

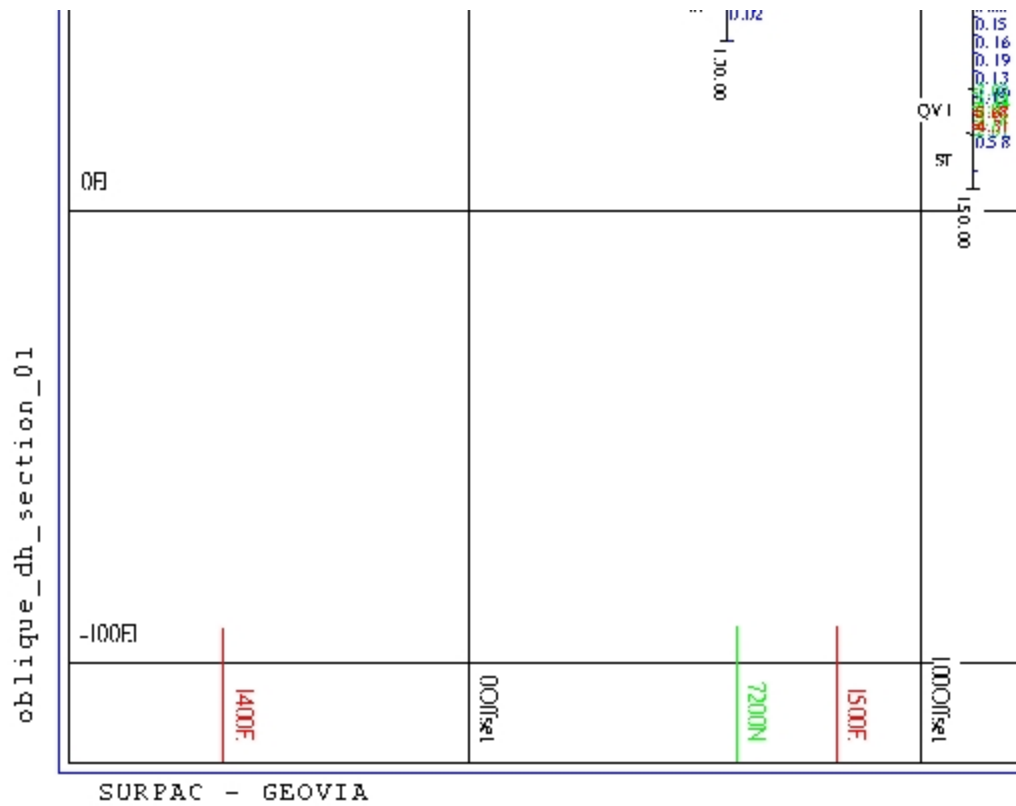

The real world Nothings and Eastings are displayed.

30. Close the **Plotting** window.

Note: To see all of the steps performed in this task, run **_05c_extract_oblique_section.tcl**. You need to click **Apply** on any forms presented.

Creating multiple section plots

Task: Create multiple section plots

1. Click **Reset graphics** .
2. Open **topo.str** and **ore.str**.
3. Connect to **surpac_training.ddb**.
4. Choose **Display > Drillholes**.
5. On the **Trace styles** tab, enter the information as shown, then click the **Geology patterns** tab.

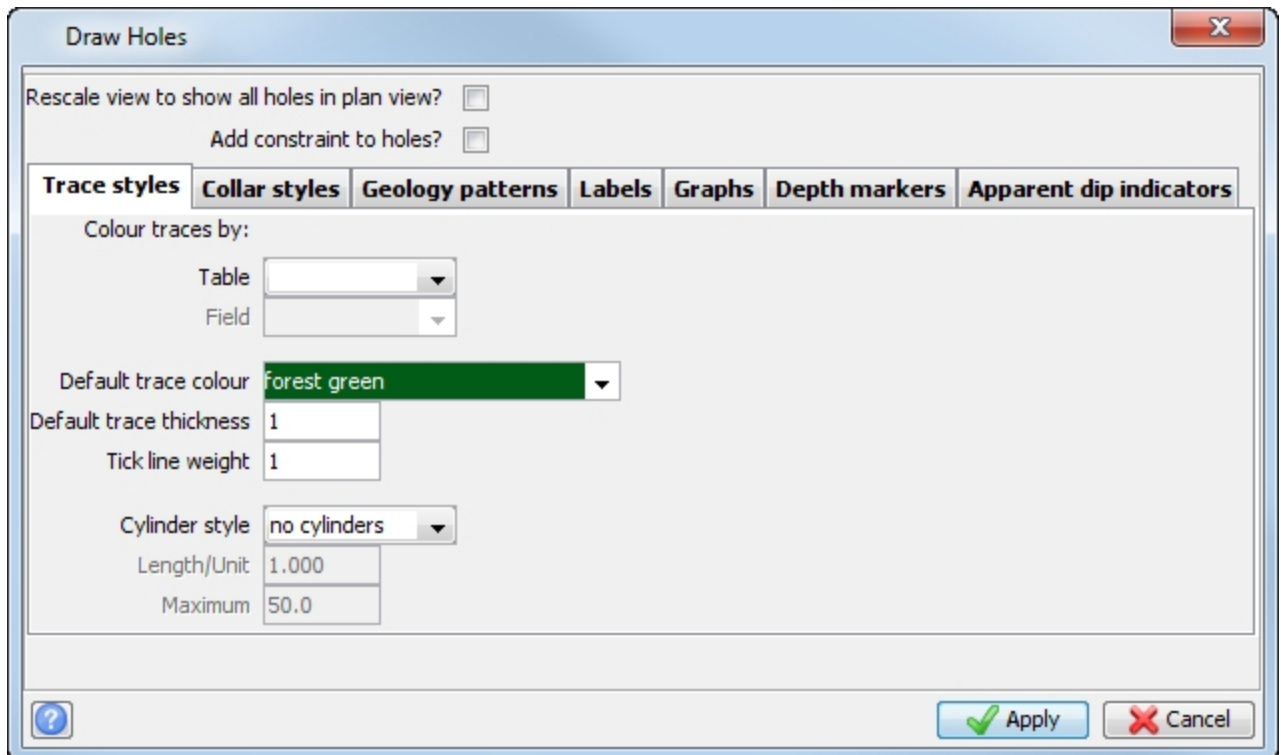

6. Enter the information as shown, and click the **Labels** tab.

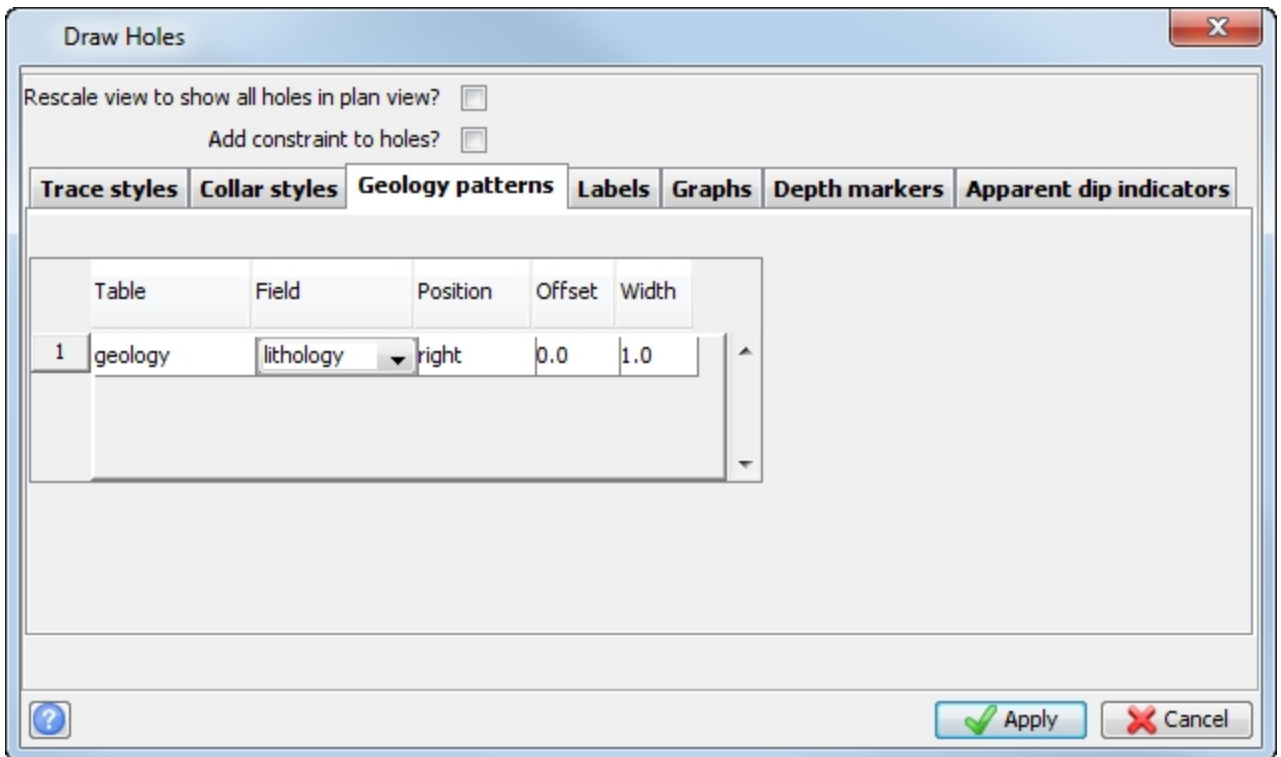

7. Enter the information as shown, and click **Apply**.

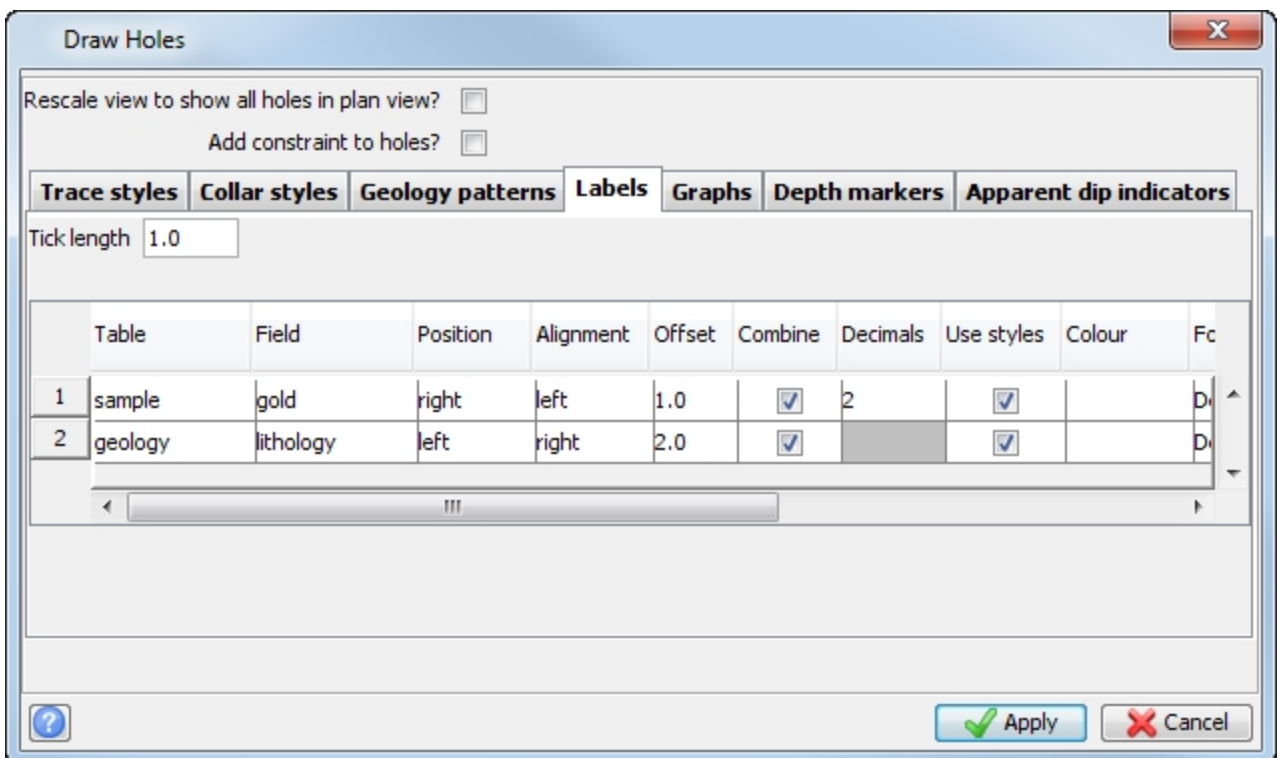

8. Click **Section view**.

9. In the **Planes** panel, double-click **7320N** in the **crossSections** group.

10. Click **Autoplot** .

11. Enter the information as shown.

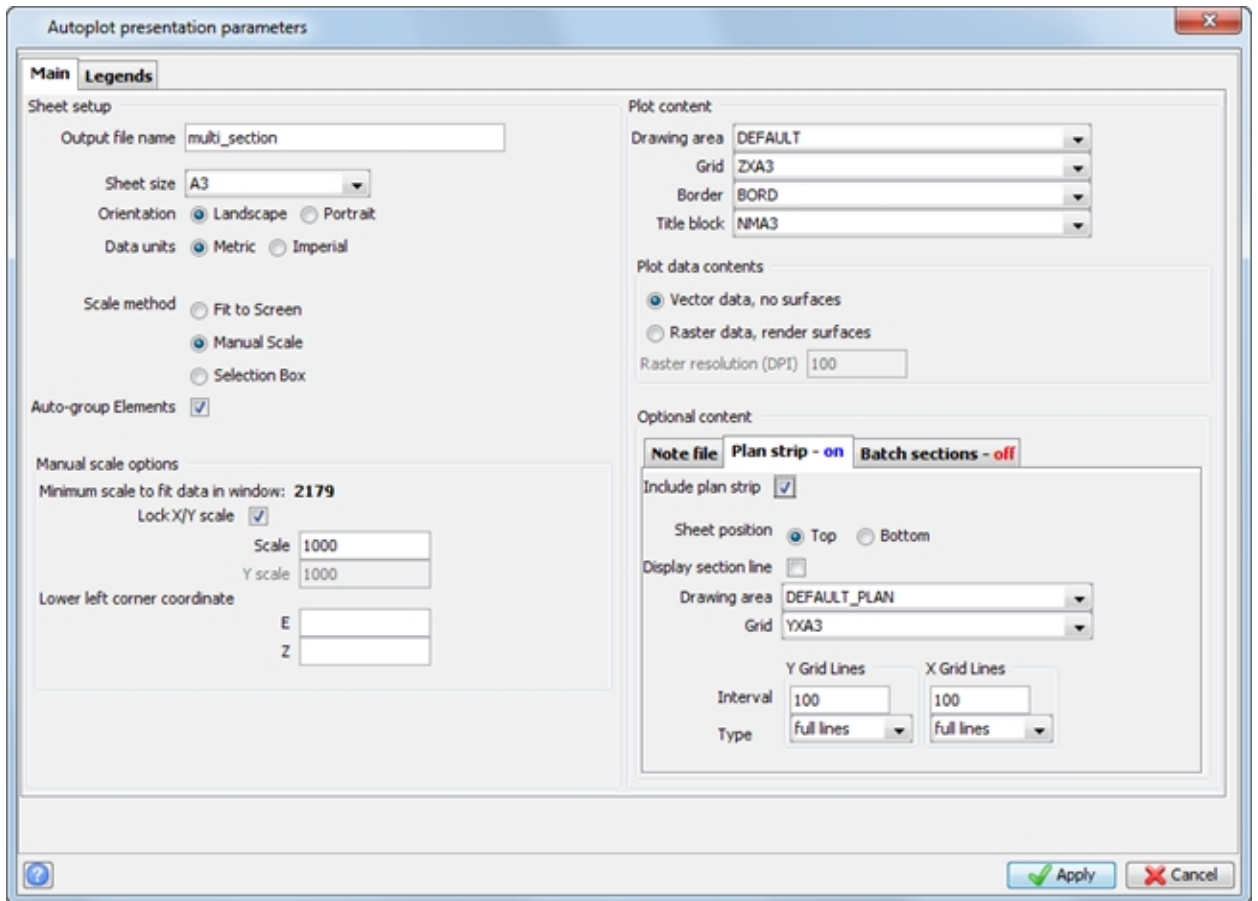

Note: The plots are named according to what is entered for the output file name and the name of the plane. In this case the first plot is named **multi_section_7320n.dwf**, with subsequent plots named **multi_section_7360n.dwf**, and **multi_section_7400n.dwf**.

12. Click the **Batch sections** tab.
13. Enter the information as shown, and click **Apply**.

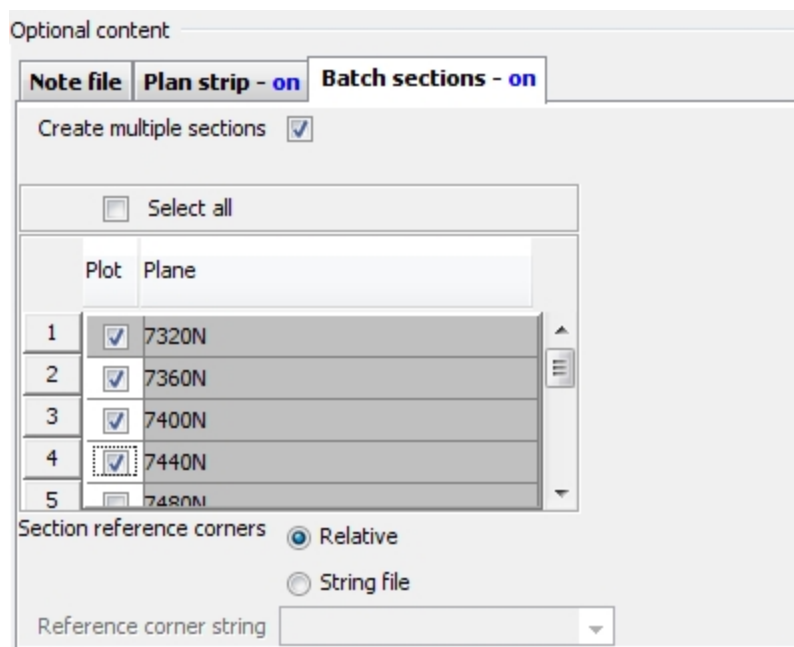

- Enter the information as shown, and click **Apply**.

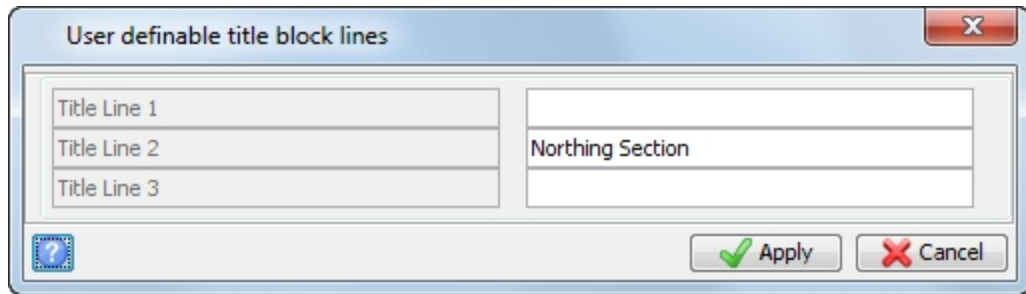

- Press F1.
- Click and drag in **Graphics** to move the box as shown.

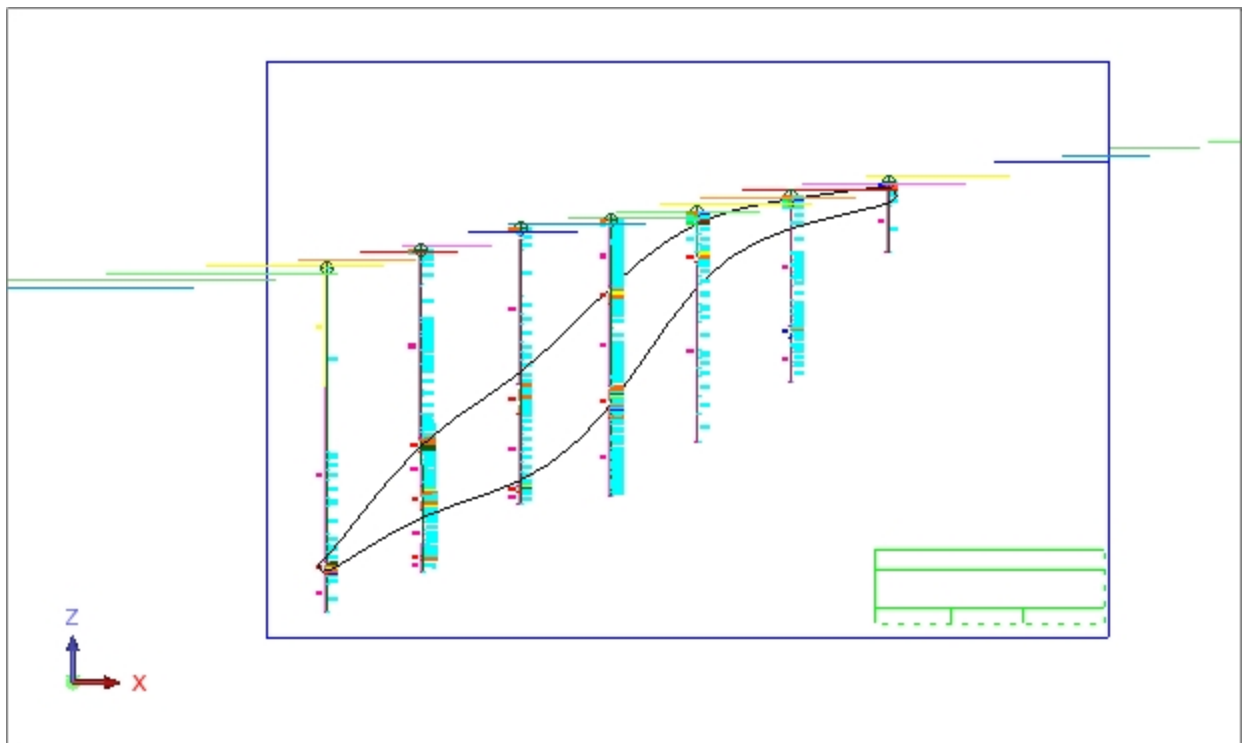

- Press F2.
- Enter the information as shown, and click **Apply**.

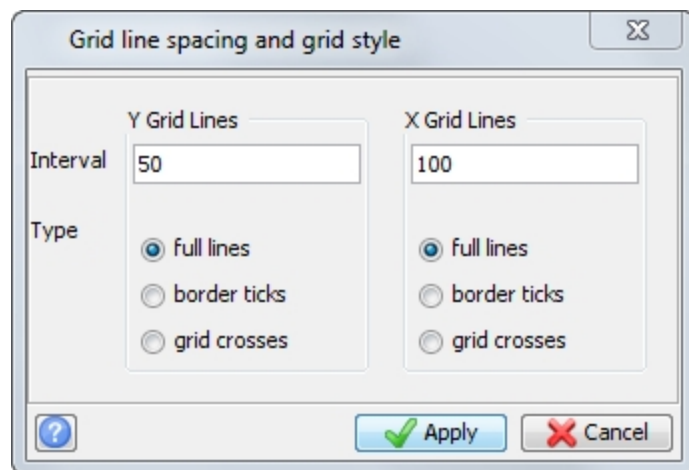

The following files are created:

Northing	Filename
7320	multi_section_7320n.dwf
7360	multi_section_7360n.dwf
7400	multi_section_7400n.dwf
7440	multi_section_7440n.dwf

19. Open **multi_section_7320n.dwf** in **Graphics** to display the plot in the **Plot Preview** window.

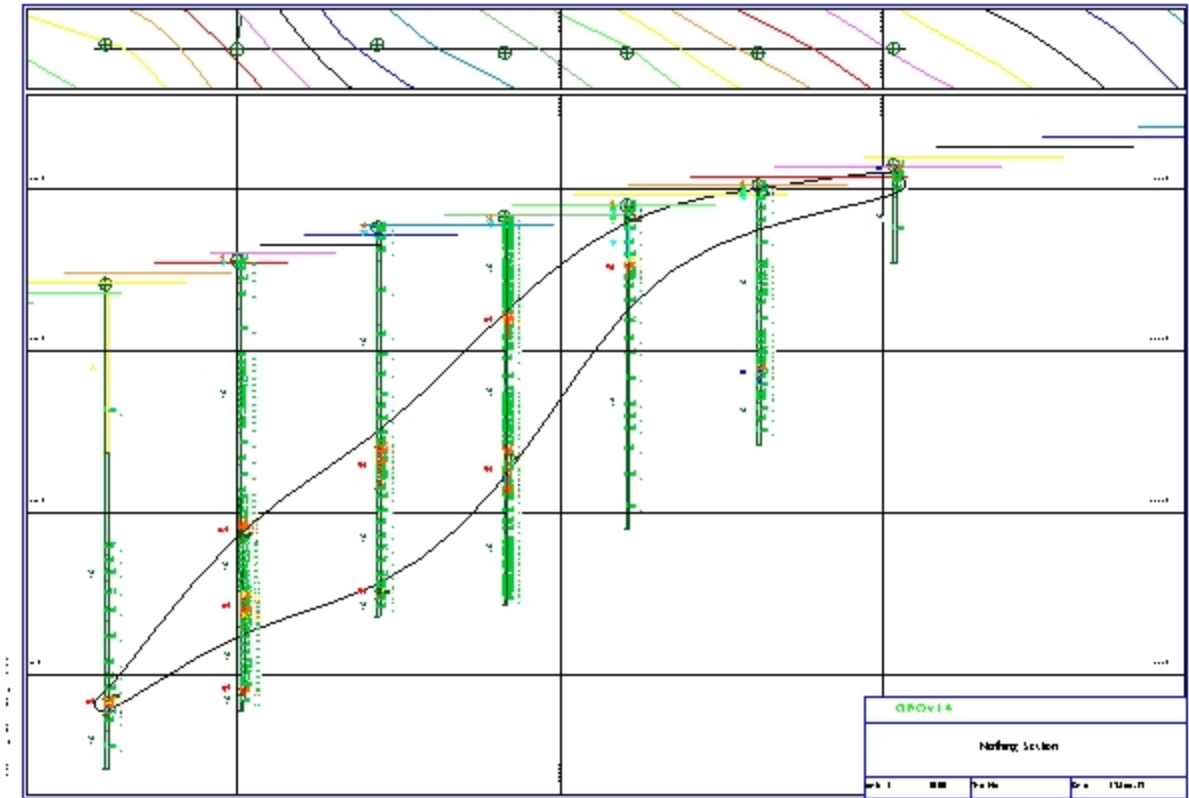

20. Double-click **multi_section_7360n.dwf** to display the plot.

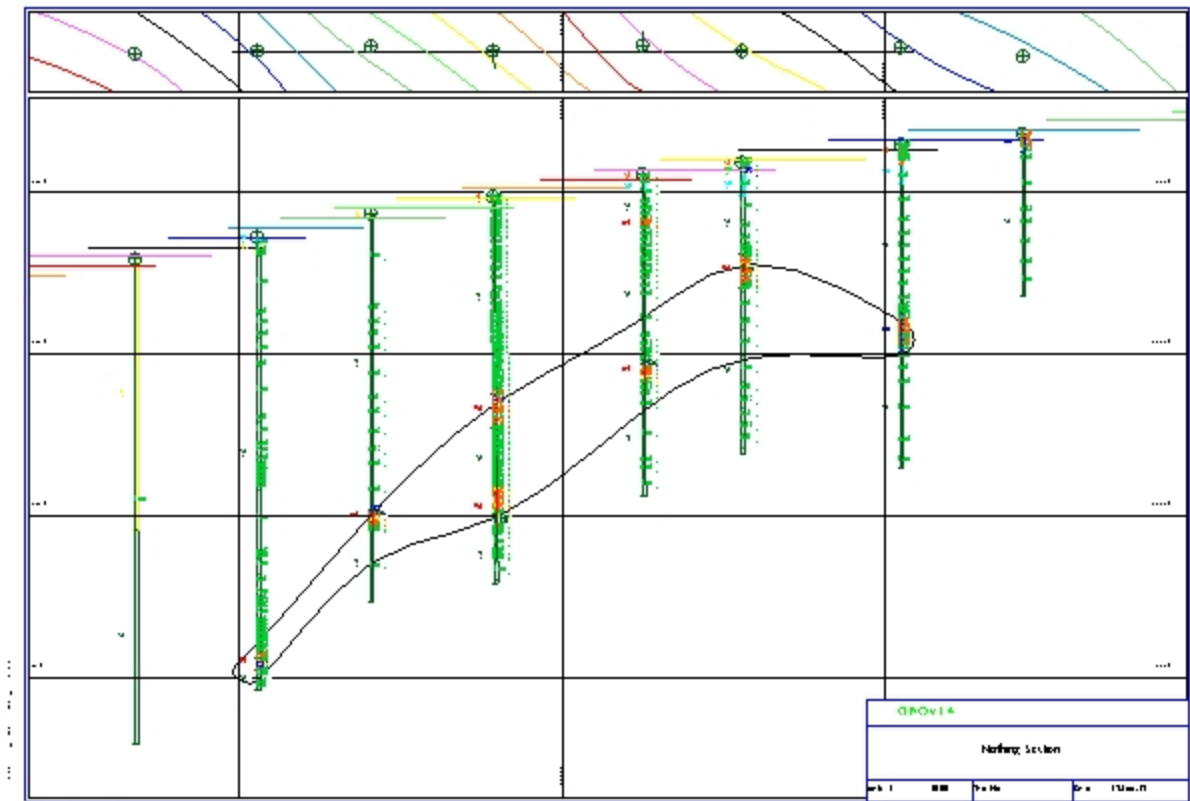

21. Double-click **multi_section_7400n.dwf** to display the plot.

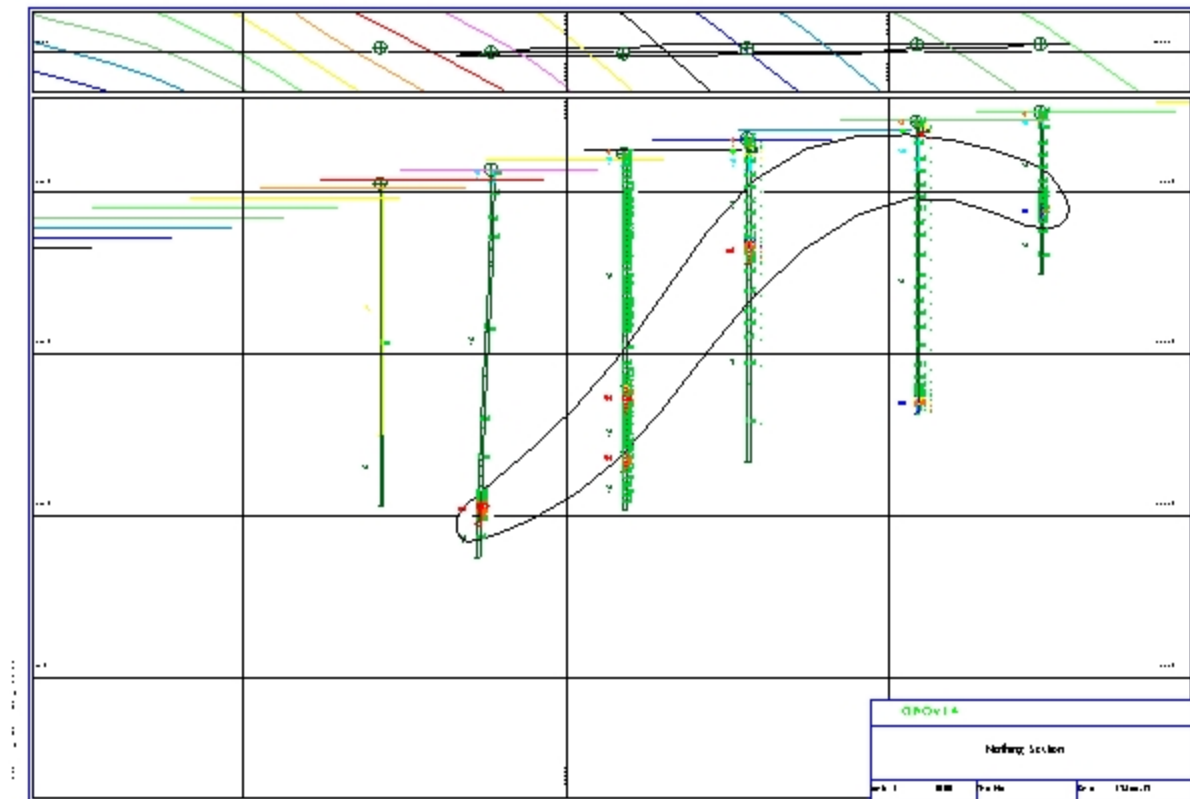

22. Double-click **multi_section_7440n.dwf** to display the plot.

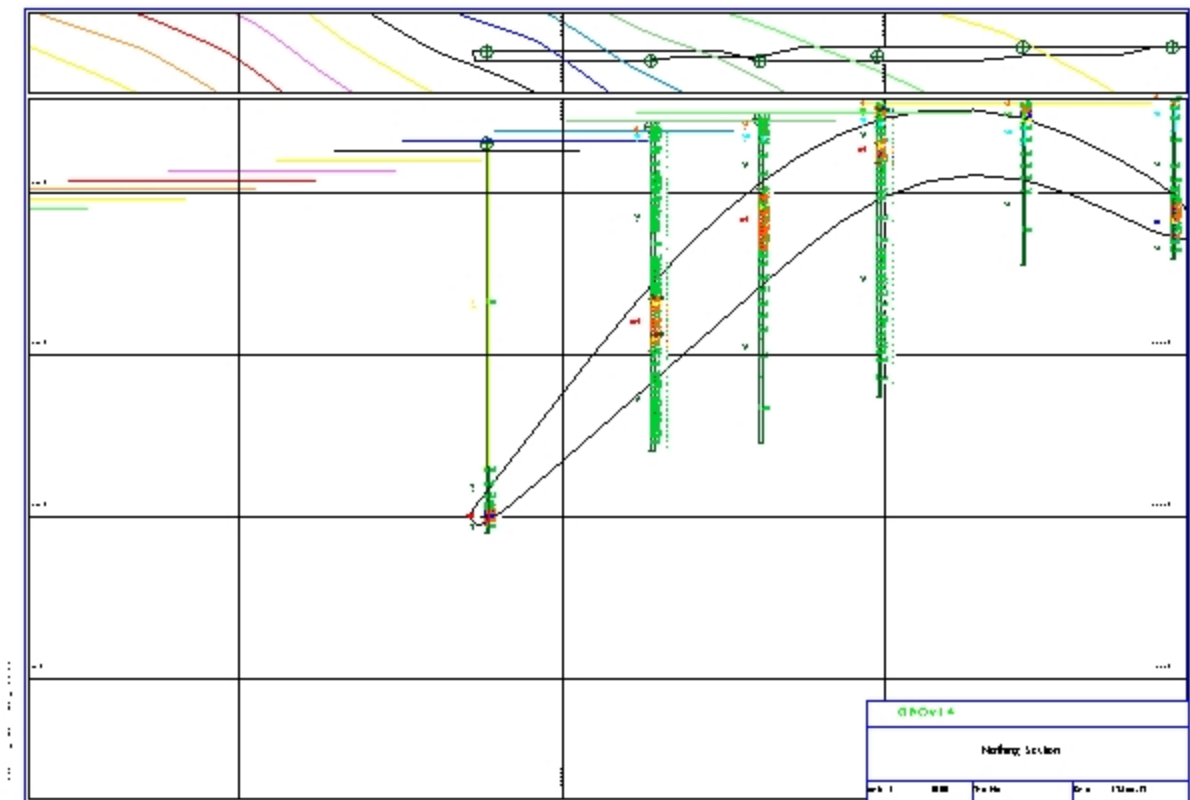

23. Choose **File > Close** to close the **Plot Preview** window.

Note: To see all of the steps in this task, run **05d_autoplot_multiple_sections.tcl**. You need to click **Apply** on any forms presented.

Creating a title block for multiple section plots

Task: Create a title block for multiple section plots

1. Choose **Plotting > Plotting Sheet setup** window.
2. Choose **Title Blocks > Copy**.

3. Enter the information as shown, and click **Apply**.

4. Click and drag the right and left mouse buttons and/or use the mouse wheel to zoom the title block, as shown.

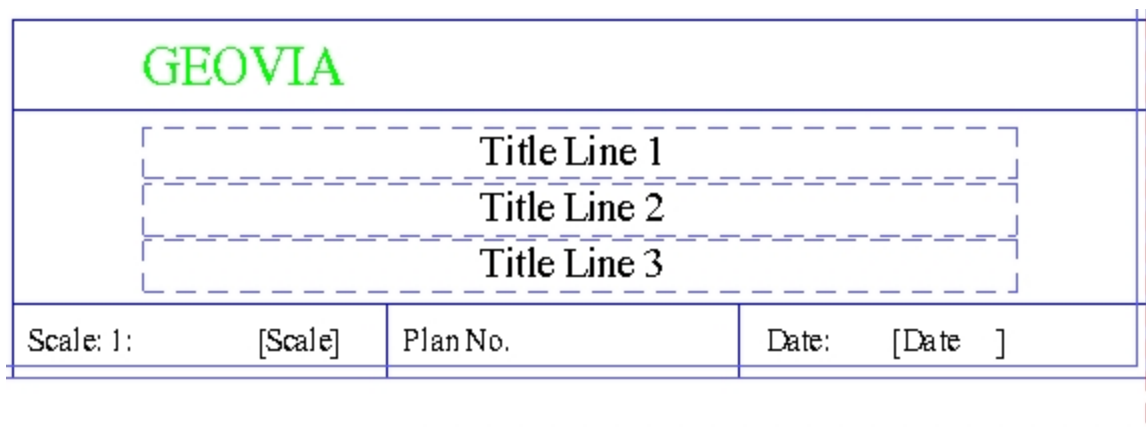

5. Choose **Title Blocks > Edit > Delete item**.
6. Click the text **Plan No.** to delete it.
7. Choose **Title Blocks > Create > Autoplot section details**.

8. Click near the previous location of **Plan No.**.
9. Enter the information as shown, and click **Apply**.
✘ **Note:** Insert a `<space>` after the last character of the Prefix, and before the first character of the Suffix. For example, the Northing Prefix is "Section`<space>`:`<space>`".

Section orientation	Prefix	Suffix
Northing	Section :	North
Easting	Section :	East
Elevation	Elevation :	mRL
Oblique		

Number of decimal places: 0

Title block options:

X position (lower left): 3.60
 Y position (lower left): 0.20
 Pen: 1
 Priority: 124

Font options:

Name: Default
 Bold:
 Italic:
 Underline:
 Text height: 0.20

The field name **[Autoplot section]** is displayed in the title block.

GEOVIA

Title Line 1
 Title Line 2
 Title Line 3

Scale: 1: [Scale]	[Autoplot section]	Date: [Date]
-------------------	--------------------	---------------

10. Choose **Title Blocks > Save**.
11. Choose **File > Close** to close the **Plot Preview** window.
 The **MULT** title block is now ready for you to use as the title block when you are plotting sections.
12. Click **Reset graphics** .

✘ **Note:** To see all of the steps in this task, run `05e_create_title_blocks_multiple_plots.tcl`. You need to click **Apply** on any forms presented.

Creating multiple section plots with title blocks

Task: Create multiple section plots with a title block

1. Run macro **04b_advanced_cross_sectional_viewing.tcl**.

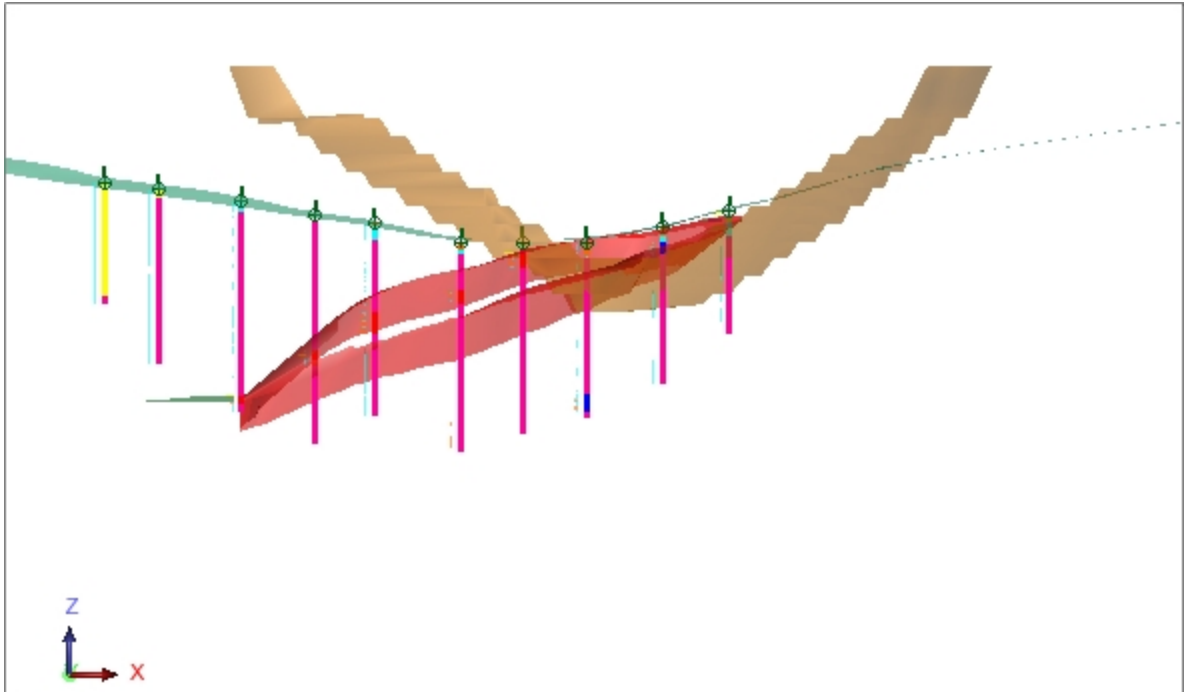

2. In the **Planes** panel, double-click **7320N** in the **crossSections** group.
3. Drag the **transparency slider** to set the transparency of triangles to 50%.

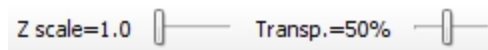

4. Click **Autoplot**  .

5. Enter the information as shown.

Note: When you select the Drawing area **VA1B** in Plot content, the only available option in the Optional content Drawing area is **VA1T**. Surpac displays only the drawing areas that are appropriate for the selected sheet size.

6. Click the **Batch section** tab.

7. Enter the information as shown.

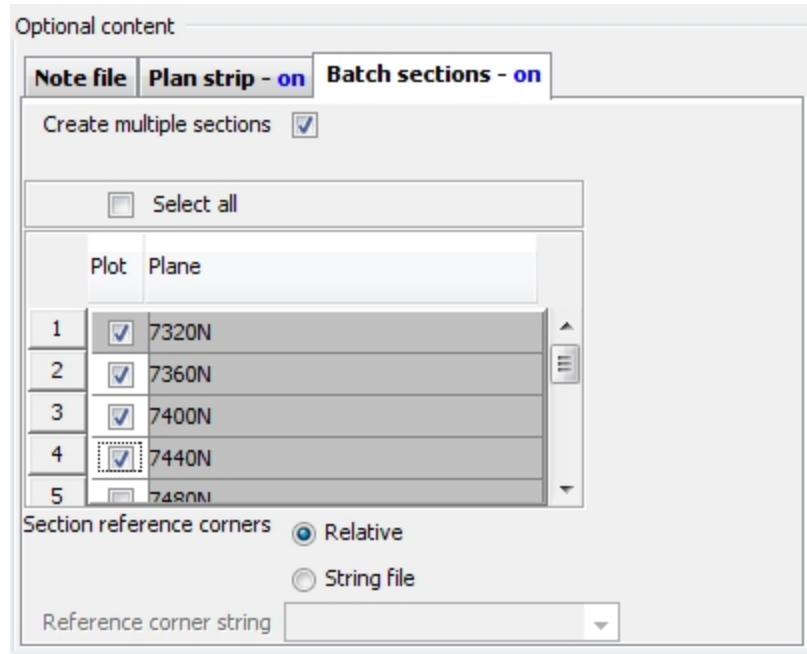

8. Click the **Legends** tab.

9. Enter the information as shown, and click **Apply**.

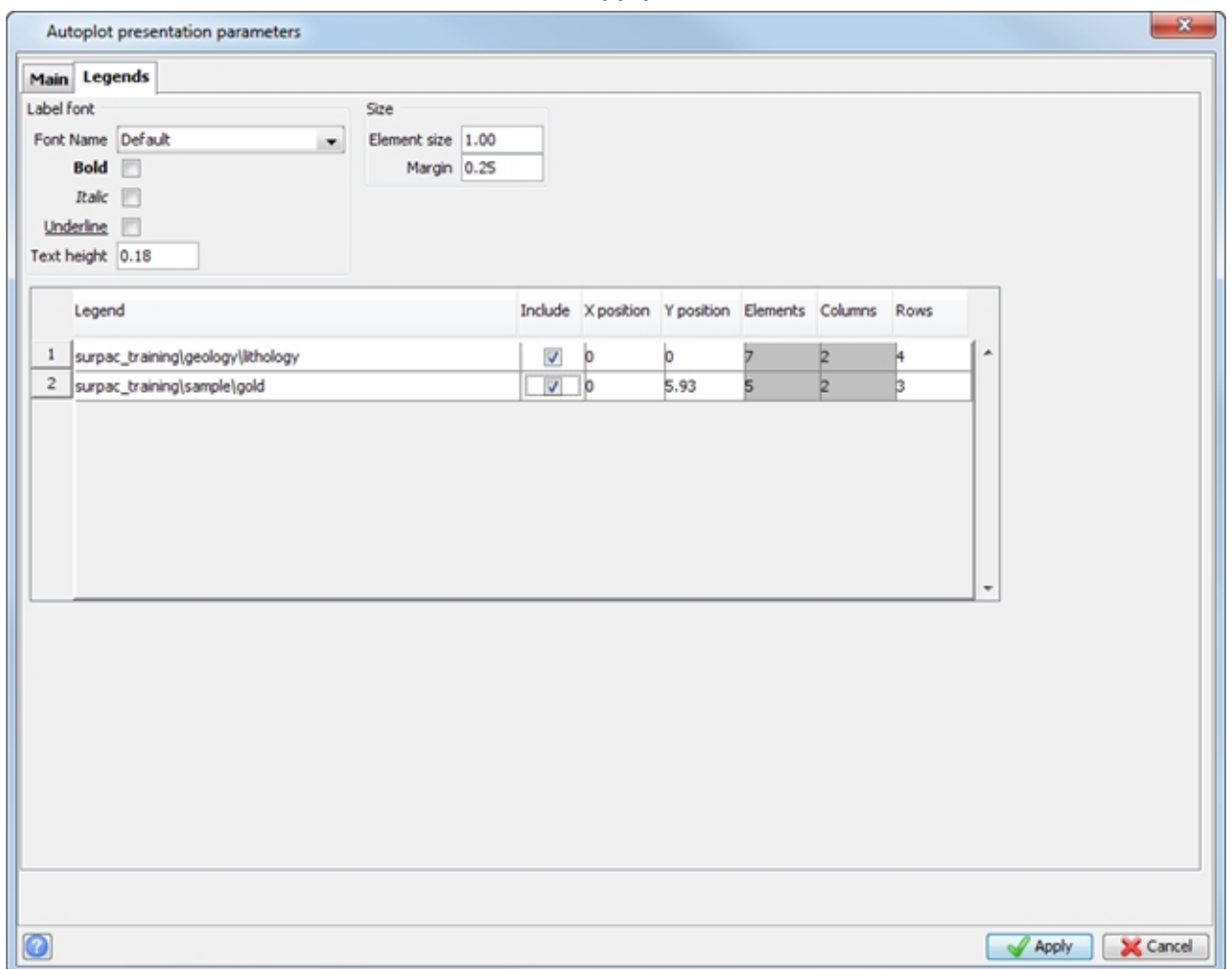

10. Enter the information as shown, and click **Apply**.

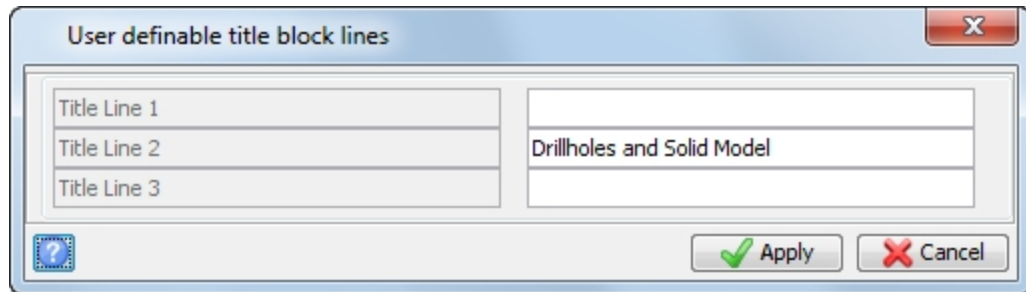

11. Press F1.
12. Click and drag in **Graphics** to move the box as shown.

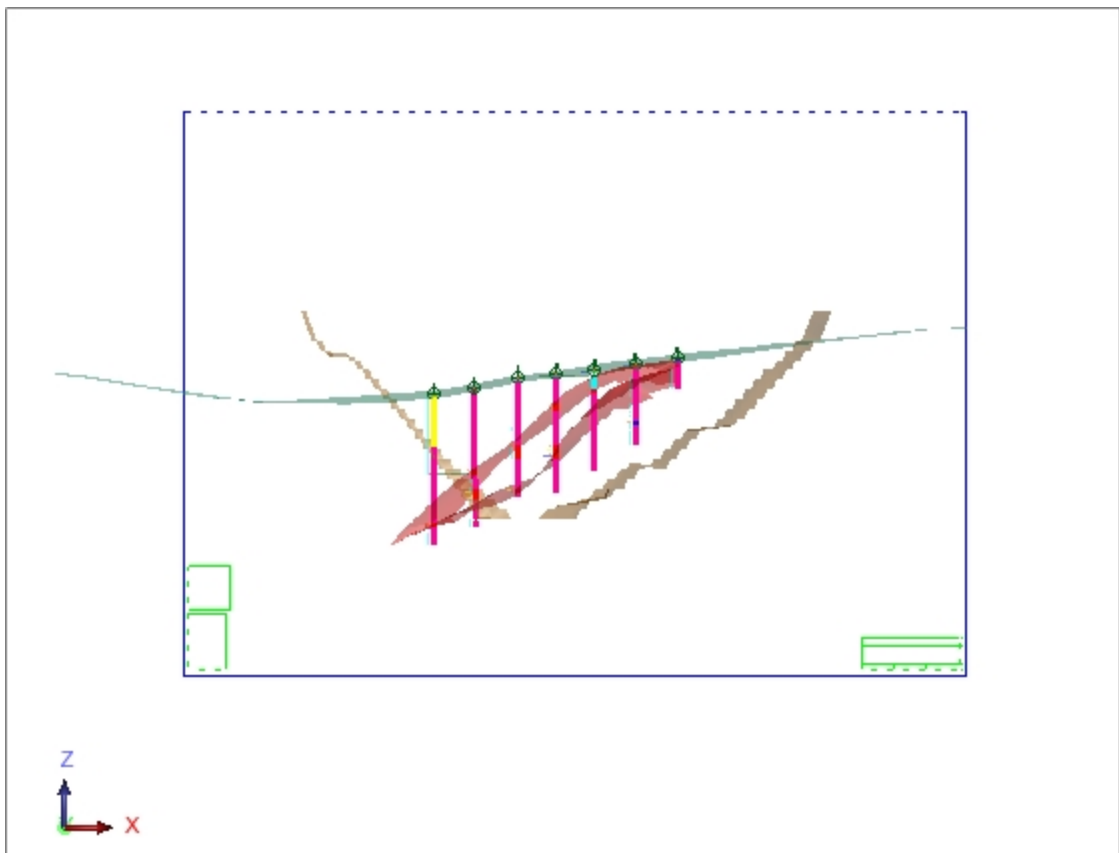

13. Press F2.

14. Enter the information as shown, and click **Apply**.

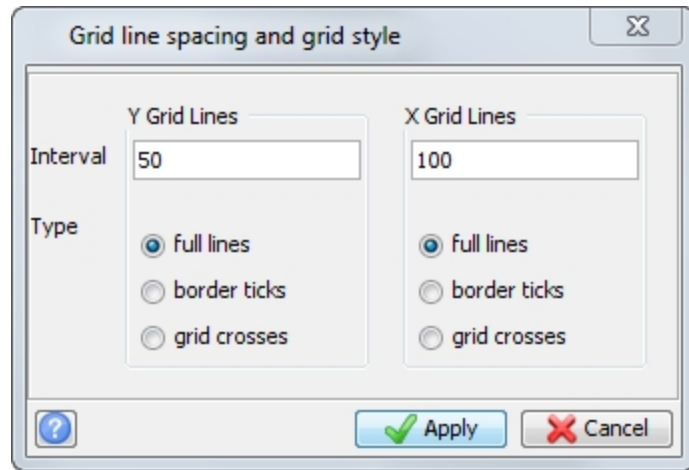

The following files are created:

Northing	Filename
7320	multi_solid_section_7320n.dwf
7360	multi_solid_section_7360n.dwf
7400	multi_solid_section_7400n.dwf
7440	multi_solid_section_7440n.dwf

15. Open **multi_solid_section_7320n.dwf** in **Graphics** to display the plot in the **Plot Preview** window.

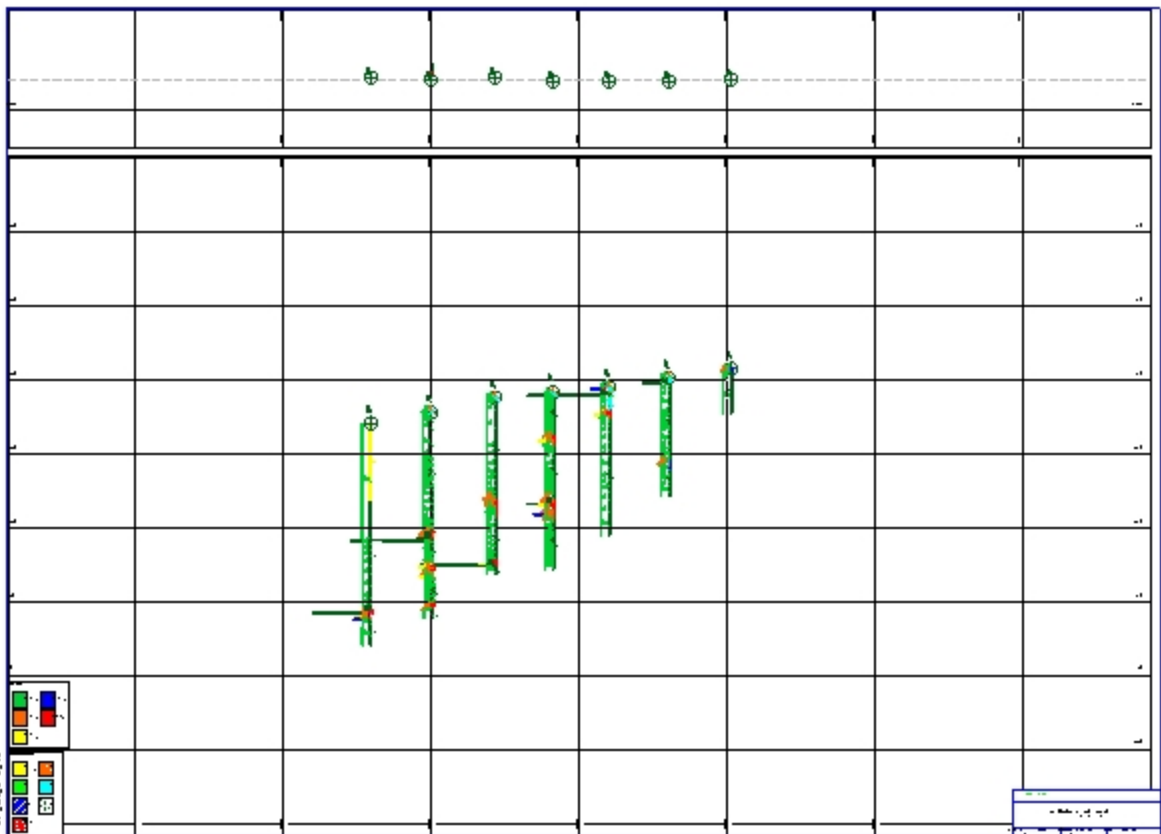

16. Zoom in on the title block.

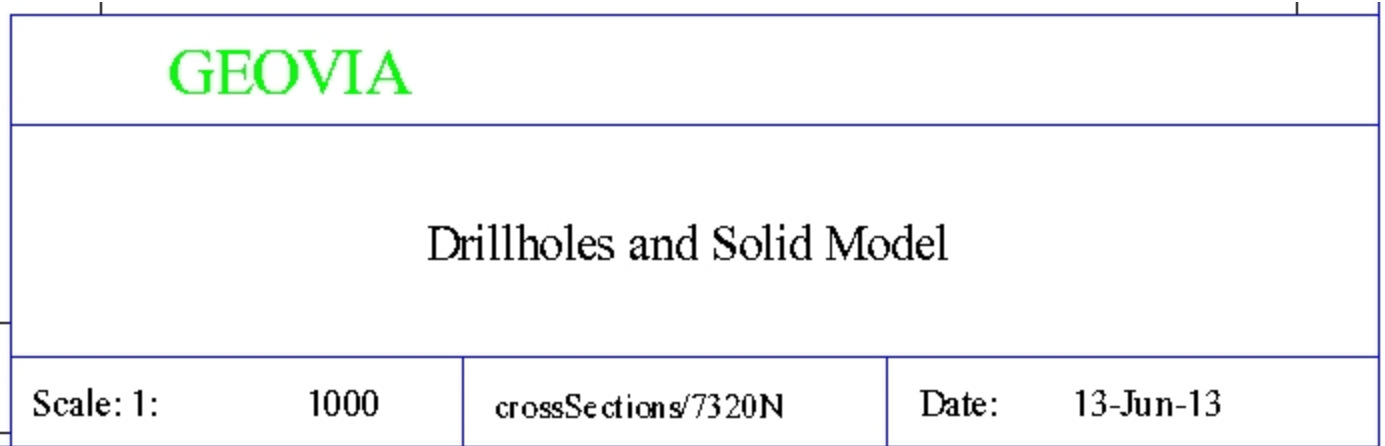

The Section number has been automatically appended to the title block.

17. Zoom in on the legend.

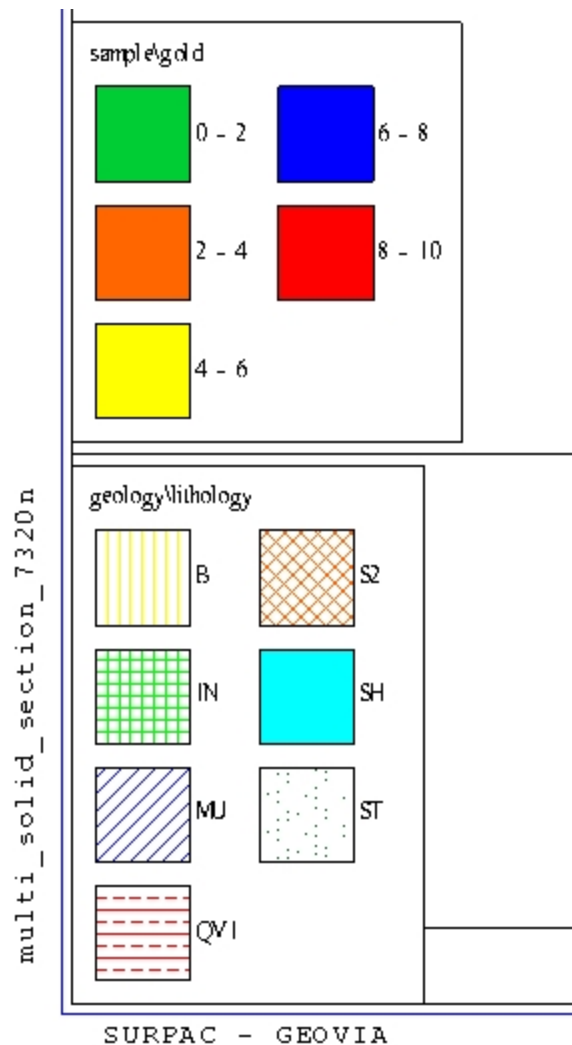

18. Open each of the files that were created:

multi_solid_section_7360n.dwf

multi_solid_section_7400n.dwf

multi_solid_section_7440n.dwf

19. Choose **File > Close** to close the **Plotting** window.

 **Note:** To see all of the steps in this task, run **05f_autoplot_multiple_solid_sections.tcl**. You need to click **Apply** on any forms presented.

Creating and plotting a sectional fence diagram

Task: Create a plot using a sectional fence diagram

1. Click **Reset graphics** .
2. Connect to **Surpac.ddb**.
3. Choose **Display > Drillholes**.
4. Enter the information as shown, and click the **Collar styles** tab.

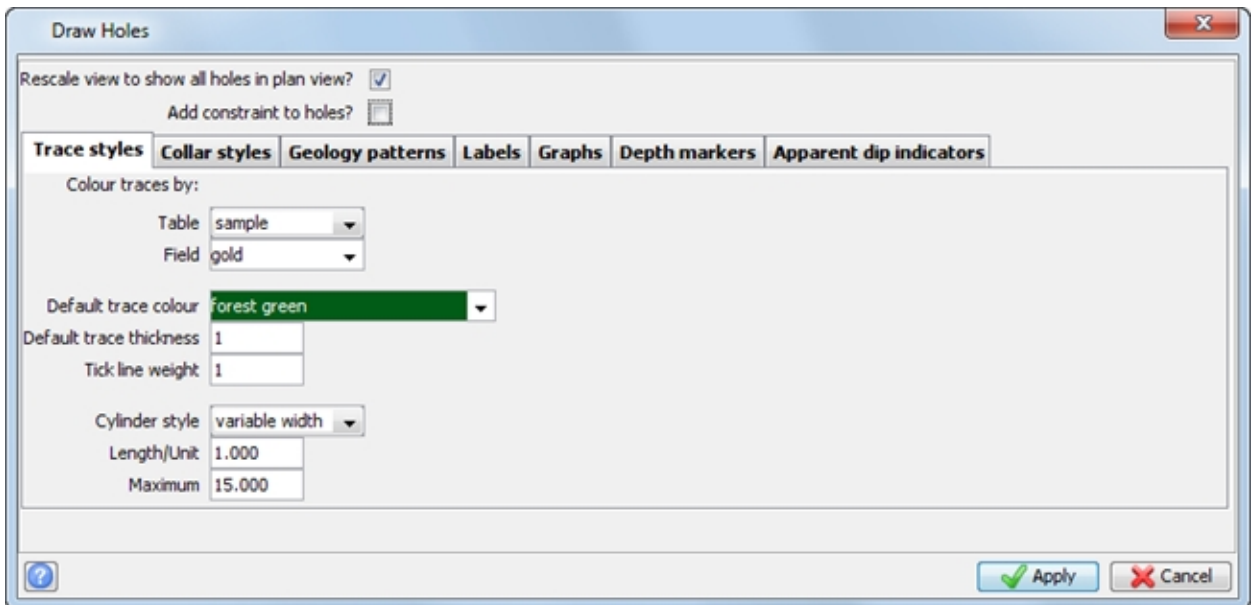

Draw Holes

Rescale view to show all holes in plan view?

Add constraint to holes?

Trace styles **Collar styles** **Geology patterns** **Labels** **Graphs** **Depth markers** **Apparent dip indicators**

Colour traces by:

Table: sample

Field: gold

Default trace colour: forest green

Default trace thickness: 1

Tick line weight: 1

Cylinder style: variable width

Length/Unit: 1.000

Maximum: 15.000

5. Enter the information as shown, and click the **Labels** tab.

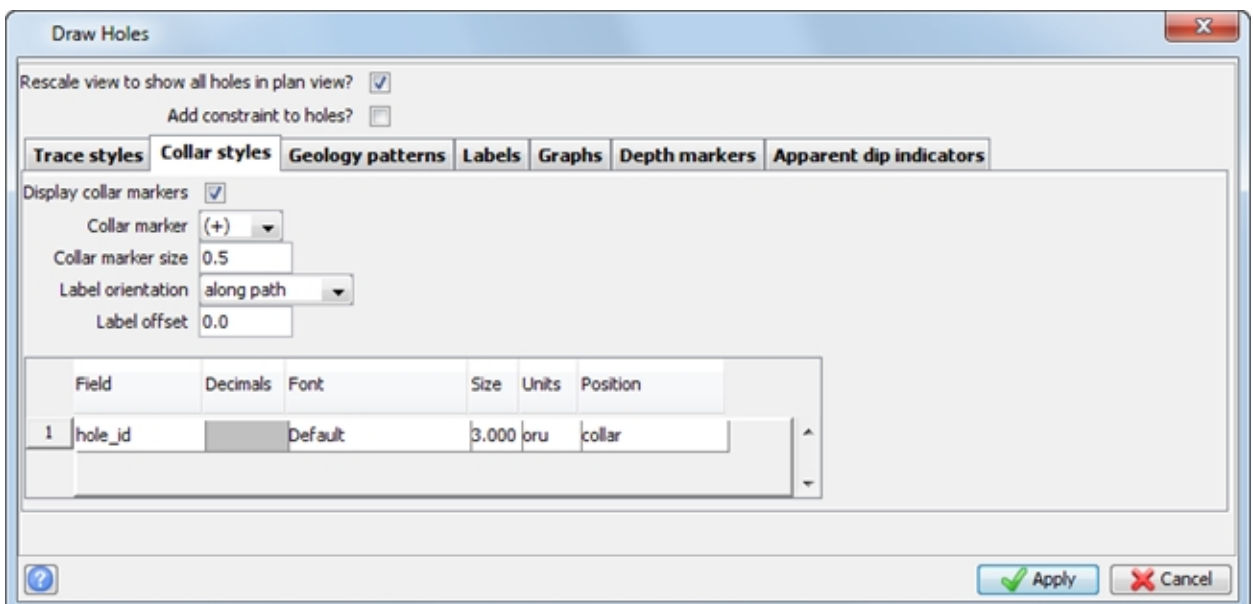

Draw Holes

Rescale view to show all holes in plan view?

Add constraint to holes?

Trace styles **Collar styles** **Geology patterns** **Labels** **Graphs** **Depth markers** **Apparent dip indicators**

Display collar markers

Collar marker: (+)

Collar marker size: 0.5

Label orientation: along path

Label offset: 0.0

	Field	Decimals	Font	Size	Units	Position
1	hole_id		Default	3.000	oru	collar

6. Enter the information as shown, and click **Apply**.

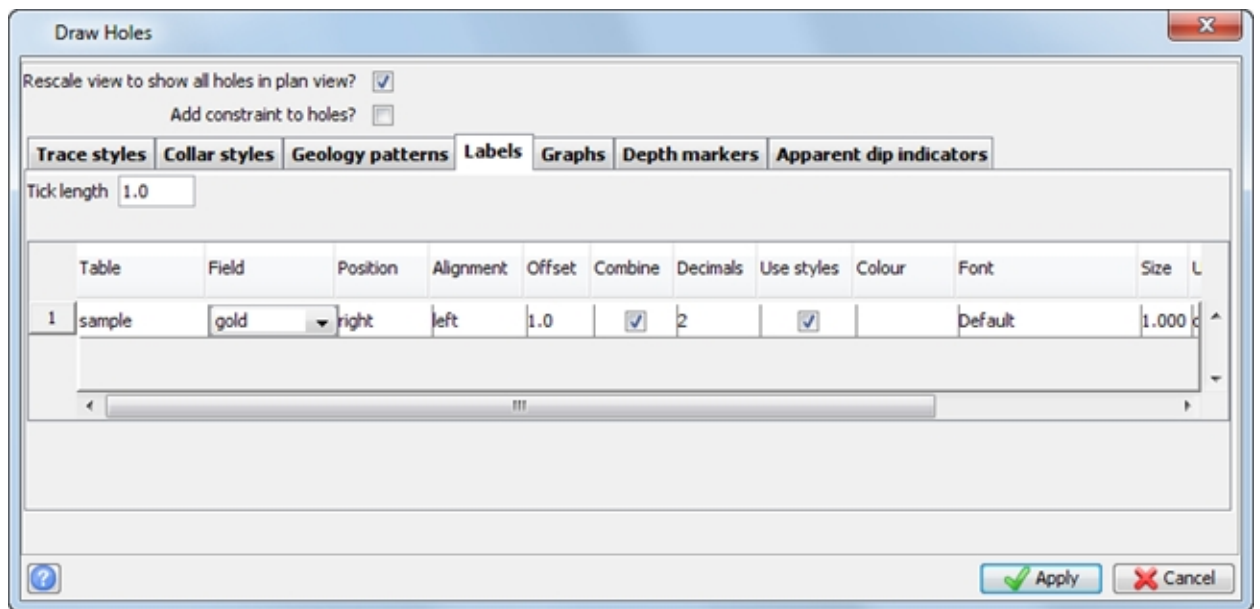

The drillholes are displayed with circular markers showing areas of high grade.

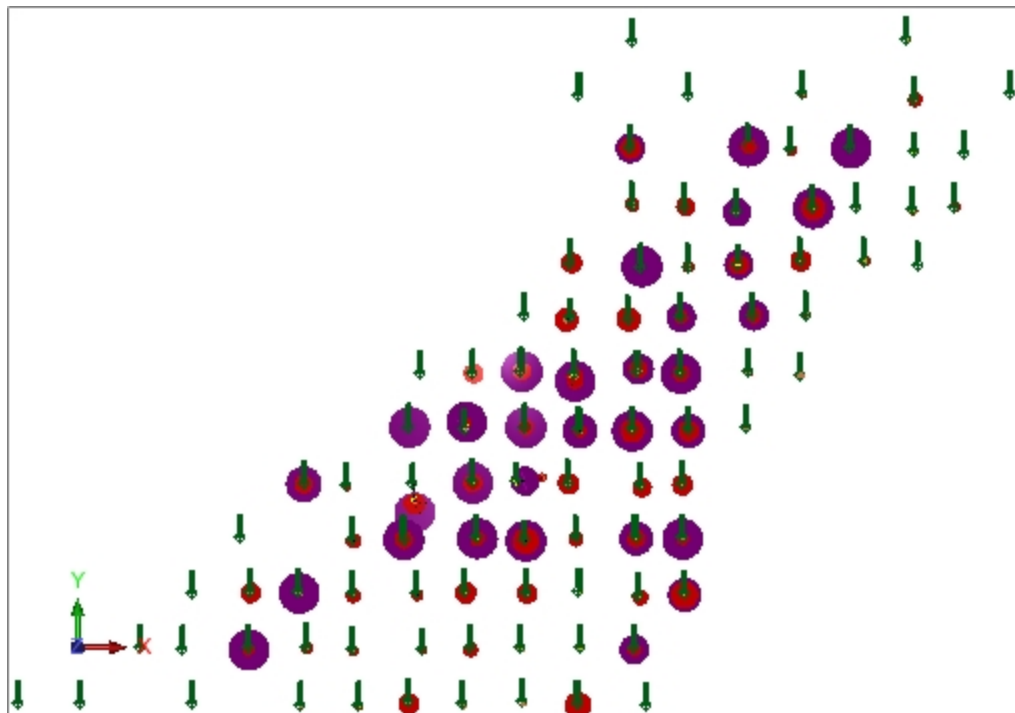

7. Choose **Extract > Section fence diagram for plotting**.
8. Map a path of drillholes through the high grade areas.
An example path is given in the following image.

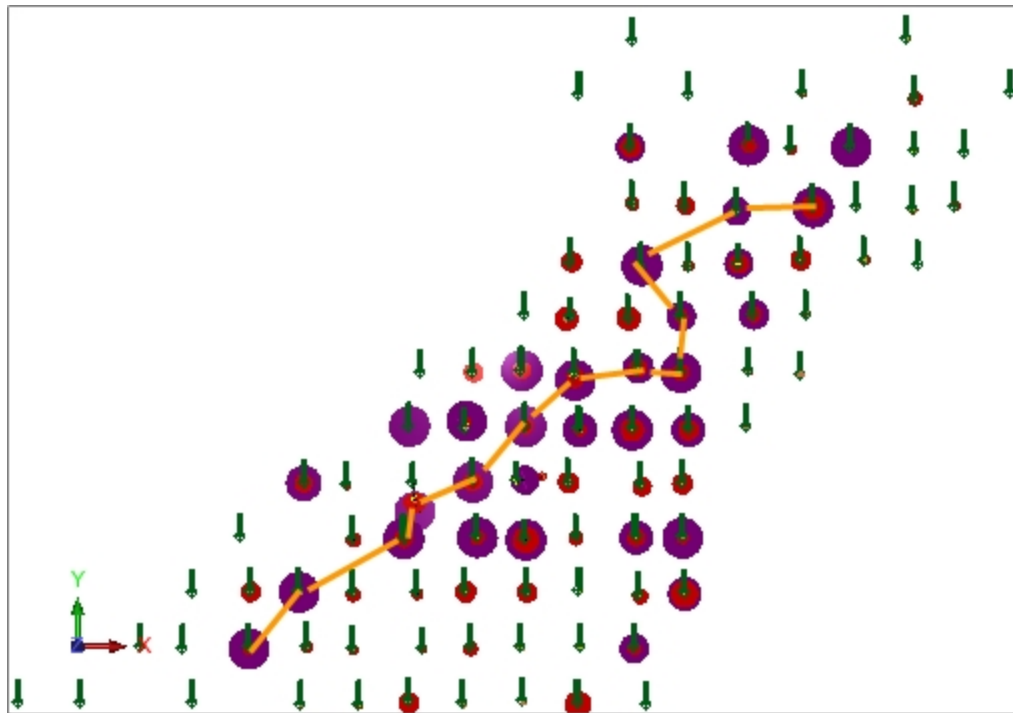

 **Note:** The colored path shown in the example above is to demonstrate a possible path through high grade areas. The path is not displayed in **Graphics** when you select the drillholes.

9. Press ESC.
The *Extract section fence diagram for plotting* form is displayed.
10. Enter the information as shown, and click **Apply**.

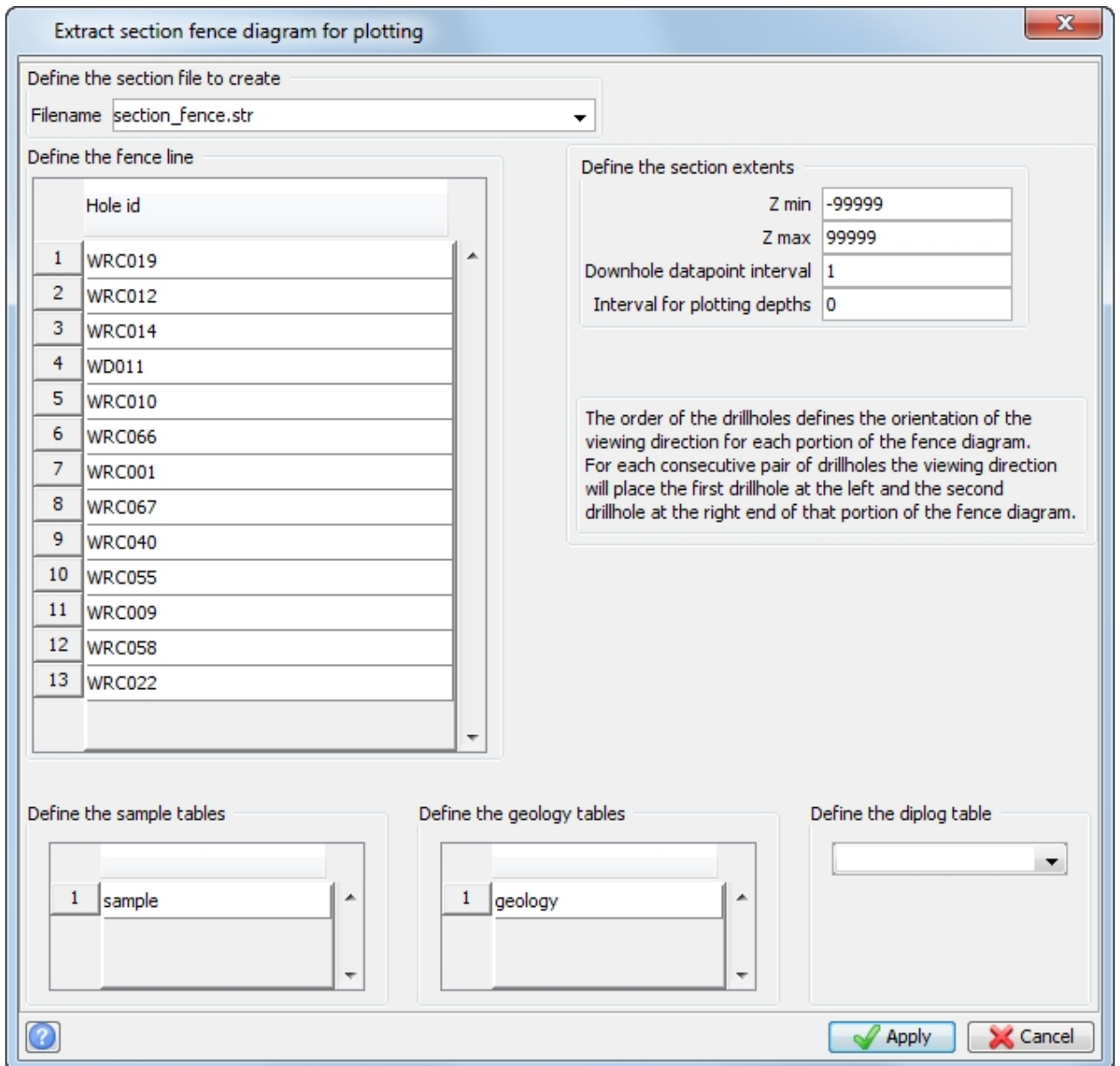

The *Define sample fields for plotting* form is displayed.

11. Enter the information as shown, and click **Apply**.

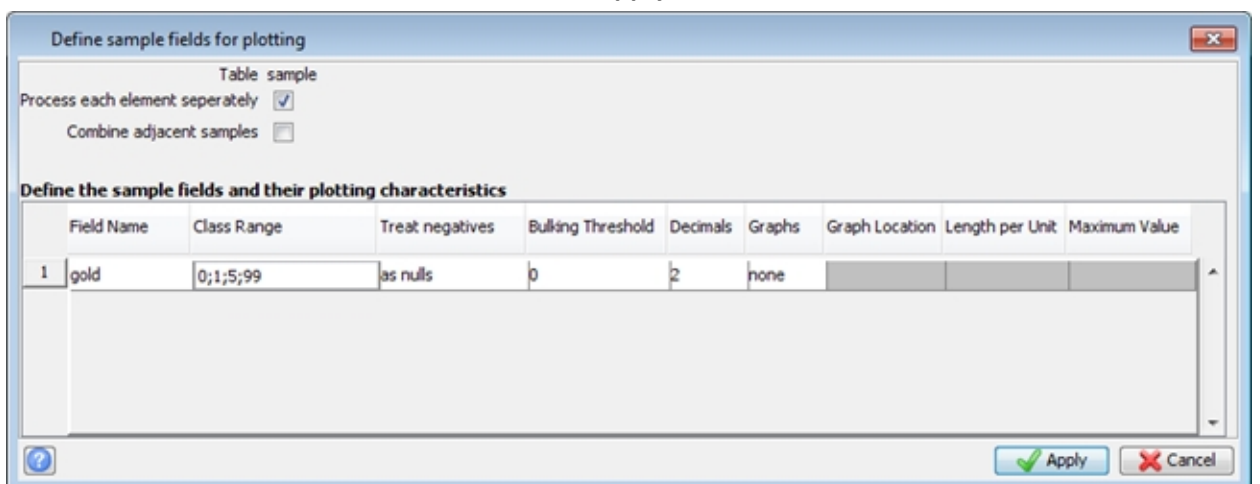

The *Define geology fields* form is displayed.

12. Enter the information as shown, and click **Apply**.

	Field Name	Geology Location	Box Size
1	rock	left	5

13. Click **Reset graphics** .
 14. Open **section_fence.str** in **Graphics**.
 15. Choose **Plotting > Map > Copy**.
 16. Enter the information as shown, and click **Apply**.

17. Choose **Plotting > Map > Edit**.
 18. Enter the information as shown, and click **Apply**.

The *Define a map* form is displayed.

19. Change the **Location** to **section_fence.str** and clear the **ID Range** for all entities, then click **Apply**.

Define a map

Map name SECTION_FENCE

	Entity	Location	ID range	String range	Segment range
1	DH TRACE	section_fence		1	
2	DH TRACE NO TOP	section_fence		2	
3	DH TRACE NO BOT	section_fence		3	
4	DH TRACE NO TOPBOT	section_fence		4	
5	DH LABEL	section_fence		5	
6	DH EOH DEPTH	section_fence		5	
7	DH ASSAY1 RHS/PN2	section_fence		11	
8	DH ASSAY1 RHS/PN3	section_fence		12	
9	DH ASSAY1 RHS/PN4	section_fence		13	

Apply Cancel

20. Choose **Plotting > Process > Map**.
21. Enter the information as shown, and click **Apply**.

Process existing map definitions

1 SECTION_FENCE

Apply Cancel

The *Plot presentation parameters* form is displayed.

22. Enter the information as shown, and click **Apply**.

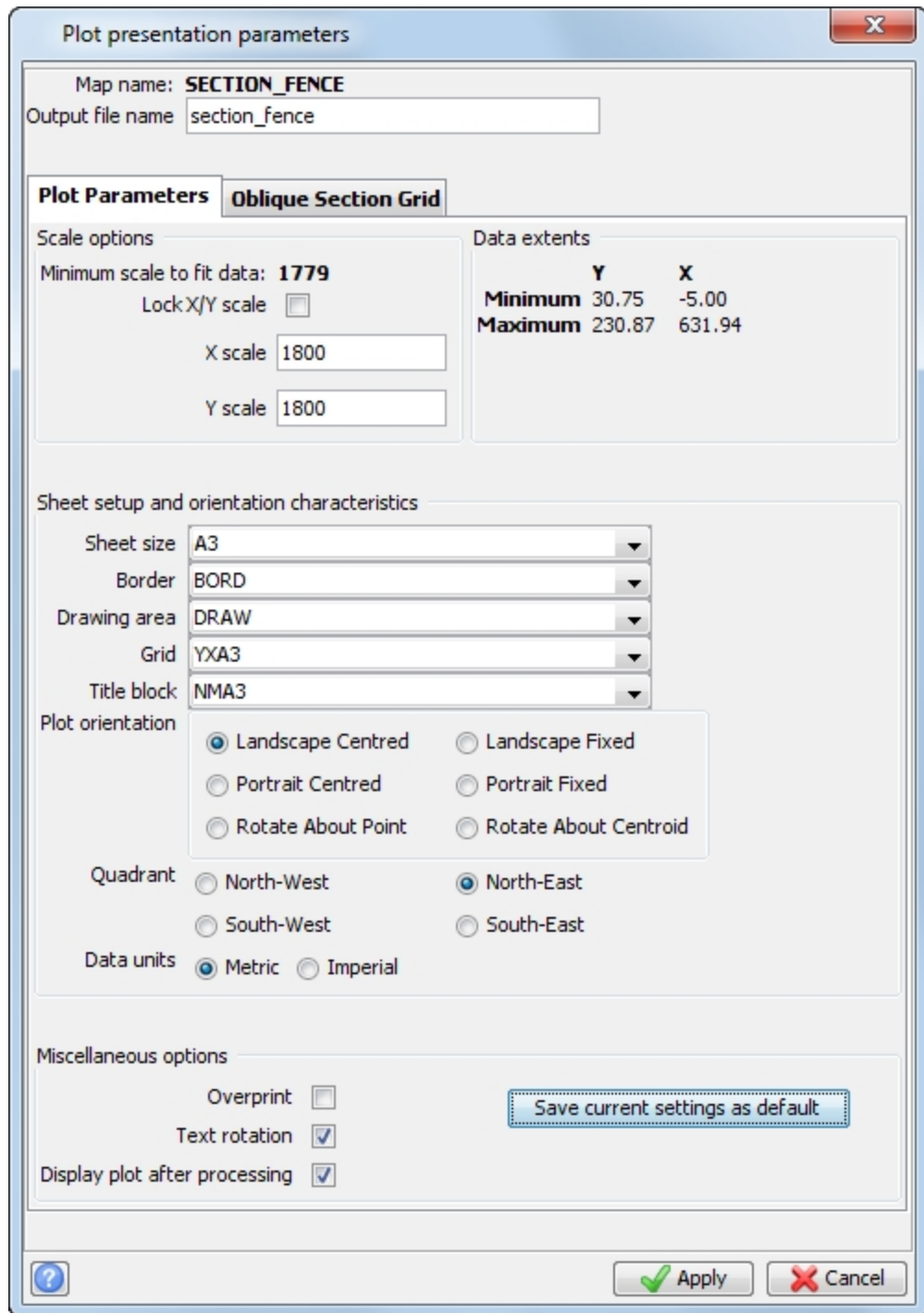

The *User definable title block lines* form is displayed.

23. Enter the information as shown, and click **Apply**.

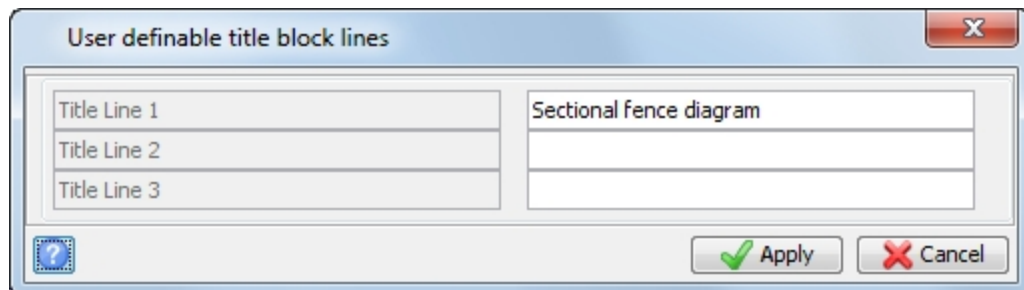

The *Grid line spacing and grid style* form is displayed.

24. Enter the information as shown, and click **Apply**.

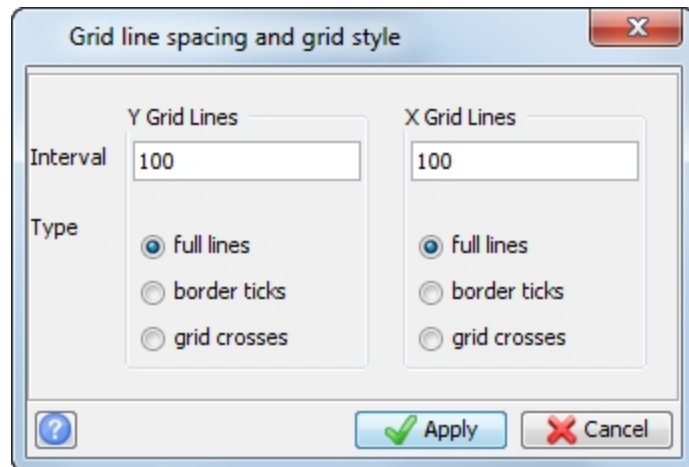

Grid line spacing and grid style

Y Grid Lines

Interval: 100

Type:

- full lines
- border ticks
- grid crosses

X Grid Lines

Interval: 100

Type:

- full lines
- border ticks
- grid crosses

Apply Cancel

The drillholes are plotted and displayed in the **Plotting** window.

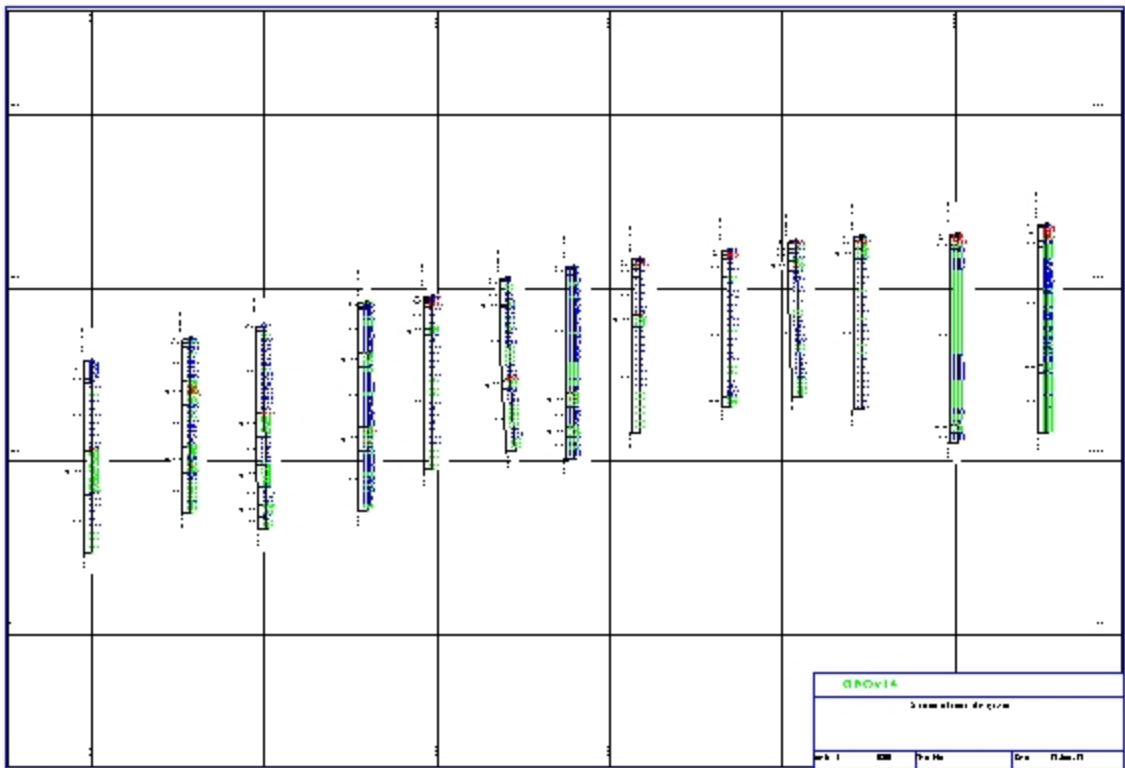

Compositing

Compositing by elevation

Task: Perform composite by elevation

You can use this function to create one or more string files which contain elevation composites of sample data. The composites can be weighted by length alone or by other fields in the table containing the sample data including specific gravity and recovery.

1. Connect to **surpac_training.ddb**.
2. Choose **Composite > Bench elevations**.
Drill Holes are processed as described below:

All samples, or fractions of samples, of the drill hole, which are within the nominated elevations for the composite, are reduced to a single point value. This value has the length-weighted average of all samples that intersected the elevation range of interest.

If the total vertical length of the samples, as a percentage of the vertical height of the elevation bounds of the composite, is less than a defined threshold percentage, the hole is ignored. This gives you some control over whether drill holes which only partially intersect the elevation composite are included or excluded from the final result.

3. Enter the information as shown, and click **Apply**.

Composite by elevation

Define the composite files to create

Location: benchcomp

Elevation range: 50,250,10

Define the Sample fields

Define the Interval table: sample

Field Name	
1	gold

Define the elevation extent and type

Extent: 5

Type: either side of the elevation l...

Define the parameters

Define the output class range: 0,2;3;5;10;999

Minimum acceptable % of interval: 50

Threshold dip for channels: 5

Dilute negative samples:

Optional weighting fields

Field Name		Default
1	gold	1

Buttons:

- Enter the information as shown, and click **Apply**.

Define query constraints			
Table Name collar			
	Field Name	Operand	Constraint Value
1	[Dropdown]	=	

A set of string files is produced called **benchcomp50.str**, **benchcomp60.str** in increments of 10 up to **benchcomp240.str**.

- Open **benchcomp100.str** in **Graphics**.
- Choose **Display > Hide everything**.
- Choose **Display > Point > Markers**.
- Enter the information as shown, and click **Apply**.

- Choose **Display > Point > Attributes**.
- Enter the information as shown, and click **Apply**.

The values of the composites at bench level 100 are displayed.

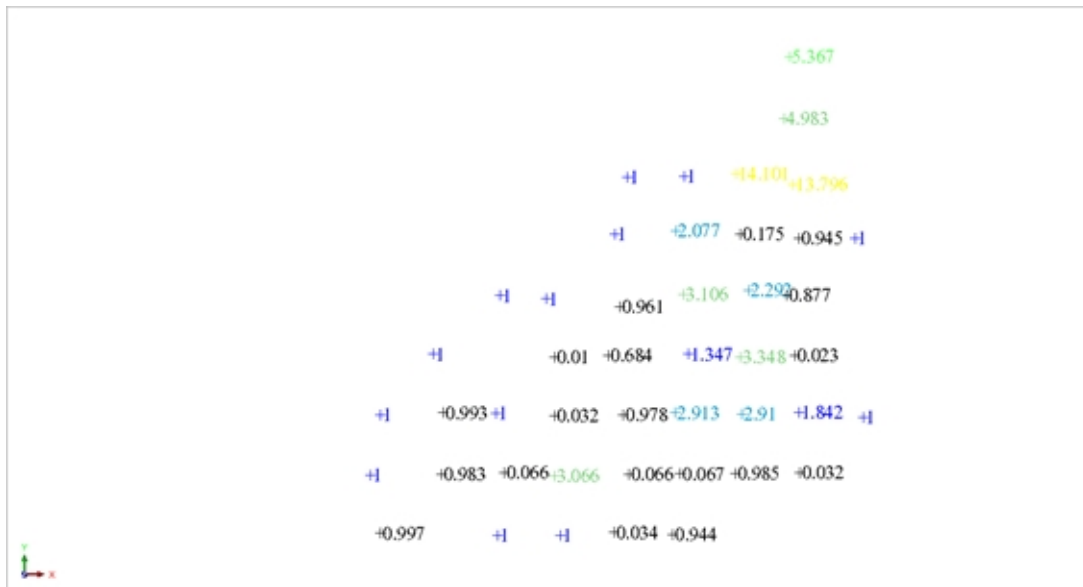

 **Note:** To see all of the steps in this task, run **06a_composite_by_elevation.tcl**. You need to **Apply** any forms presented.

Compositing downhole

Task: Perform composite downhole

1. Choose **Composite > Downhole**.
2. Enter the information as shown, and click **Apply**.

Composite downhole

Define the string file to create

Location comp

ID number 1

String 1

Composite length 1

Determine composite length by fixed length

Minimum % of sample to be included 75

Define the zone selection method

NO SELECTION

MULTIPLE ZONES

ZONE FROM TO

Dilute negative samples

Table name sample

Fields to be composited

	Field Name
1	gold

Optional weighting fields

	Field Name	Default	Include Limit
1		1	

Apply Cancel

3. Enter the information as shown, and click **Apply**.

Table Name	collar		
	Field Name	Operand	Constraint Value
1	[Dropdown]	=	

4. Click **Reset graphics** .
5. Open **comp1.str** in **Graphics**.
6. Choose **Display > Hide strings > In a layer**.
7. Enter the information as shown, and click **Apply**.

Layer name	comp1.str
String range	
Segment range	

8. Choose **Display > Point > Markers**.
9. Enter the information as shown, and click **Apply**.

Layer name	comp1.str
String range	
Seg range	
Seg pnt range	
Desc field number	d1
Text Alignment	<
Position of text in segment	<input checked="" type="radio"/> All points <input type="radio"/> First point <input type="radio"/> Centroid

The composites are displayed.

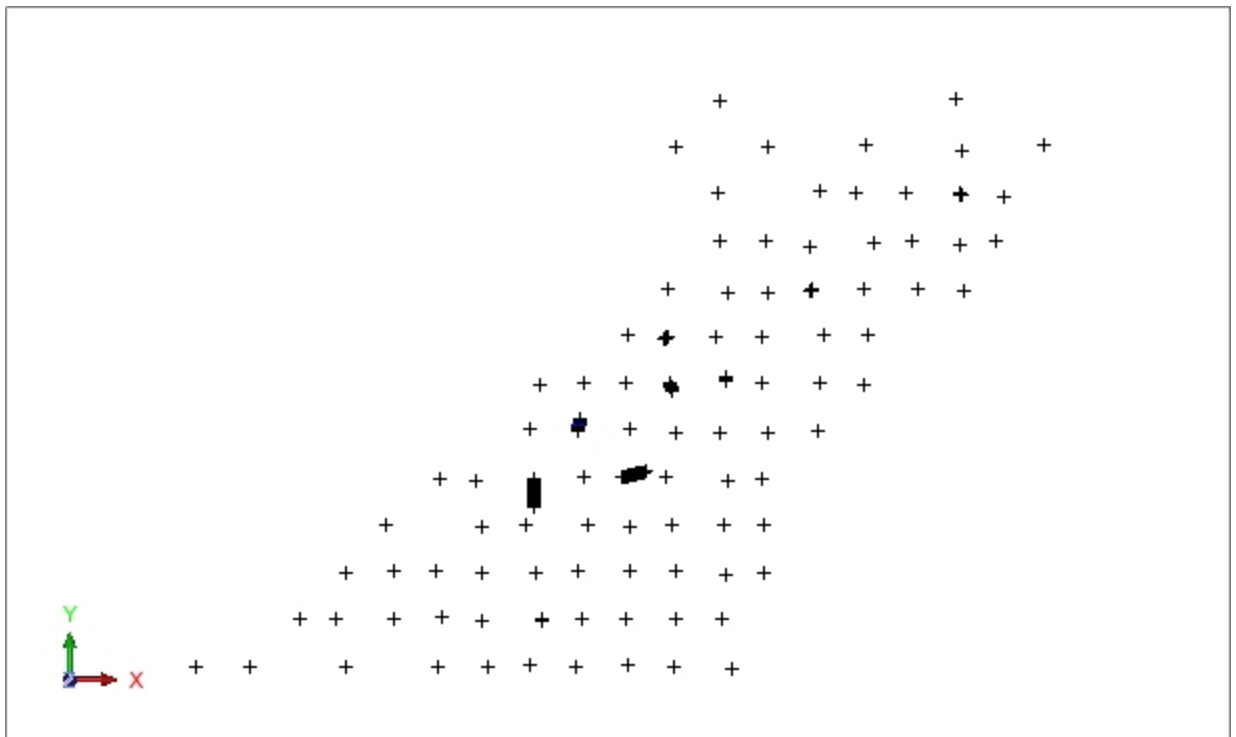

10. Choose **Display > 3D Grid**.
11. Enter the information as shown, and click **Apply**.

X
Draw a Grid

Grid Parameters

	Grid Line Interval	Label Frequency
Y Direction:	<input style="width: 90%;" type="text" value="50.000"/>	<input style="width: 90%;" type="text" value="1"/>
X Direction:	<input style="width: 90%;" type="text" value="50.000"/>	<input style="width: 90%;" type="text" value="1"/>
Z Direction:	<input style="width: 90%;" type="text" value="50.000"/>	<input style="width: 90%;" type="text" value="1"/>

Grid Planes

XY Plan	<input style="width: 60%;" type="text" value="Below"/>
XZ Section	<input style="width: 60%;" type="text" value="Behind"/>
YZ Long Section	<input style="width: 60%;" type="text" value="None"/>

?
✔ Apply
✘ Cancel

12. Zoom in and rotate the data to display the composites.

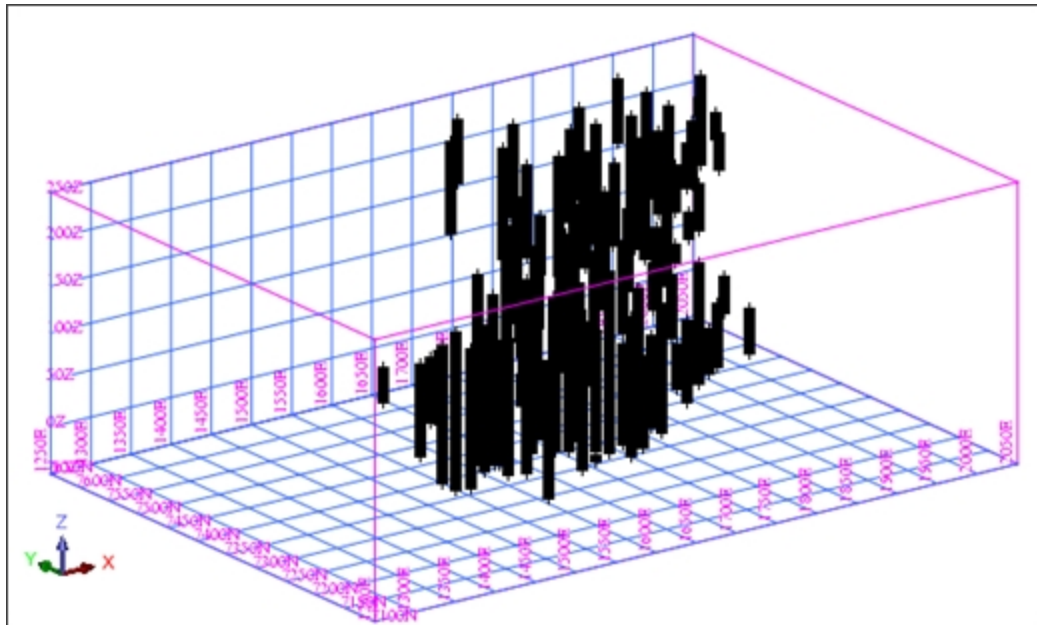

 **Note:** To see all of the steps in this task, run **06b_composite_downhole.tcl**. You need to **Apply** any forms presented.

Compositing downhole constrained by intercept table

Task: Perform composite downhole constrained by intercept table

1. Choose **Composite > Downhole**.
2. Enter the information as shown, and click **Apply**.

Composite downhole

Define the string file to create

Location

ID number

String

Composite length

Determine composite length by

Minimum % of sample to be included

Define the zone selection method

NO SELECTION

MULTIPLE ZONES

ZONE FROM TO

Dilute negative samples

Table name

Fields to be composited

	Field Name
1	<input type="text"/>

Optional weighting fields

	Field Name	Default	Include Limit
1	<input type="text"/>	1	<input type="text"/>

3. Enter the information as shown, and click **Apply**.

Define the geology zones

	TABLE	FIELD	SPECIFICATION
1	geology	lithology	QV1

Intercept from Intercept to

This is where you use the flagged intercepts created and stored in the **intersect** table. Surpac composites the samples that fall inside the intervals stored in this table.

4. Enter the information as shown, and click **Apply**.

Table Name	collar		
	Field Name	Operand	Constraint Value
1	[Dropdown]	=	[Empty]

5. Click **Reset graphics** .
6. Open **comp1.str** in **Graphics**.
7. Choose **Display > Hide everything**.
8. Choose **Display > Point > Markers**.
9. Enter the information as shown, and click **Apply**.

Drawing

Draw Markers

Layer name: comp1.str

String range: [Empty]

Seg range: [Empty]

Seg pnt range: [Empty]

Desc field number: d1

Text Alignment: <

Position of text in segment: All points First point Centroid

10. Choose **Display > 3D Grid**.

11. Enter the information as shown, and click **Apply**.

X

Draw a Grid

Grid Parameters

	Grid Line Interval	Label Frequency
Y Direction:	<input type="text" value="50.000"/>	<input type="text" value="1"/>
X Direction:	<input type="text" value="50.000"/>	<input type="text" value="1"/>
Z Direction:	<input type="text" value="50.000"/>	<input type="text" value="1"/>

Grid Planes

XY Plan	<input type="text" value="Below"/>
XZ Section	<input type="text" value="Behind"/>
YZ Long Section	<input type="text" value="None"/>

?

The composites are displayed.

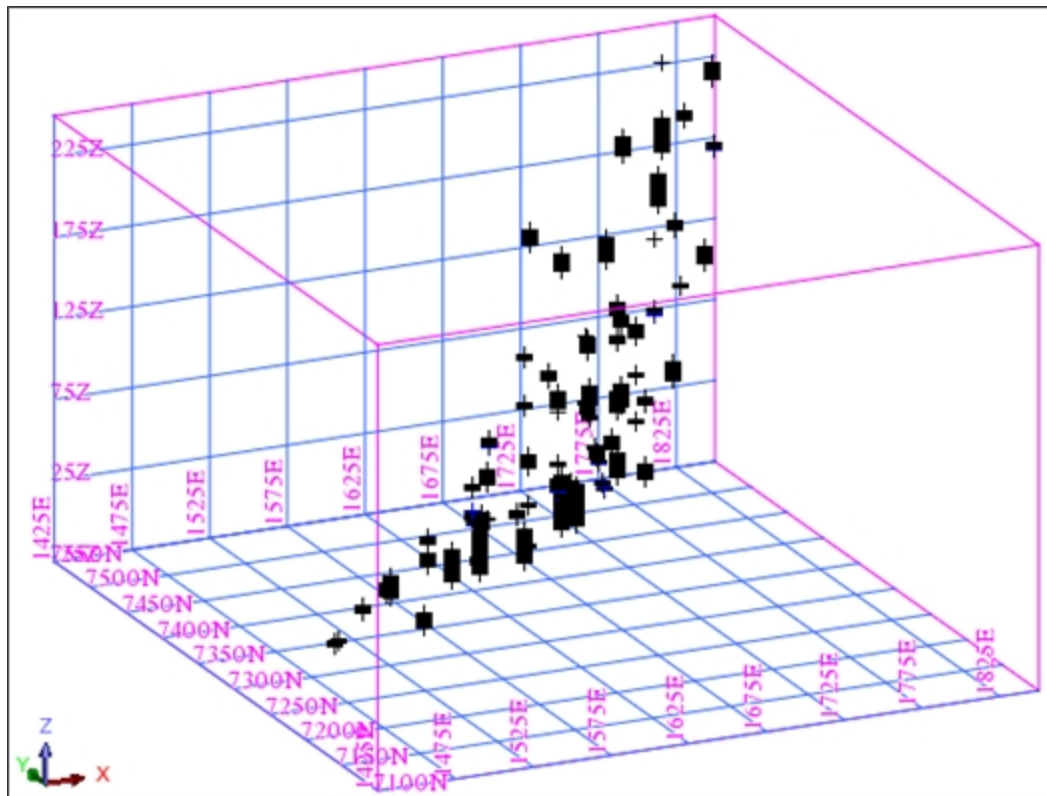

The display shows 1m composite string files inside the 3DM. String 2 contains the composites which did not meet the 75% criteria.

Note: To see all of the steps in this task, run **06c_composite_downhole_constrained_by_intercept.tcl**. You need to click **Apply** on any forms presented.

Compositing graphical

Task: Perform composite graphical

1. Click **Reset graphics** .
2. Choose **Display > Drillholes**.
3. Enter the information as shown, and click **Apply**.

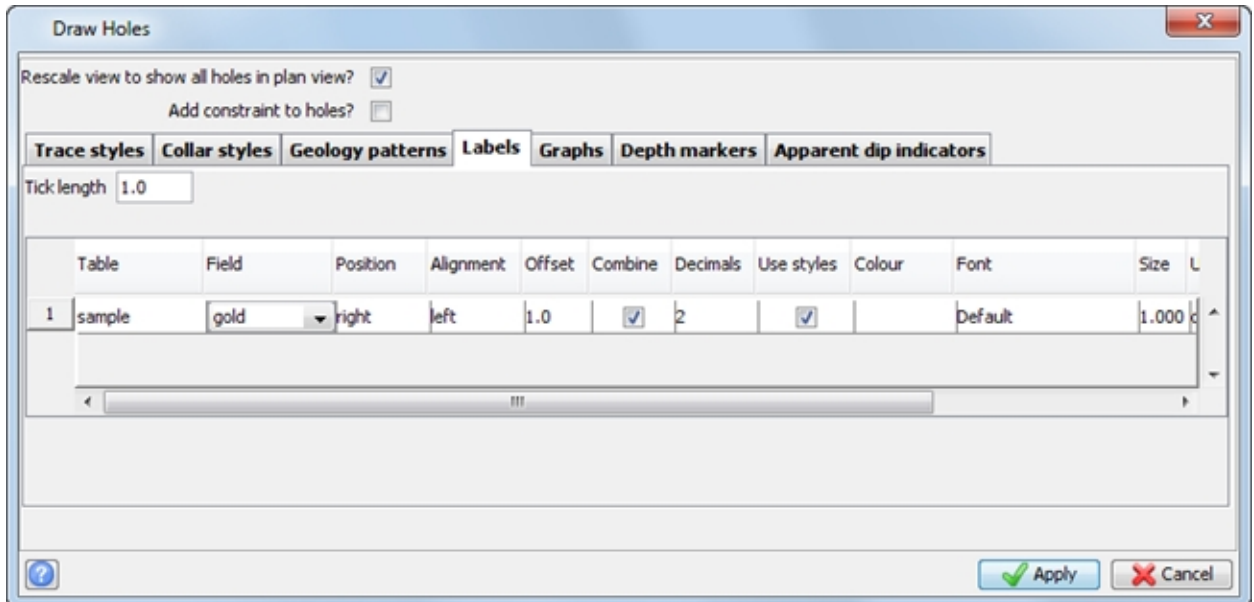

Draw Holes

Rescale view to show all holes in plan view?

Add constraint to holes?

Trace styles **Collar styles** **Geology patterns** **Labels** **Graphs** **Depth markers** **Apparent dip indicators**

Tick length 1.0

Table	Field	Position	Alignment	Offset	Combine	Decimals	Use styles	Colour	Font	Size
1	sample	gold	right	left	1.0	<input checked="" type="checkbox"/>	2	<input checked="" type="checkbox"/>	Default	1.000

4. Choose **Sections > Define**.
5. Enter the information as shown, and click **Apply**.

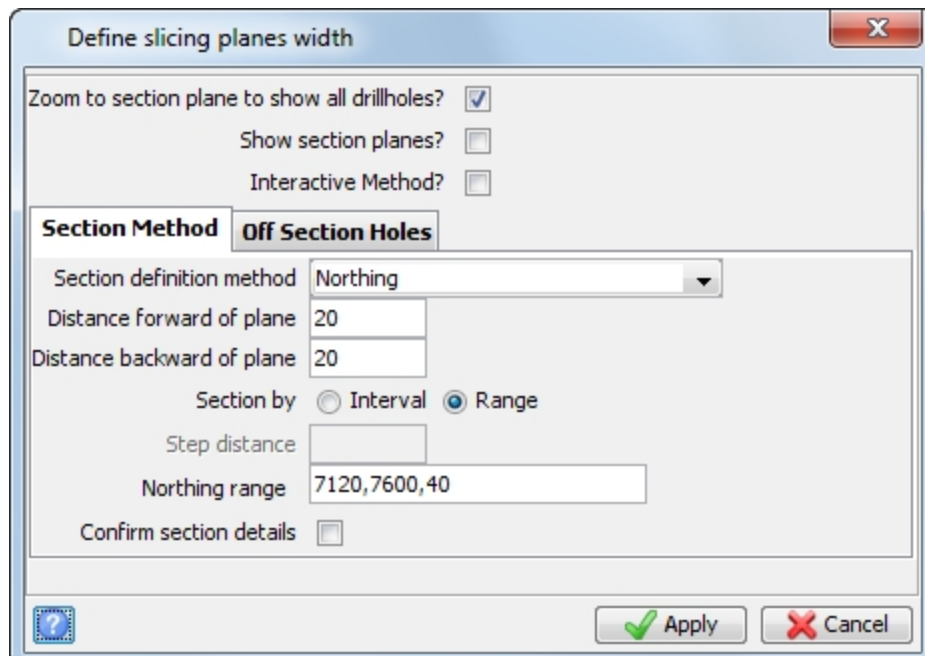

Define slicing planes width

Zoom to section plane to show all drillholes?

Show section planes?

Interactive Method?

Section Method **Off Section Holes**

Section definition method Northing

Distance forward of plane 20

Distance backward of plane 20

Section by Interval Range

Step distance

Northing range 7120,7600,40

Confirm section details

6. Zoom in on an area of high grade.
7. Choose **Composite > Setup options**.

8. Enter the information as shown.

The screenshot shows the 'Compositing Options' dialog box with the 'Composite fields' tab selected. The 'Composite colours' section has 'Composite table' and 'Composite field' dropdown menus. The 'Composite fields' table is as follows:

	Table	Field	Dilute	Label position	alignment	offset	decimals
1	sample	gold	<input checked="" type="checkbox"/>	right	left	5	2

Buttons for 'Apply' and 'Cancel' are visible at the bottom right.

Note: If you select the **Dilute** check box, negative values or missing samples are treated as zero and will dilute any composite you create. If you do not select this check box, negative values or missing samples are ignored and will not affect the composite.

9. Click the **Display options** tab and enter the information as shown.

The screenshot shows the 'Compositing Options' dialog box with the 'Display options' tab selected. The 'Display options' section includes:

- Minimum mining width: 2
- Extend smaller composites: uphole
- Marker symbol: <*>
- Size: 0.5
- Line pattern: ---
- Default line thickness: 2
- Default colour: blue

The 'Composite field display options' table is as follows:

	Table	Field	Cutoff level	type	Highlight	Use styles	Label colour	Font name	size	units
1	sample	gold				<input checked="" type="checkbox"/>		Default	1.0	oru

Buttons for 'Apply' and 'Cancel' are visible at the bottom right.

This displays the averaged sample value 1 unit high, as a thick blue trace terminated at each end by diamond shaped markers.

10. Click the **Composite code labels** tab and enter the information as shown.

The screenshot shows the 'Compositing Options' dialog box with the 'Composite code labels' tab selected. The 'Display code labels' checkbox is checked. The 'Position' dropdown is set to 'left', 'Alignment' to 'right', 'Offset' to '3', and 'Decimals' is empty. The 'Use styles' checkbox is checked, 'Colour' is empty, 'Font name' is 'Default', 'Font size' is '1', and 'Font units' is 'oru'. The 'Apply' and 'Cancel' buttons are visible at the bottom right.

This displays the code labels on the left-hand side of the drillhole trace, one unit high. The code labels are character values that represent an interval; they can be stored in a database table.

11. Click the **Thickness options** tab, enter the information as shown, and then click **Apply**.

The screenshot shows the 'Compositing Options' dialog box with the 'Thickness options' tab selected. The 'Display thickness labels' checkbox is unchecked, and the 'Use true thickness calculations' checkbox is also unchecked. The 'Apply' and 'Cancel' buttons are visible at the bottom right.

Clearing these options prevents the thickness of the composite displaying in **Graphics**.

12. Choose **Composite > Create**.

The screenshot shows the 'Specify code of interest' dialog box. The 'Code' field contains the text 'Hg_ore'. The 'Apply' and 'Cancel' buttons are visible at the bottom right.

13. Click the first composite point.
 14. Click the second composite point.
 15. Click ESC.
- A result similar to the following is displayed.

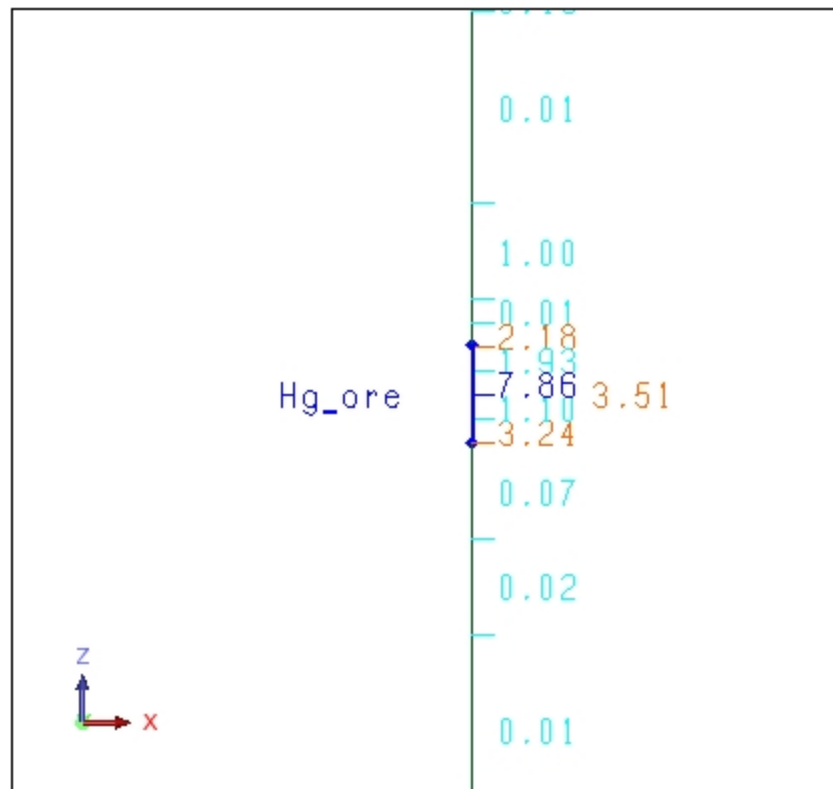

16. Choose **Composite > Setup options**.
17. Enter the information as shown, and click **Apply**.

Compositing Options

Composite fields Display options Composite code labels Optional weighting fields Thickness options

Composite colours

Composite table

Composite field

Composite fields

	Table	Field	Dilute	Label position	alignment	offset	decimals
1	sample	gold	<input checked="" type="checkbox"/>	right	right	5	2

Next, you will view the calculated grade and the exact depth_to and depth_from.

18. Choose **Composite > Edit**.
19. Click the composite.

A form similar to the following is displayed.

Composite values	
Name	Value
1	sample / gold
	3.514345579

Note: You can also edit the depths to recalculate the composite.

20. Click **Cancel**.

Creating a composite report

Task: Create a composite report

Using the previously created high-grade area you will generate a simple report for the section.

1. Choose **Composite > Report**.
2. Enter the information as shown, and click **Apply**.

The screenshot shows a dialog box titled "Create Composite Report". It contains the following fields and controls:

- Report File Name:** A text box containing "composite_report".
- Report File Format:** A dropdown menu showing ".not - Surpac Note File".
- Group By Composite Code:** A checked checkbox.
- Buttons:** A help icon (question mark in a blue square), an "Apply" button with a green checkmark, and a "Cancel" button with a red X.

Note: Selecting the **Group by Composite code** check box groups all the Hg_ore code composites together.

Composite Report				
Hg_ore	hole Id	depth From	depth To	Sample
gold				
(diluted)				

WRC045	17.940	21.972	3.51	
Composite Report				

Domains

One of the most important aspects of geostatistics is to ensure that any data set is correctly classified into a set of homogenous "domains". A domain is either a 2D or 3D region within which all data is related. Mixing data from more than one domain or not classifying data into correct domains can often be the source of estimation errors.

A simple example

Imagine that you are a meteorologist, and you are given three air temperatures measured at locations A, B, and C, as displayed below. Based on the values shown, what would you guess the temperature is at location X? Would you guess that the temperature at location X was greater than 25?

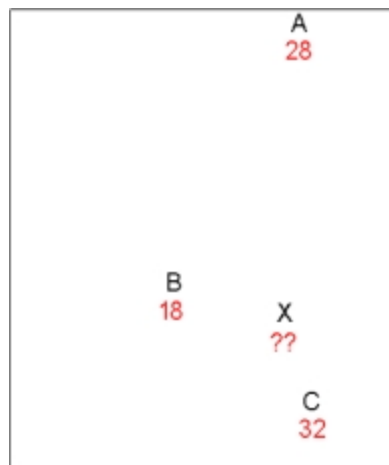

Using the information above, you may have the following thoughts:

1. Because location A is relatively distant from X, the value at A may have little or no influence on the estimated temperature at X.
2. Because locations B and C are about the same distance from X, they will probably have equal influence on the estimated temperature.
3. Given the previous two points, the temperature at X would probably be the average of the temperatures at B and C: $(18 + 32) / 2 = 25$ degrees
4. Because the influence of A has not been accounted for at all, and the estimate is exactly 25 degrees, it is difficult to say with certainty if the temperature at X is above 25 degrees.

Now consider the following. Imagine that you want to go to your favourite beach, but only if the temperature is 25 degrees or more. You have three friends who live near the beach you want to go to, and you call them up and ask each one what the temperature is at each of their homes. You draw the map below, with the locations of each friend (A, B, and C) and the temperatures they give you. Your favourite beach is at location X. Note that the friend at location B lives high up in the mountains, while friends at A and C live near the beach.

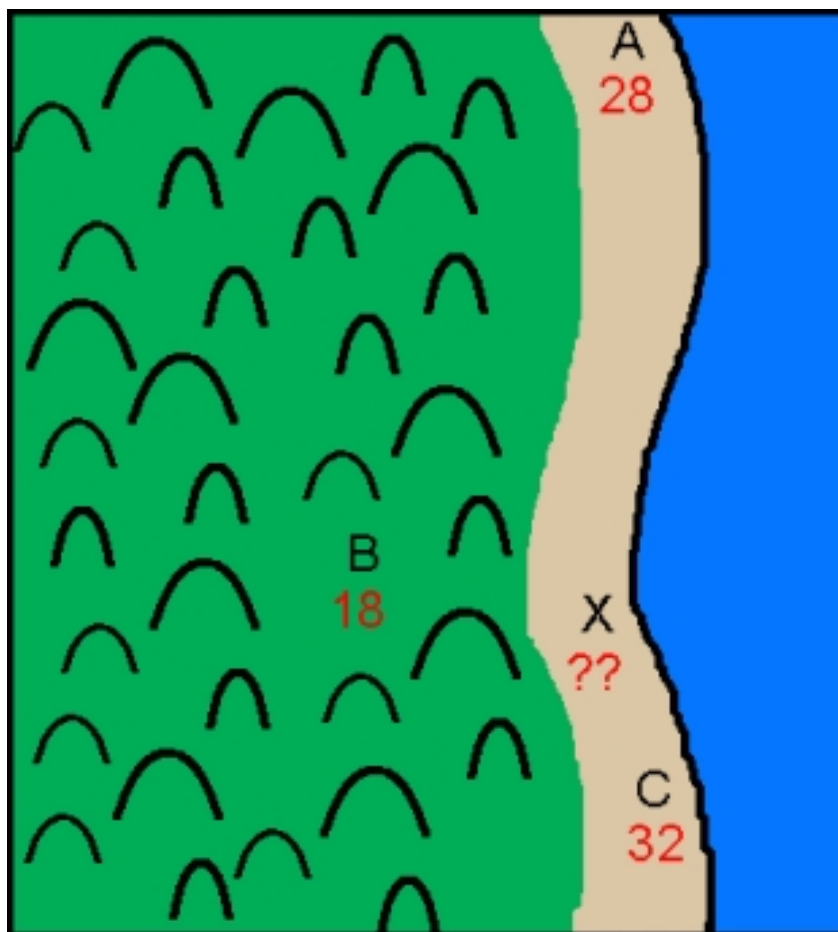

Using the information above, you may have the following thoughts:

1. The data from B can be ignored, because temperatures high up in the mountains are usually not good estimates of temperatures on the beach.
2. A and C are on the beach, so they can be used to guess the temperature at X.
3. Because X is between A and C on the map, the temperature at X will probably be somewhere between the temperature at A and the temperature at C.
4. Therefore, the temperature at X will be somewhere between 28 and 32 degrees
5. Because the temperature range of 28 to 32 degrees is greater than the minimum value of 25 degrees, you would probably decide "Yes, I'm going to the beach!"

Compare this example with the first one. In both cases, all of the locations and temperatures are exactly the same. However, in the second case, when you took account of the domain which contains the data, you came up with a considerably different result. The point is that separating data into similar regions, or domains, is a very important part of making any geostatistical estimation.

Viewing domains in Surpac

Task: View domains in Surpac

1. Open **all_composites2.str**.
2. Choose **Display > Hide everything**.
3. Choose **Display > Point > Markers**.

- Enter the information as shown, and click **Apply**.

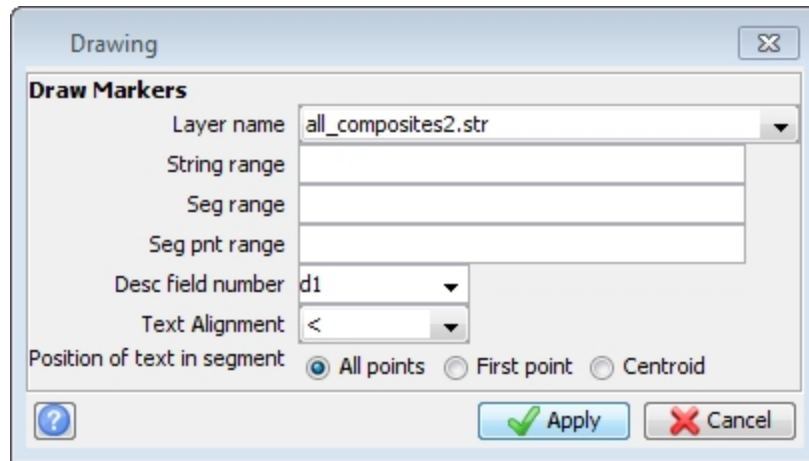

- Choose **Display > 3D grid**.
- Enter the information as shown, and click **Apply**.

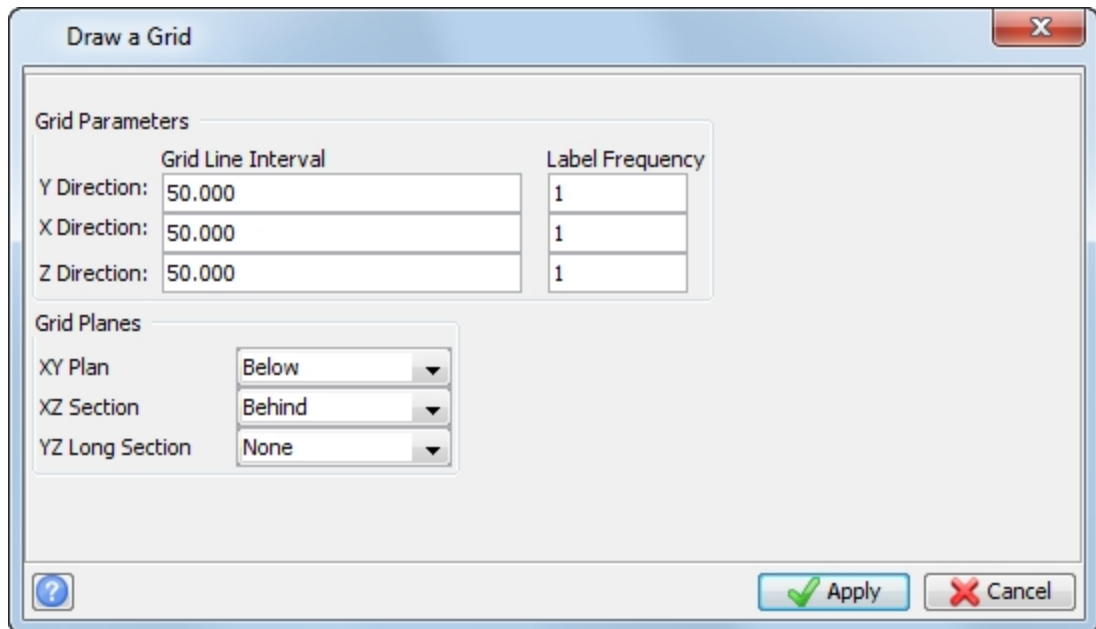

- Use the left mouse button to rotate the view.
The composites are displayed. The points in this string file represent 2 metre downhole composites. The D1 field contains the composited value for gold. The D1 values have been used to classify the points into different strings.

String	D1
1	< 1.000
2	1 – 1.999
3	2 – 2.999
4	3 – 3.999
5	4 – 4.999
6	5 – 5.999
7	>= 6.000

As in the first example, any estimation that you would make with only this file would be based only on the distances between the sample points and the estimated location.

- With **all_composites2.str** displayed, open **ore1.dtm**.

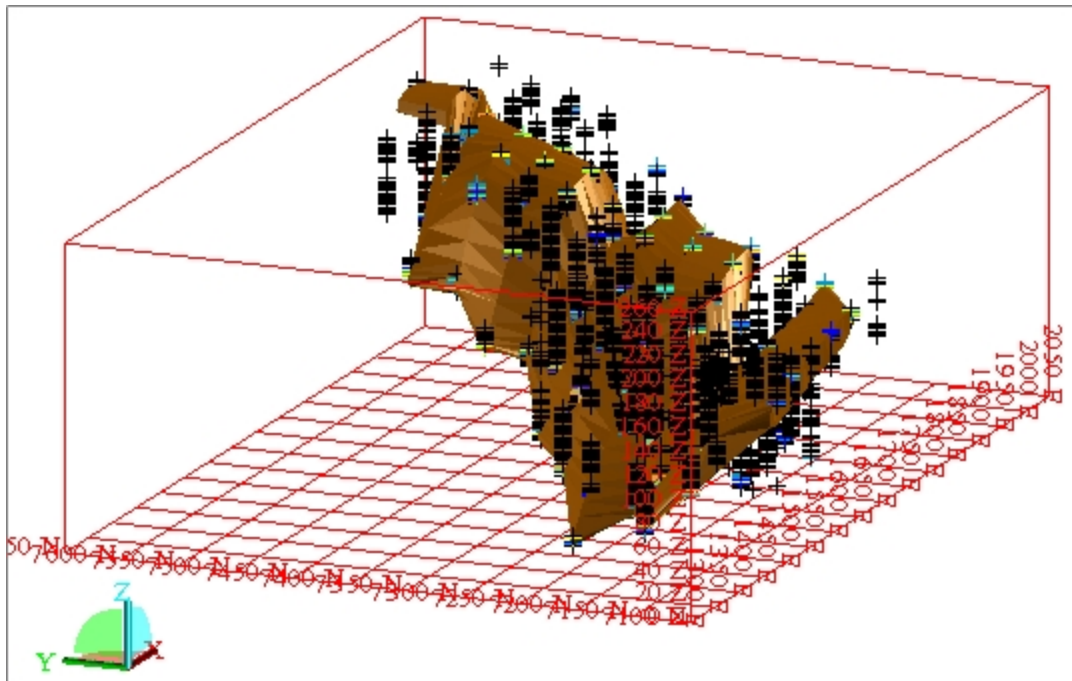

This solid represents a single domain, as interpreted by a geologist. Only composites which are inside this domain should be used to estimate points inside the domain.

Extracting data with a domain in Surpac

Task: Extract data with a domain in Surpac

The domain **ore1.dtm** represents an ore zone known as the QV1 zone. You will now go through the process of extracting composites only inside the QV1 domain.

1. Run the macro **07_create_downhole_composites.tcl**.
2. After reading the text below on the first form, click **Apply**.

A geostatistical analysis of data in a drillhole database generally starts with compositing a sample value within a given geological zone.

In this example, we will be creating 2 meter downhole composites within the QV1 geological code.

To run the function **COMPOSITE DOWNHOLE** you use **Composite > Downhole**.

3. Enter the information as shown, and click **Apply**.

On the next form, the character field **lithology** exists in the **geology** table, which is an interval table. The text "QV1" has been inserted into the field **lithology** for every interval of a drillhole which is inside **ore1.dtm**.

4. After viewing the form, click **Apply**.

	TABLE	FIELD	SPECIFICATION
1	geology	lithology	QV1

Intercept from 1 Intercept to 999

5. After reading the text on the next form, click **Apply**.

2 meter downhole composites have been created within the QV1 rock type, and are stored in the D1 field `ingold_comp2.str`.

String 1 contains composites where 50% to 100% of the 2m length contained a gold value.

String 2 contains composites where less than 50% of the 2m length contained a gold value.

Either or both of these strings may be used for further geostatistical analysis. In this example, you will use both strings.

An east-west section of the database, and the composites which were created, are displayed.

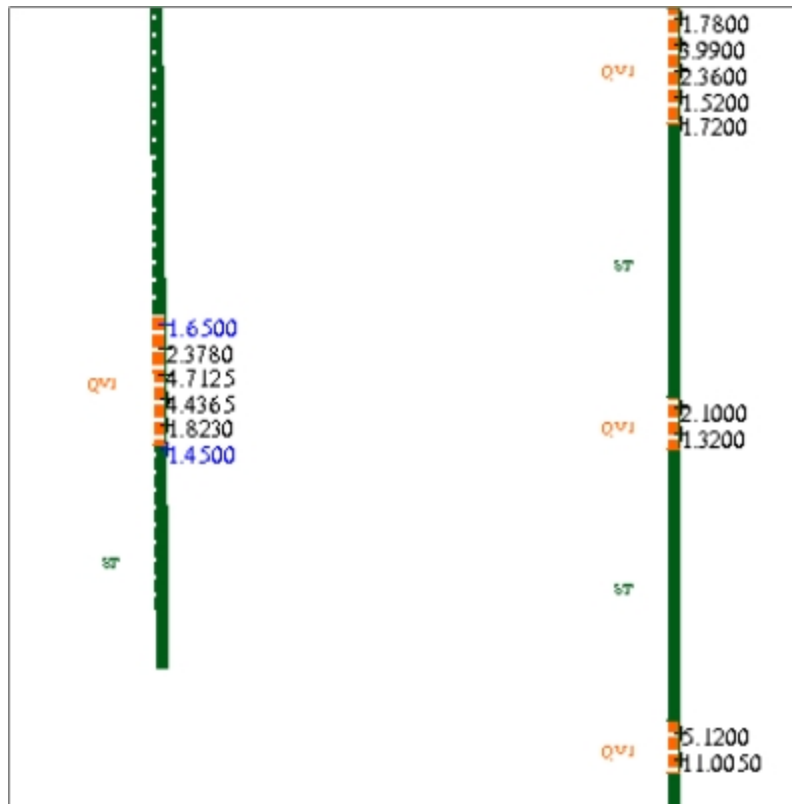

Basic Statistics

The Histogram

A histogram is a statistical term which refers to a graph of frequency vs. value. A histogram is the graphical version of a table which shows what proportion of cases fall into each of several non-overlapping intervals of some variable.

For example, you could represent a distribution of gold grades with the following table:

Gold (g/t)	Number of samples (frequency)
0.0 - 0.5	0
0.5 - 1.0	40
1.0 - 1.5	58
1.5 - 2.0	82
2.0 - 2.5	40
2.5 - 3.0	29
3.0 - 3.5	18
3.5 - 4.0	10
4.0 - 4.5	12
4.5 - 5.0	5
5.5 - 6.0	5
6.0 - 6.5	5
6.5 - 7.0	5
7.0 - 7.5	8
7.5 - 8.0	5

You can display this same data in a histogram as shown:

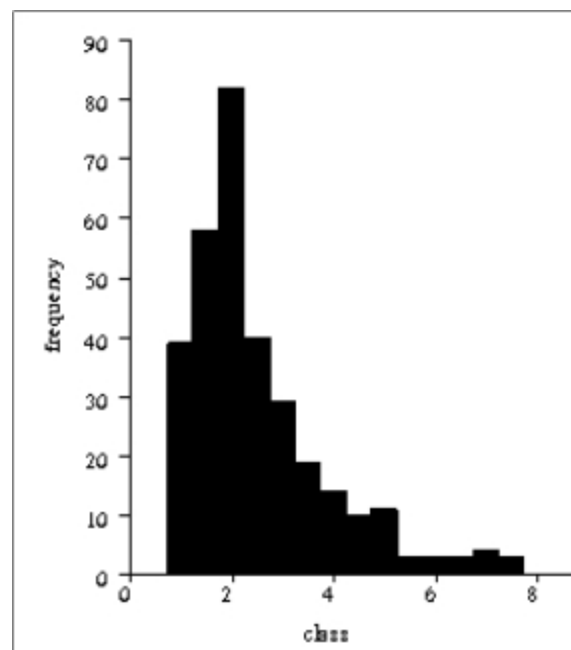

Bimodal Distributions

The "mode" is the most commonly occurring value in a data set. For example, in the following data set, the number 8 is the mode:

1 3 5 5 8 8 8 9

"Bimodal" means that there are two relatively "most common" values which are not adjacent to one another. In the following data set, the numbers 2 and 8 are equally common, and the distribution is said to be "bimodal":

1 2 2 2 3 5 5 8 8 8 9

Imagine that you are studying the average specific gravity, or density of rocks in a coal deposit. A histogram of all rock samples might look like this:

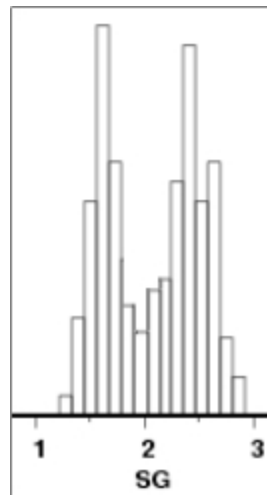

Any histogram which displays two peaks, as in the previous example, is said to be "bimodal". You can explain the bimodal distribution in the previous example by the fact that the data set is comprised of coal samples as well as intervening sandstone and mudstone bands. The specific gravity values between 1 and 2 are representative of the coal, while specific gravity values between 2 and 3 represent the intervening rock.

Often the source of a bimodal distribution can be two domains being mixed into a single data set. In order to minimise estimation errors, you should make every attempt to separate any data set which has a bimodal distribution. In the example above, merely segregating the data based on rock type would result in two separate normal distributions.

Outliers

An "outlier" is a statistical term for a value that is significantly different than the majority of all other values in the data set. For example, in the following data set, the number 236 would be considered to be an outlier:

1 3 5 5 8 8 8 236

Outliers can cause "noisy" experimental variograms, which are difficult to model. Additionally, if you use outliers in an estimation, they can cause unrealistic results. One technique to reduce the effect of outliers is to apply a "cutoff", or "topcut" to them. In the previous example, the value of 236 could be "cut", or changed to a value of 9:

1 3 5 5 8 8 8 9

Another alternative is to remove the outlier values.

Displaying Histograms in Surpac

Task: Display Histogram

1. Run the macro **08a_basic_statistics.tcl**.
2. After reading the text below on the first form, click **Apply**.

Basic statistics should be performed before variogram modelling for a couple of reasons:

1. The shape of the histogram can be used to determine if a distribution is bimodal (has two humps).
If the histogram shows a bimodal distribution, the data should be analysed graphically to see if it can be physically segregated into two separate zones. If so, each zone should be modelled separately.
2. The quality of experimental variograms and subsequent block model estimations are sensitive to outliers (relatively large values).

Outlier values should be cut or removed prior to variogram modelling or block model estimation. The value used to cut or remove outliers can be calculated from information in the basic statistics report.

The macro runs **Analysis > Basic statistics window** to open the **Basic Statistics** window.

The macro then runs **File > Load data from string files**.

The following form is displayed.

Basic statistics

Basic **Advanced**

Location gold_comp

Id range 2

String range 1,2

Description Fields for Data

	D Field	Name	Minimum value	Maximum value
1	D1	Gold		

Histogram Bins

Number 20

Width 1

Include Coordinate Graphs?

Basic Statistics on gold_comp2.str

You will use strings 1 and 2 from the file **gold_comp2.str** as the basis of your study. The columns labelled "Minimum value" and "Maximum value" allow you to exclude data which is below a given minimum value or above a given maximum value.

On the **Advanced** tab, you can exclude data which is greater or less than any Y, X, or Z coordinate values.

The D1 field contains values of gold in grams per tonne. The **Name** field is optional. The name value will appear on the output report.

Also, note that it is possible to view the histogram based on a number of bins or on a bin width. The "**bin width**" method is more commonly used.

3. After reviewing the form, click **Apply**.

Next, a histogram and a line representing the cumulative frequency is displayed. The cumulative frequency is an accumulation of the values of all previous histogram bins.

The macro then runs **Statistics > Report**. This form prompts you to enter the name of an output report, the report format, and a range of percentiles which will be written to the report.

4. When you have finished viewing the form, click **Apply**.

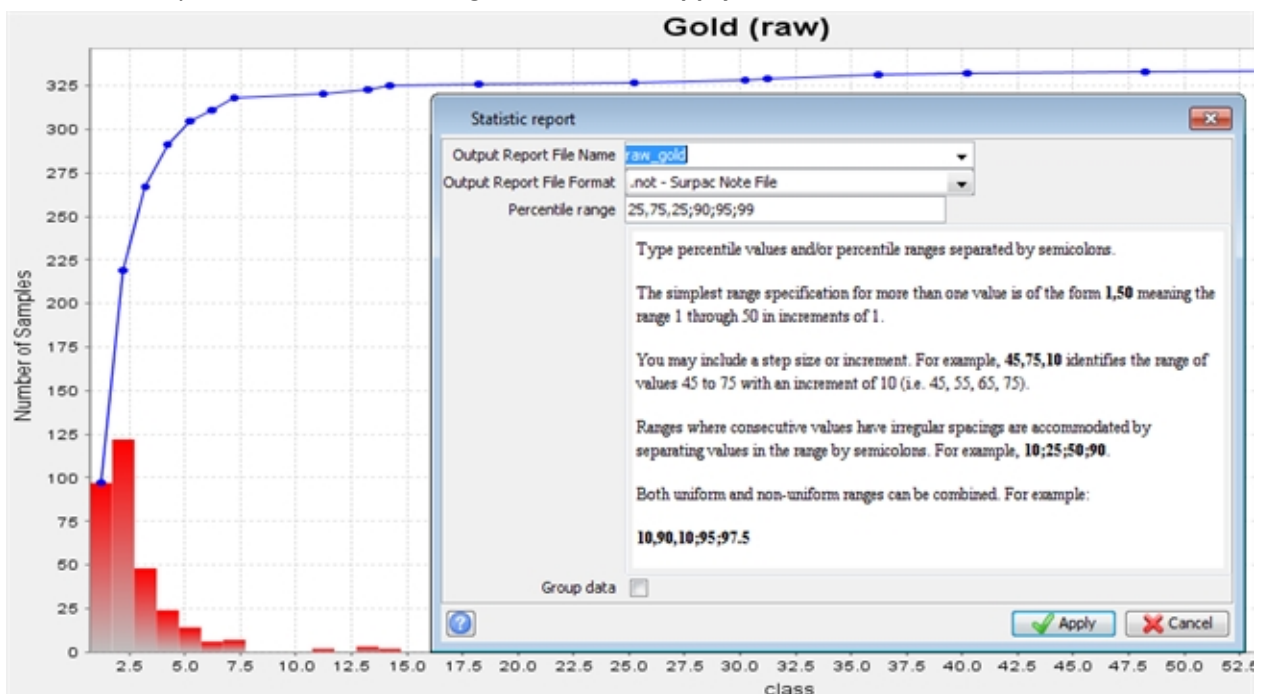

Basic statistics histogram and report

5. After reading the text displayed on the next form, click **Apply**.

As you can see from the histogram, this distribution is not bimodal.

The basic statistics report will be displayed next.

Note the values of the mean, standard deviation, and percentiles.

The output report **raw_gold.not** is displayed.

Output Filename: raw_gold		Statistics Report		Apr 12, 2012						
File	Gold Comp2.str									
String range	1,2									
Variable	Gold									
Number of samples	335									
Minimum value	0.730000									
Maximum value	63.490000									
Ungrouped Data										
Mean	3.828476									
Median	2.120000									
Geometric Mean	2.533744									
Variance	46.672186									
Standard Deviation	6.831704									
Coefficient of variation	1.784445									
Moment 1 About Arithmetic Mean	0.000000									
Moment 2 About Arithmetic Mean	46.672186									
Moment 3 About Arithmetic Mean	1870.710266									
Moment 4 About Arithmetic Mean	90362.538844									
Skewness	5.867044									
Kurtosis	41.483189									
Natural Log Mean	0.929698									
Log Variance	0.500146									
25.0 Percentile	1.657500									
50.0 Percentile (median)	2.120000									
75.0 Percentile	3.297850									
90.0 Percentile	5.120000									
95.0 Percentile	9.280000									
99.0 Percentile	44.112500									
Trimean	2.298838									
Biweight	2.234705									
MAD	0.704705									
Alpha	-0.729756									
Sichel-t	3.250600									
Normal Histogram Tabulation										
Gold										
Class From	Class To	Count	Mean	Freq %	Cum Count	Cum Mean	Cum Freq %	Dec Count	Dec Mean	Dec Freq %
0.730000	1.730000	97	1.358301	0.290	97	1.358301	28.9552	335	3.828476	100.0000
1.730000	2.730000	122	2.155034	0.364	219	1.802143	65.3731	238	4.835227	71.0448
2.730000	3.730000	48	3.166762	0.143	267	2.047468	79.7015	116	7.654051	34.6269
3.730000	4.730000	24	4.194958	0.072	291	2.224581	86.8657	68	10.821549	20.2985
4.730000	5.730000	14	5.094464	0.042	305	2.356313	91.0448	44	14.436052	13.1343
5.730000	6.730000	6	6.167500	0.018	311	2.429841	92.8358	30	18.795460	8.9552
6.730000	7.730000	7	7.198400	0.021	318	2.534809	94.9254	24	21.952450	7.1642
10.730000	11.730000	2	11.095000	0.006	320	2.588310	95.5224	17	28.027647	5.0746
12.730000	13.730000	3	13.040000	0.009	323	2.685385	96.4179	15	30.285333	4.4776
13.730000	14.730000	2	14.252500	0.006	325	2.756567	97.0149	12	34.596667	3.5821
17.730000	18.730000	1	18.435000	0.003	326	2.804660	97.3134	10	38.665500	2.9851
24.730000	25.730000	1	25.390000	0.003	327	2.873729	97.6119	9	40.913333	2.6866
29.730000	30.730000	1	30.355000	0.003	328	2.957513	97.9104	8	42.853750	2.3881
30.730000	31.730000	1	30.750000	0.003	329	3.041989	98.2090	7	44.639286	2.0896
35.730000	36.730000	2	36.060000	0.006	331	3.241493	98.8060	6	46.954167	1.7910
39.730000	40.730000	1	40.225000	0.003	332	3.352889	99.1045	4	52.401250	1.1940
47.730000	48.730000	1	48.000000	0.003	333	3.486965	99.4030	3	56.460000	0.8955
57.730000	58.730000	1	57.890000	0.003	334	3.649848	99.7015	2	60.690000	0.5970
62.730000	63.730000	1	63.490000	0.003	335	3.828476	100.0000	1	63.490000	0.2985
1/1										

Removing Outliers in Surpac

Task: Remove Outliers

Looking back to the histogram of **gold_comp2.str**, as well as the output report, you can see that the majority of the data is grouped between values of 0 and 10 grams per tonne. Also, you can see that there are several outlier values above 10 grams per tonne.

1. Run the macro **08b_cut_outliers.tcl**.
2. After reading the text below on the first form, click **Apply**.

Variograms and subsequent block model estimations are sensitive to outliers (relatively large values). One method of dealing with these data is to reduce, or 'cut' them to some lesser value. The value used to cut outliers can be determined by one of several methods, including:

1. The upper limit of a given confidence interval
2. A given percentile
3. An arbitrarily chosen value

In this example, you will use the value which defines the upper limit of a 95% confidence interval

A confidence interval is an estimated range of values which is likely to include a given percentage of the data values. Since a confidence interval is based on the data alone, it is useful where there is little or no knowledge of the deposit. The calculation for the upper limit of a 95% confidence interval (CI) is:

$$95\% \text{ CI} = \text{mean} + (1.96 * \text{standard deviation})$$

For this data set, mean = 3.828 and standard deviation = 6.831

$$95\% \text{ CI} = 3.828 + (1.96 * 6.831)$$

$$95\% \text{ CI} = 17.217$$

For simplicity, you will use the nearest integer value of 17 to cut the outlier data.

As stated above, other methods can be used to select the outlier cutoff, such as a percentile, or an arbitrarily chosen value.

A percentile is that data value at which a given percentage of all other data values fall below. Any given percentile value could be selected as the outlier cutoff, such as the 90th, 95th, or 99th percentile. Recall the following percentile values were given in the basic statistics report:

90th Percentile: 5.120

95th Percentile: 9.280

99th Percentile: 44.112

An arbitrarily chosen value based on knowledge of the deposit and sampling methods may also be used. For example, if part of an ore zone has been mined, information from grade control samples and reconciliation studies may provide a good idea of what the maximum mined block value will be. If the deposit has not yet been mined, information from similar deposits may be useful in determining a value.

Whatever method is chosen, values in a description field in a string file can be cut with the use of STR MATHS.

You run **STR MATHS** by choosing **File tools > String maths**.

The *String Maths* form prompts you to enter the name of the input and output files, as well as an expression. Before viewing this form, the macro has opened **gold_comp2.str**, and saved it as **gold_cut17.str**.

The D1 field receives the result of the expression: `iif(d1>17,17,d1)`

You can reword this expression as:

If the initial value of d1 is greater than 17, then set the value of d1 equal to 17, else leave the value of d1 as it was initially.

3. When you have completed viewing the form, click **Apply**.

String maths ✕

Define the files to be processed

Location ▼

ID range

Define the files to be created

Location ▼

	String range	Constraint	Field	=	Expression
1			d1	=	if(d1>17,17,d1)
2				=	
3				=	
4				=	
5				=	
6				=	
7				=	
8				=	
9				=	
10				=	

? ✓ Apply ✕ Cancel

Using string maths to cut outliers

In order to validate the output from **STR MATHS**, you will analyse the data in the **Basic Statistics** window. Again, you run this by selecting **Geostatistics > Basic statistics**.

Next, the macro will choose **File > Load data from string files**, and the following form below is displayed. Notice that **gold_cut17.str** is the file being analysed.

4. When you have finished viewing the form, click **Apply**.

Basic statistics

Basic **Advanced**

Location: gold_cut

Id range: 17

String range: 1,2

Description Fields for Data

D Field	Name	Minimum value	Maximum value
1	D1	Gold	

Histogram Bins
 Number: 20
 Width: 1

Include Coordinate Graphs?

Apply Cancel

Next, a histogram and a line representing the cumulative frequency is displayed. Notice that the maximum data value is now 17. After this, the macro selected **Statistics > Report**. This form prompts you to enter the name of an output report, the report format, and a range of percentiles which will be written to the report.

5. When you have finished viewing the form, click **Apply**.

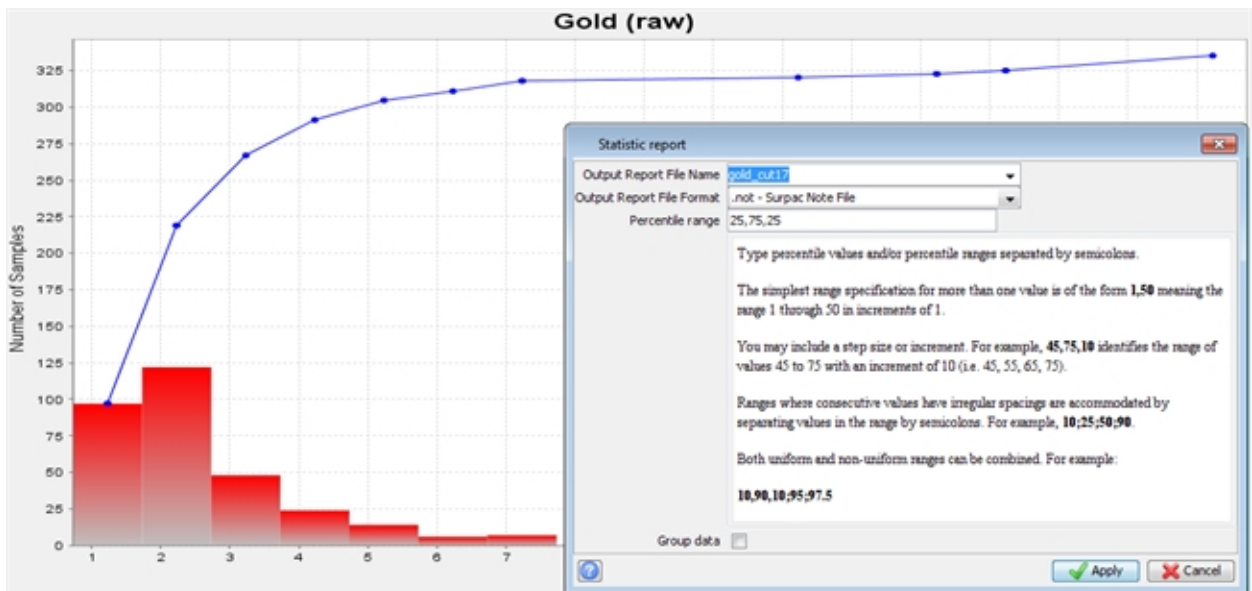

Percentile range definition

6. After reading the text below on the next form, click **Apply**.

The D1 field in the file gold_cut17.str contains the D1 values from gold_comp2.str.

As displayed by this histogram, you can see that the maximum value is 17.000.

The D1 field in gold_cut17.str will now be used for all subsequent variography analysis, as well as block model estimation.

The output report **gold_cut17.not** contains several output statistics, including the specified percentiles. This file is created in the directory, but is not displayed by the macro.

7. Open **gold_cut17.not** and verify that the maximum value is 17.

Output Filename: gold_cut17		Statistics Report		Apr 12, 2012							
File		Gold Cut17.str									
String range		1,2									
Variable		Gold									
Number of samples		335									
Minimum value		0.730000									
Maximum value		17.000000									
		Ungrouped Data									
Mean		3.181744									
Median		2.120000									
Geometric Mean		2.476903									
Variance		9.813599									
Standard Deviation		3.132666									
Coefficient of variation		0.984575									
Moment 1 About Arithmetic Mean		0.000000									
Moment 2 About Arithmetic Mean		9.813599									
Moment 3 About Arithmetic Mean		98.371421									
Moment 4 About Arithmetic Mean		1298.903259									
Skewness		3.199827									
Kurtosis		13.487150									
Natural Log Mean		0.907009									
Log Variance		0.392231									
25.0 Percentile		1.657500									
50.0 Percentile (median)		2.120000									
75.0 Percentile		3.297850									
Trimean		2.298838									
Biweight		2.234705									
MAD		0.704705									
Alpha		-0.729756									
Sichel-t		3.011461									
Normal Histogram Tabulation											
Gold											
Class From	Class To	Count	Mean	Freq %	Cum Count	Cum Mean	Cum Freq %	Dec Count	Dec Mean	Dec Freq %	
0.730000	1.730000	97	1.358301	0.290	97	1.358301	28.9552	335	3.181744	100.0000	
1.730000	2.730000	122	2.155034	0.364	219	1.802143	65.3731	238	3.924912	71.0448	
2.730000	3.730000	48	3.166762	0.143	267	2.047468	79.7015	116	5.786335	34.6269	
3.730000	4.730000	24	4.194958	0.072	291	2.224581	86.8657	68	7.635446	20.2985	
4.730000	5.730000	14	5.094464	0.042	305	2.356313	91.0448	44	9.512075	13.1343	
5.730000	6.730000	6	6.167500	0.018	311	2.429841	92.8358	30	11.573627	8.9552	
6.730000	7.730000	7	7.198400	0.021	318	2.534809	94.9254	24	12.925158	7.1642	
10.730000	11.730000	2	11.095000	0.006	320	2.588310	95.5224	17	15.283235	5.0746	
12.730000	13.730000	3	13.040000	0.009	323	2.685385	96.4179	15	15.841667	4.4776	
13.730000	14.730000	2	14.252500	0.006	325	2.756567	97.0149	12	16.542083	3.5821	
16.730000	17.730000	10	17.000000	0.030	335	3.181744	100.0000	10	17.000000	2.9851	
							1/1				